



US00D324246S

# United States Patent [19]

[11] Patent Number: **Des. 324,246**

**Ching-Tien**

[45] Date of Patent: **\*\* Feb. 25, 1992**

## [54] TOY CONVERTIBLE CAR

[76] Inventor: **Yang Ching-Tien, 70, PeiHwei, HweiGuei Village, Shoei Shang Shiang, ChiaYi Hsien, Taiwan**

[\*\*] Term: **14 Years**

[21] Appl. No.: **484,667**

[22] Filed: **Feb. 26, 1990**

[52] U.S. Cl. .... **D21/78**

[58] Field of Search ..... **D21/71, 75, 76, 78, D21/80, 81, 136, 137; D12/91, 92; 280/87.021, 87.01, 47.34, 47.371, 296, 177**

Sears Catalog 1981, p. 594, #2.  
Childcraft Catalog 1984, p. 51, "D" Toy Catalogs 84-87 Digest.

Sears Catalog 1985, p. 572, #5.  
Sears Catalog 1985, pp. 4-5, #1.  
Pines Catalog 1970, #170.  
Pines Catalog 1970, #91.  
Pines Catalog 1970, #107.

*Primary Examiner*—Bernard Ansher  
*Assistant Examiner*—R. Barkai  
*Attorney, Agent, or Firm*—Larson and Taylor

## [57] CLAIM

The ornamental design for toy convertible car, as shown and described.

## [56] References Cited

### U.S. PATENT DOCUMENTS

D. 147,423	9/1947	Smith	.....	D21/78
D. 187,994	5/1960	Schreckengost	.....	D21/78
D. 233,321	10/1974	Wilfert	.....	D12/92
D. 256,150	7/1980	Lofton et al.	.....	D21/76
D. 258,425	3/1981	Scherenberg	.....	D21/92
D. 268,659	4/1983	Reaume	.....	D12/92
D. 283,692	5/1986	Breitschwerdt	.....	D12/92

### OTHER PUBLICATIONS

Sears Catalog 1981 p. 597, #11.

## DESCRIPTION

FIG. 1 is a perspective view of a toy convertible car showing my new design;  
FIG. 2 is a top plan view thereof;  
FIG. 3 is a front elevational view thereof;  
FIG. 4 is a left side elevational view thereof;  
FIG. 5 is a right side elevational view thereof;  
FIG. 6 is a rear elevational view thereof;  
FIG. 7 is a bottom plan view thereof; and  
FIG. 8 is similar to FIG. 1 but showing the hood with a different shape.

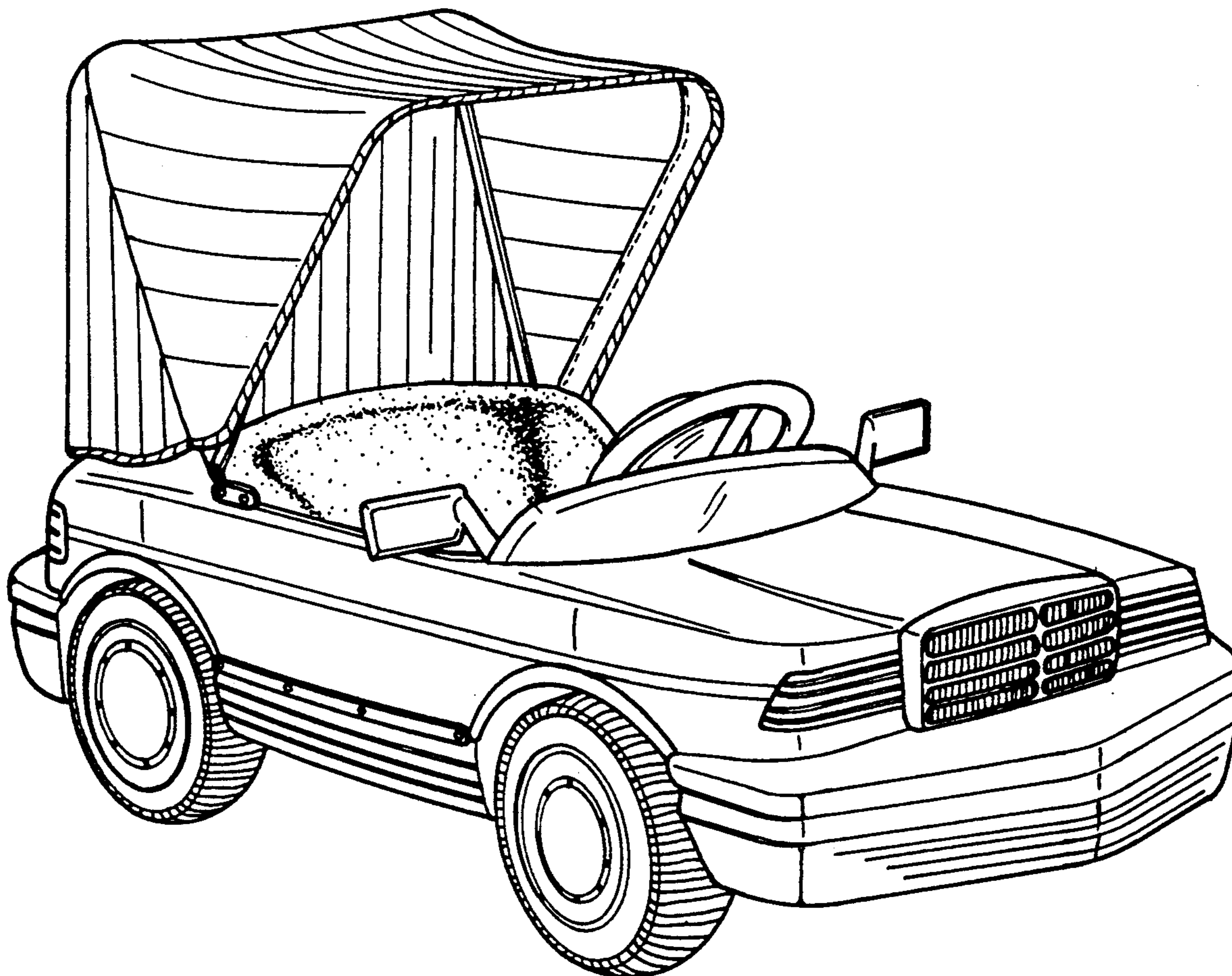

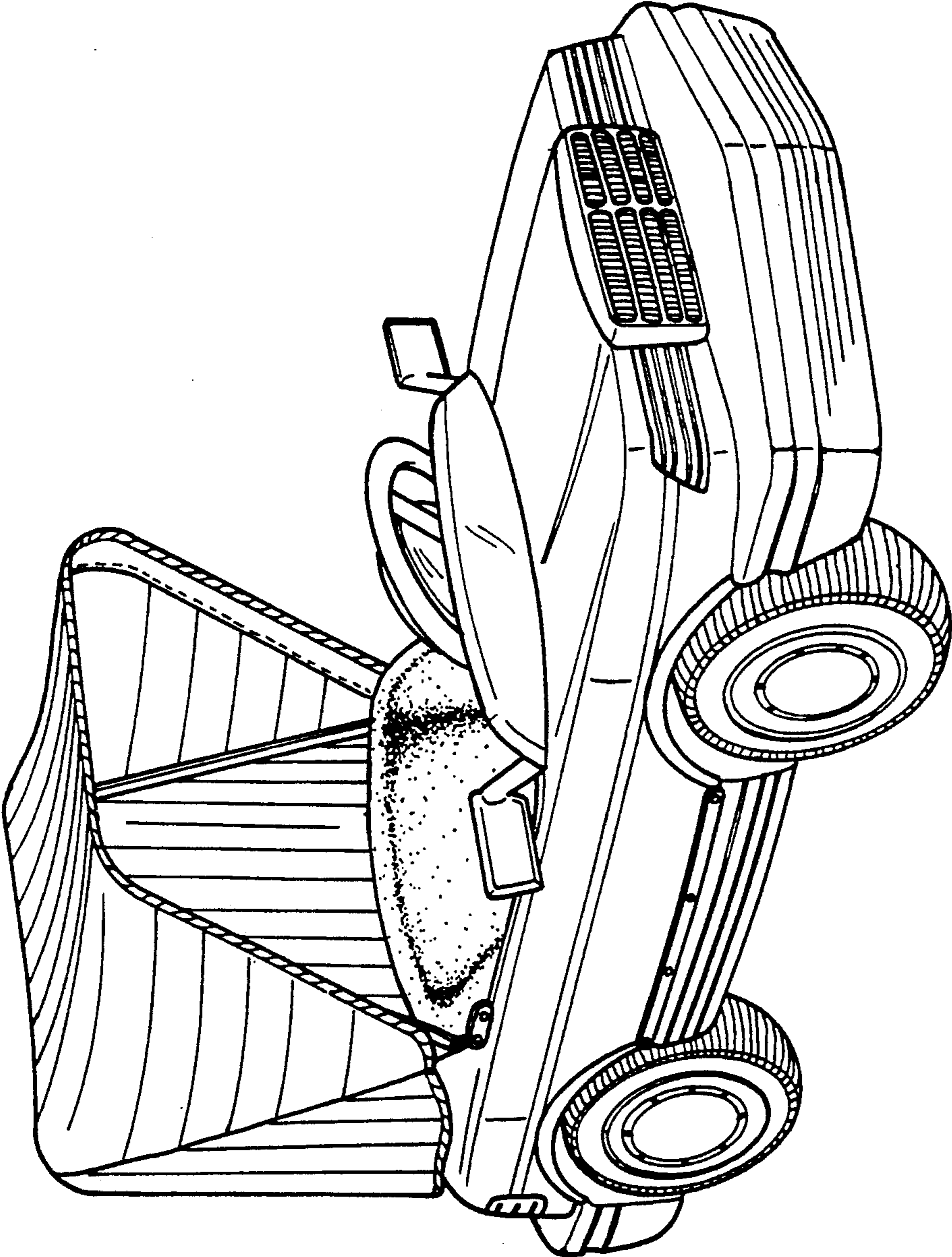

FIG. 1

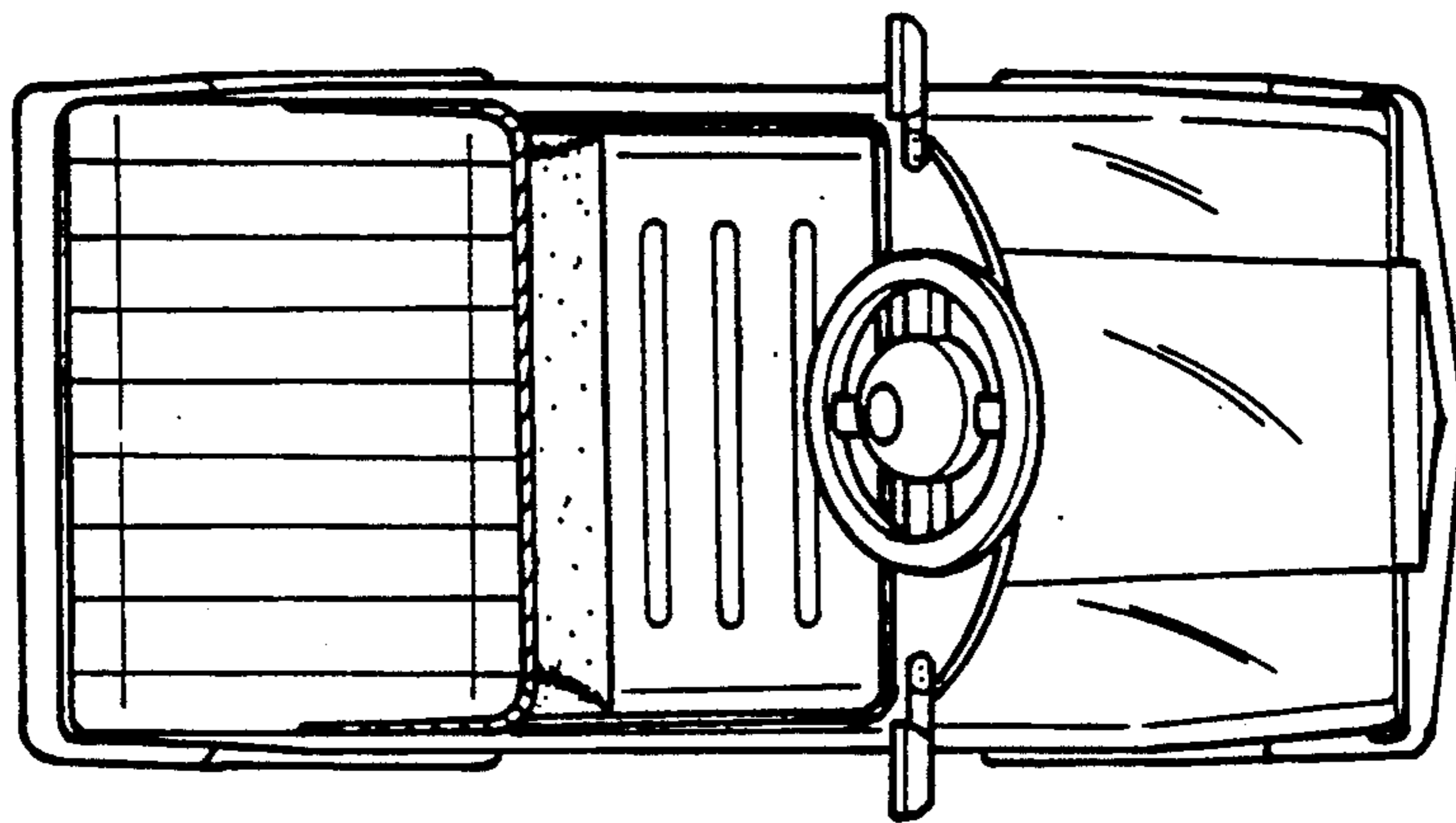

FIG. 2

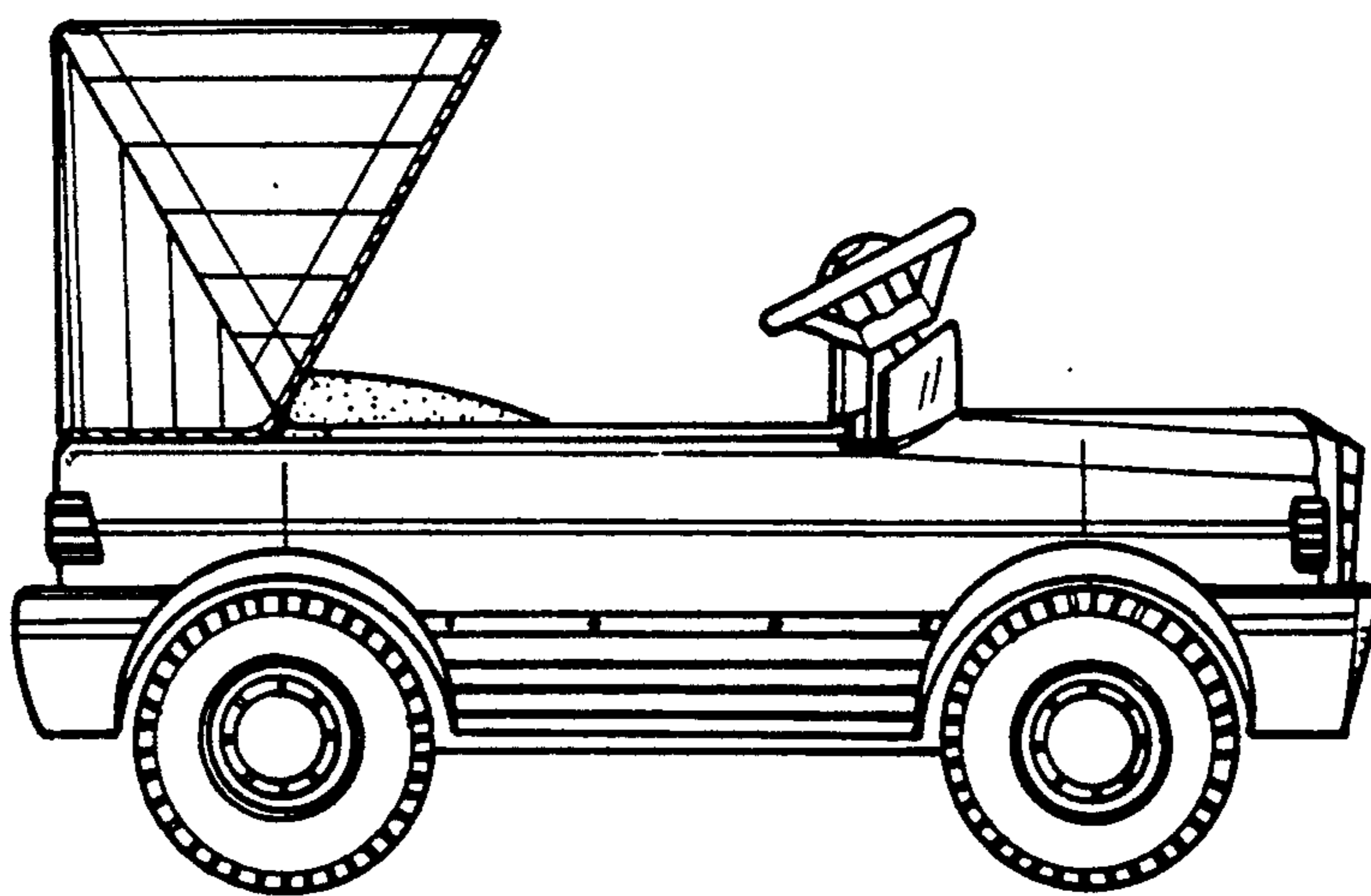

FIG. 3

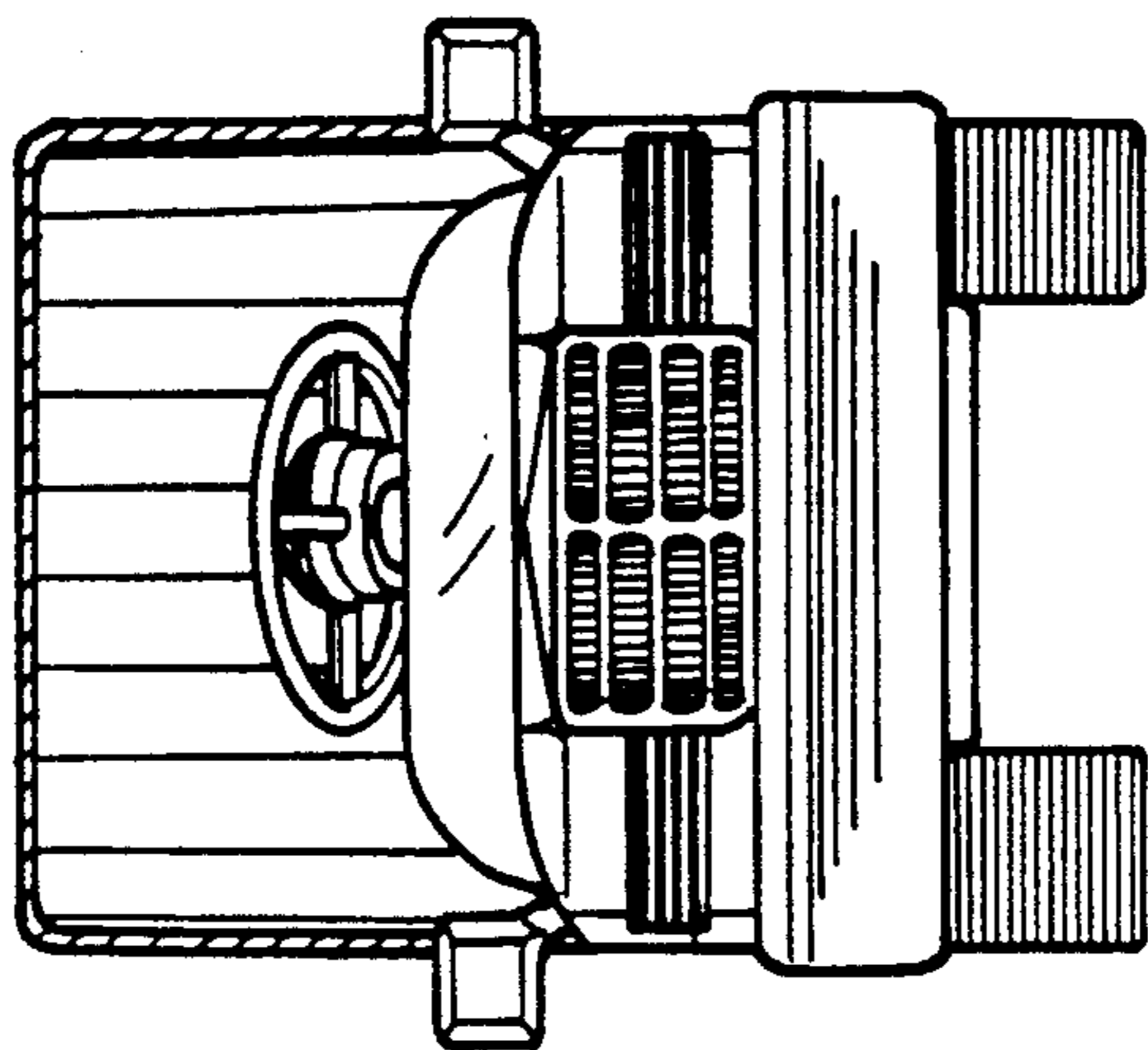

FIG. 5

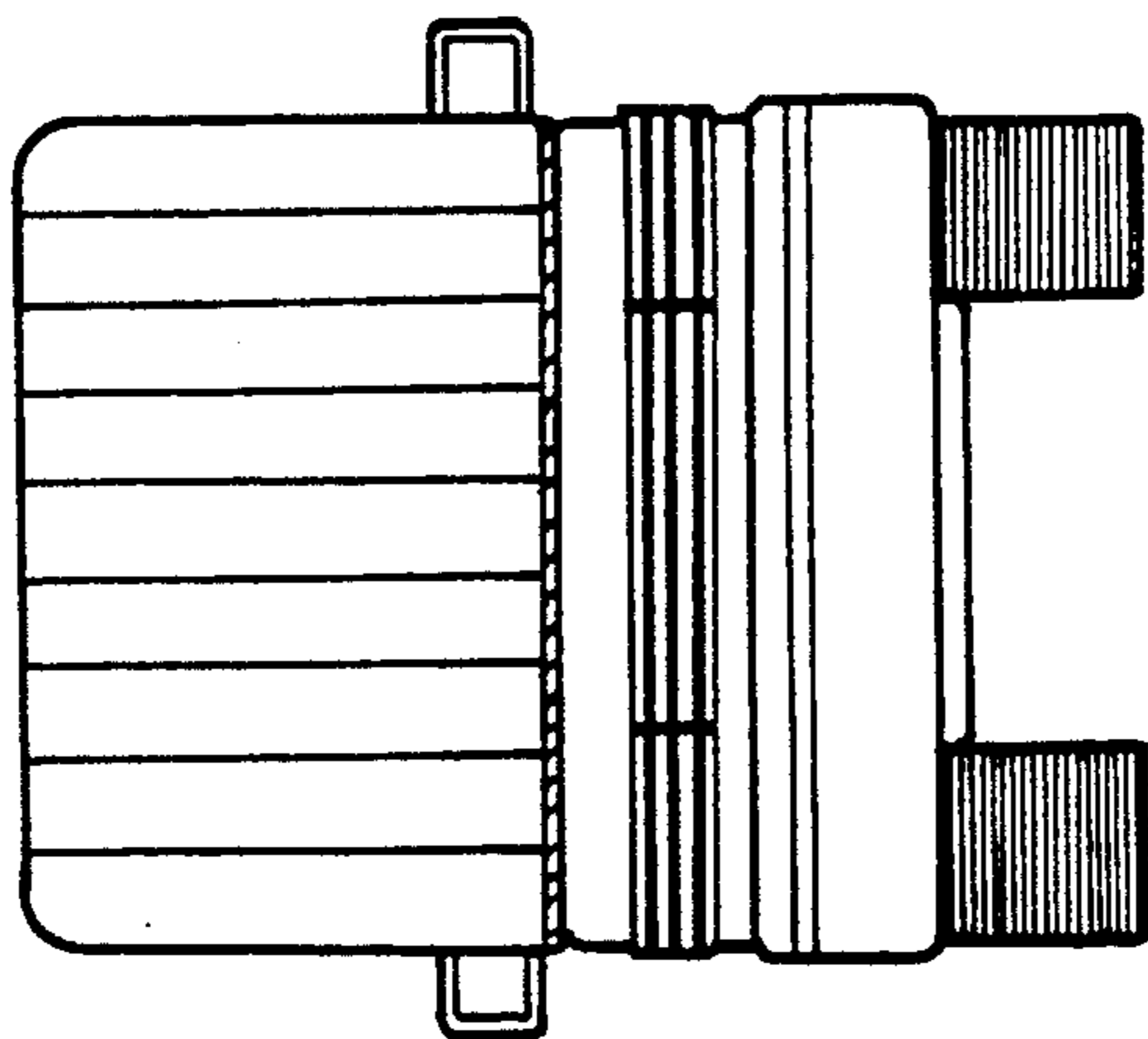

FIG. 4

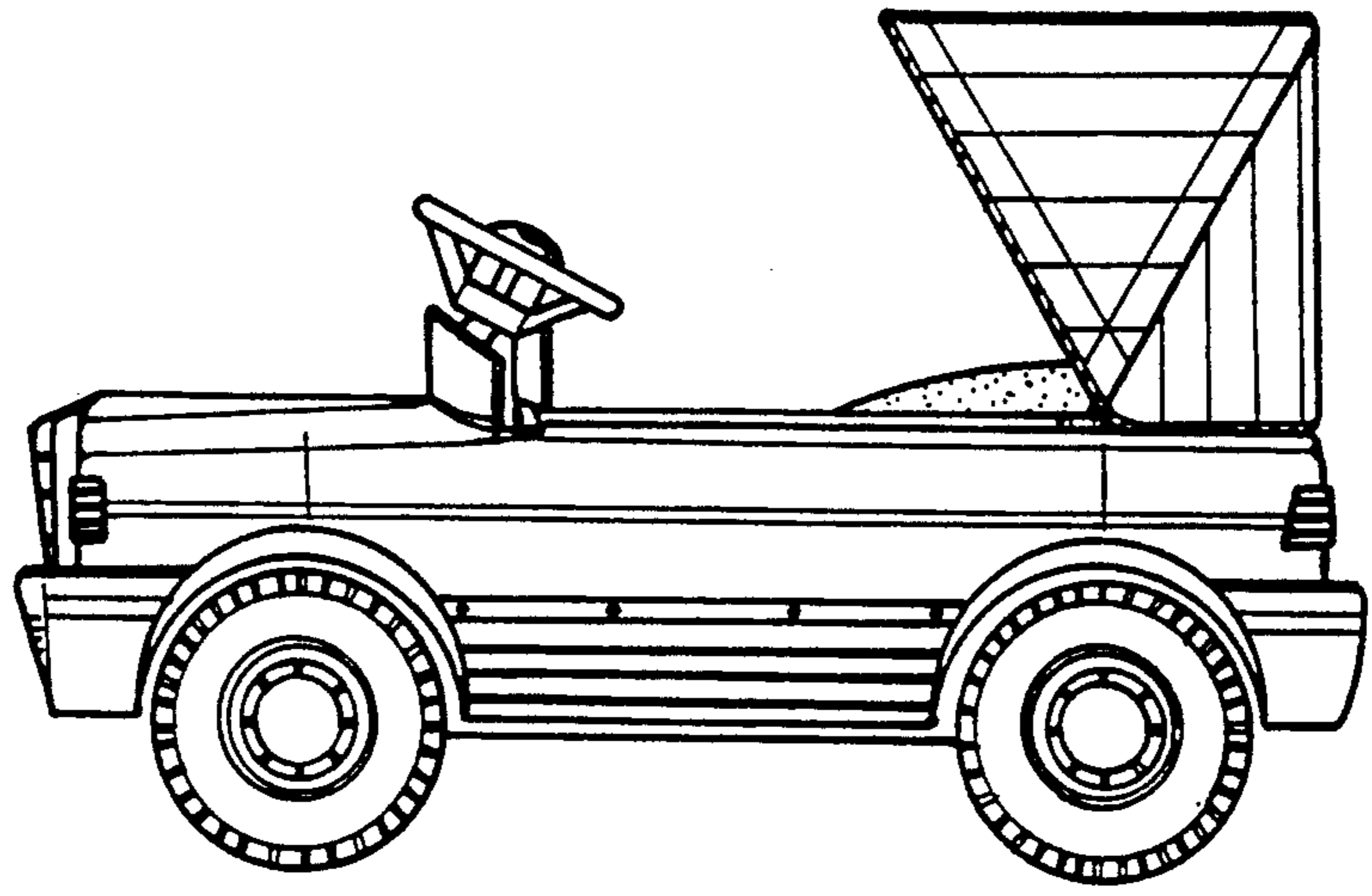

FIG. 6

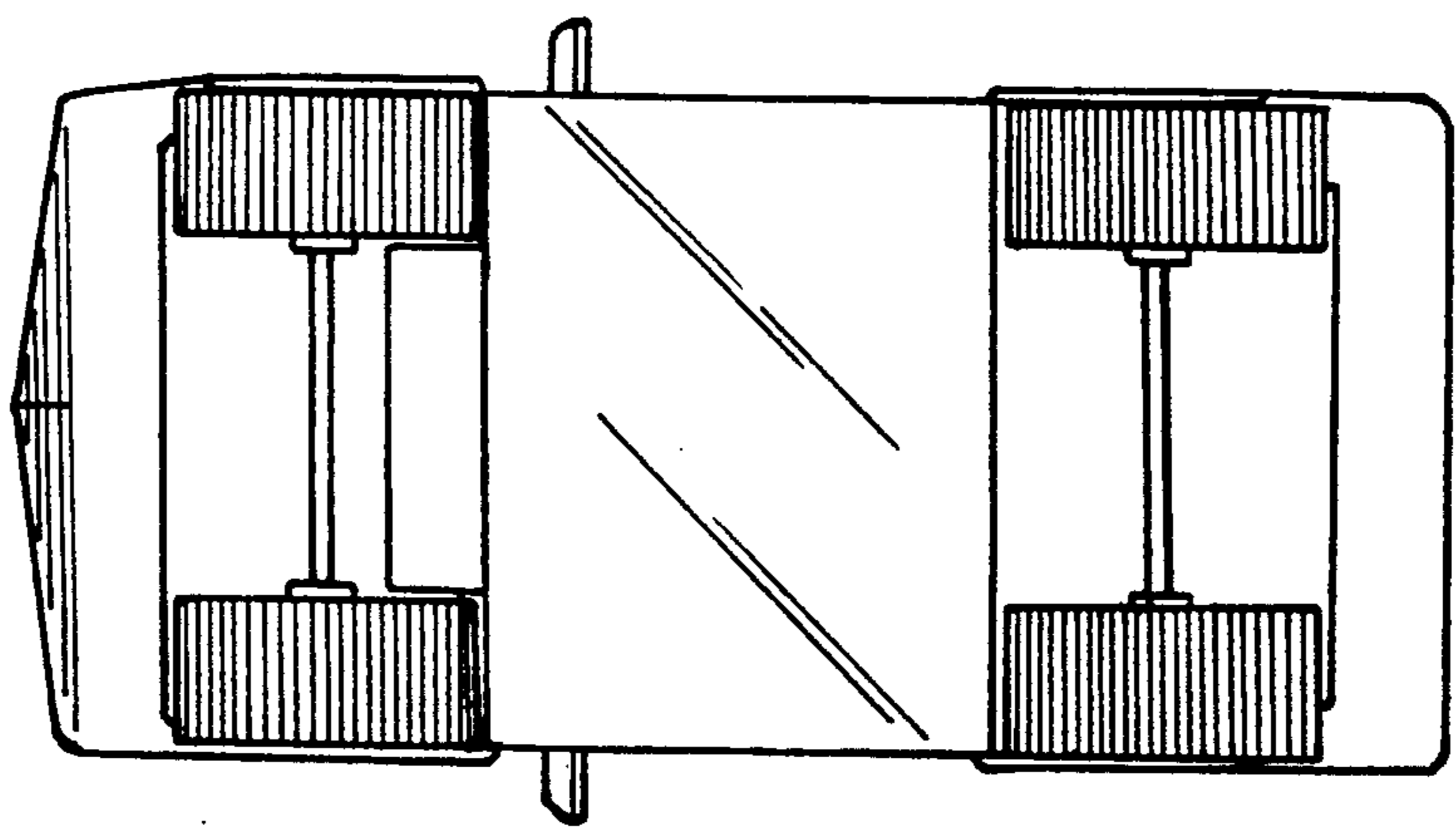

FIG. 7

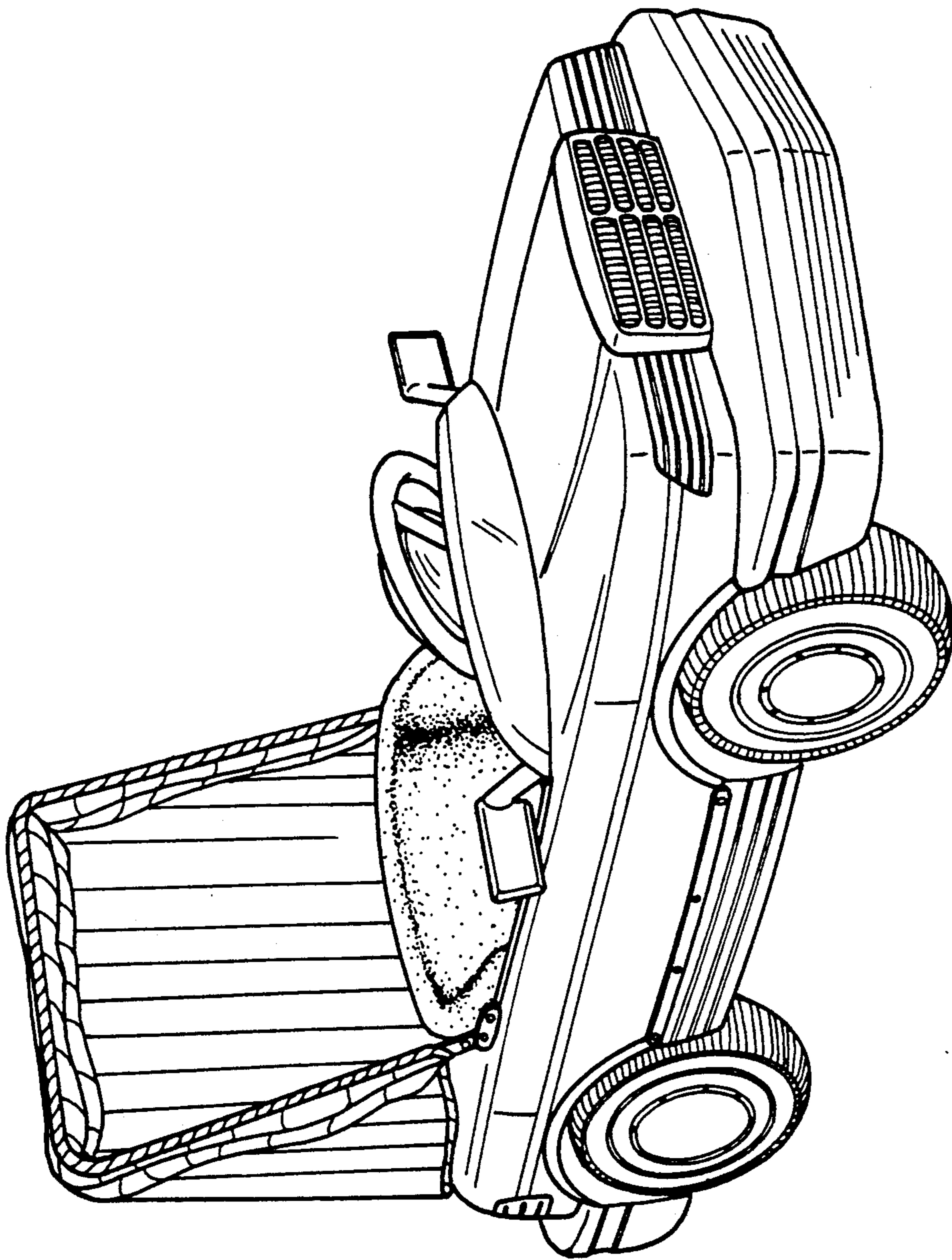

FIG. 8