



US00D324164S

United States Patent [19]

[11] Patent Number: **Des. 324,164**

Jan et al.

[45] Date of Patent: **** Feb. 25, 1992**

[54] **AUTOMOBILE STEERING WHEEL LOCK**

4,103,524 8/1978 Mitchell et al. 70/209
4,935,047 6/1990 Wu 70/209

[76] Inventors: **Shwu-Meei Jan**, No. 7-2, Alley 13, Lane 54, Sec. 2, Hsing-Nan Road, Jung-Heh, Taipei Hsien; **Hsien-Pao Chen**, No. 76, Lane 274, Jung-Jeng S. Road, Yung-Kang Shiang, Tainan Hsien, both of Taiwan

FOREIGN PATENT DOCUMENTS

2039840 8/1980 United Kingdom 70/209 X

Primary Examiner—Brian N. Vinson
Attorney, Agent, or Firm—Bacon & Thomas

[**] Term: **14 Years**

[57] CLAIM

[21] Appl. No.: **593,632**

The ornamental design for an automobile steering wheel lock, as shown.

[22] Filed: **Oct. 5, 1990**

DESCRIPTION

[52] U.S. Cl. **D8/331**

[58] Field of Search **D8/330-346;**
70/207-211, 214-217, 225-227, 237-238,
252-253

FIG. 1 is a top, front, and left side perspective view of an automobile steering wheel lock showing our new design;

FIG. 2 is a front elevational view thereof;

FIG. 3 is a rear elevational view thereof;

FIG. 4 is a left side elevational view thereof;

FIG. 5 is a right side elevational view thereof;

FIG. 6 is a top plan view thereof; and

FIG. 7 is a bottom plan view thereof.

[56] References Cited

U.S. PATENT DOCUMENTS

D. 289,491 4/1987 Johnson D8/330
D. 312,202 11/1990 Wang D8/331 X

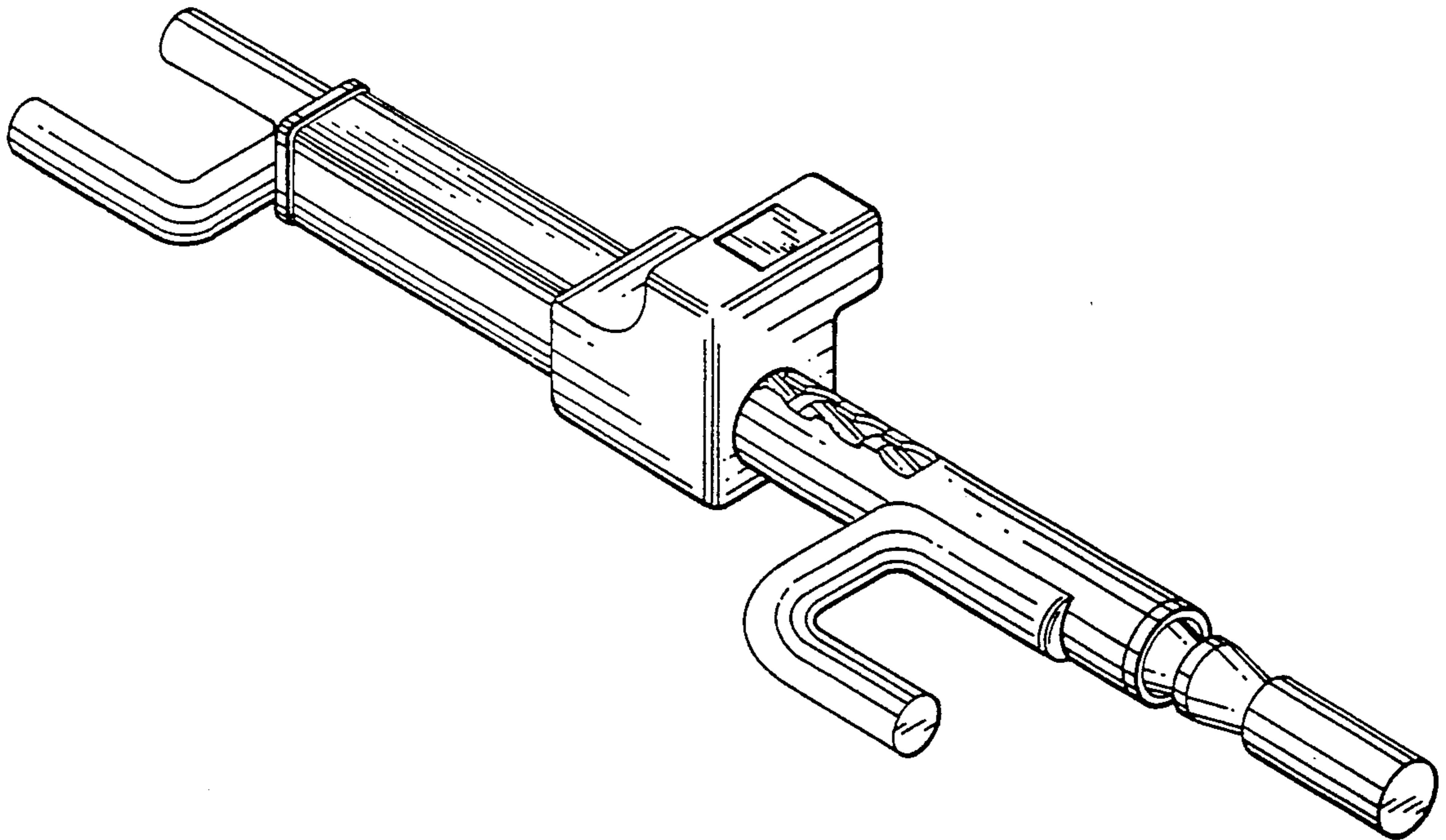

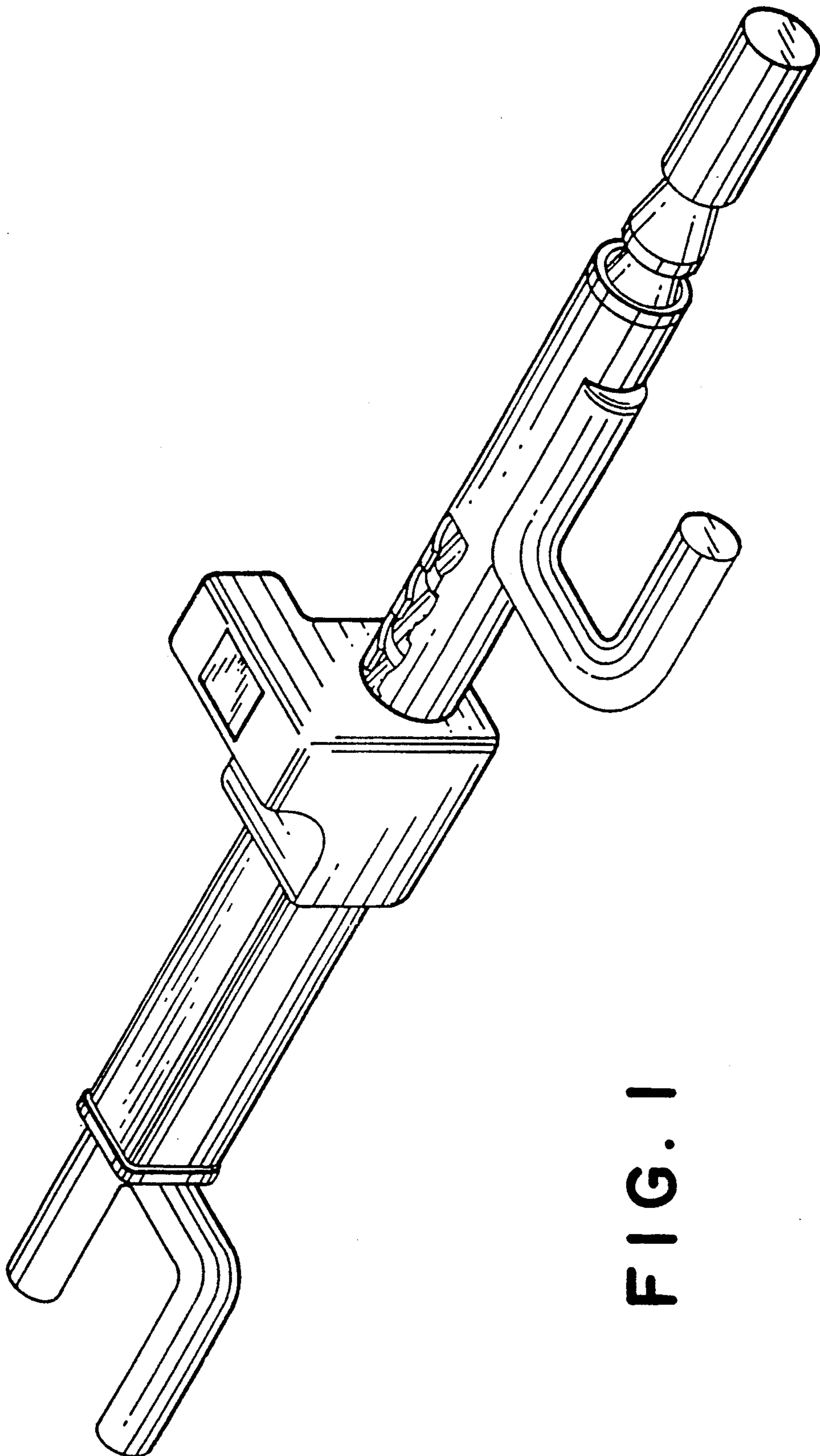

FIG. 1

FIG. 2

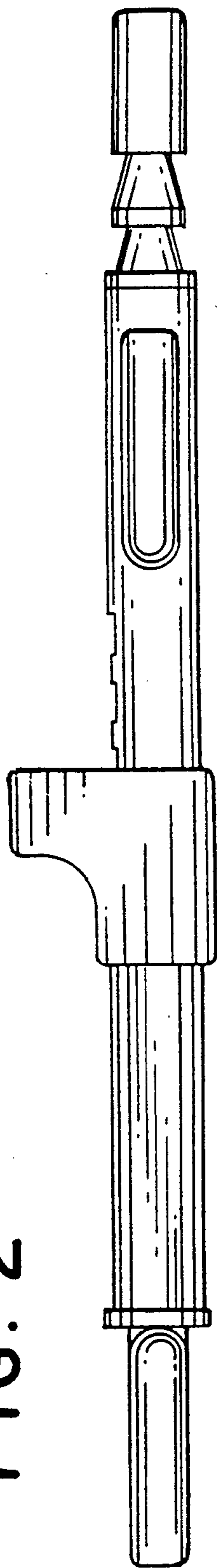

FIG. 3

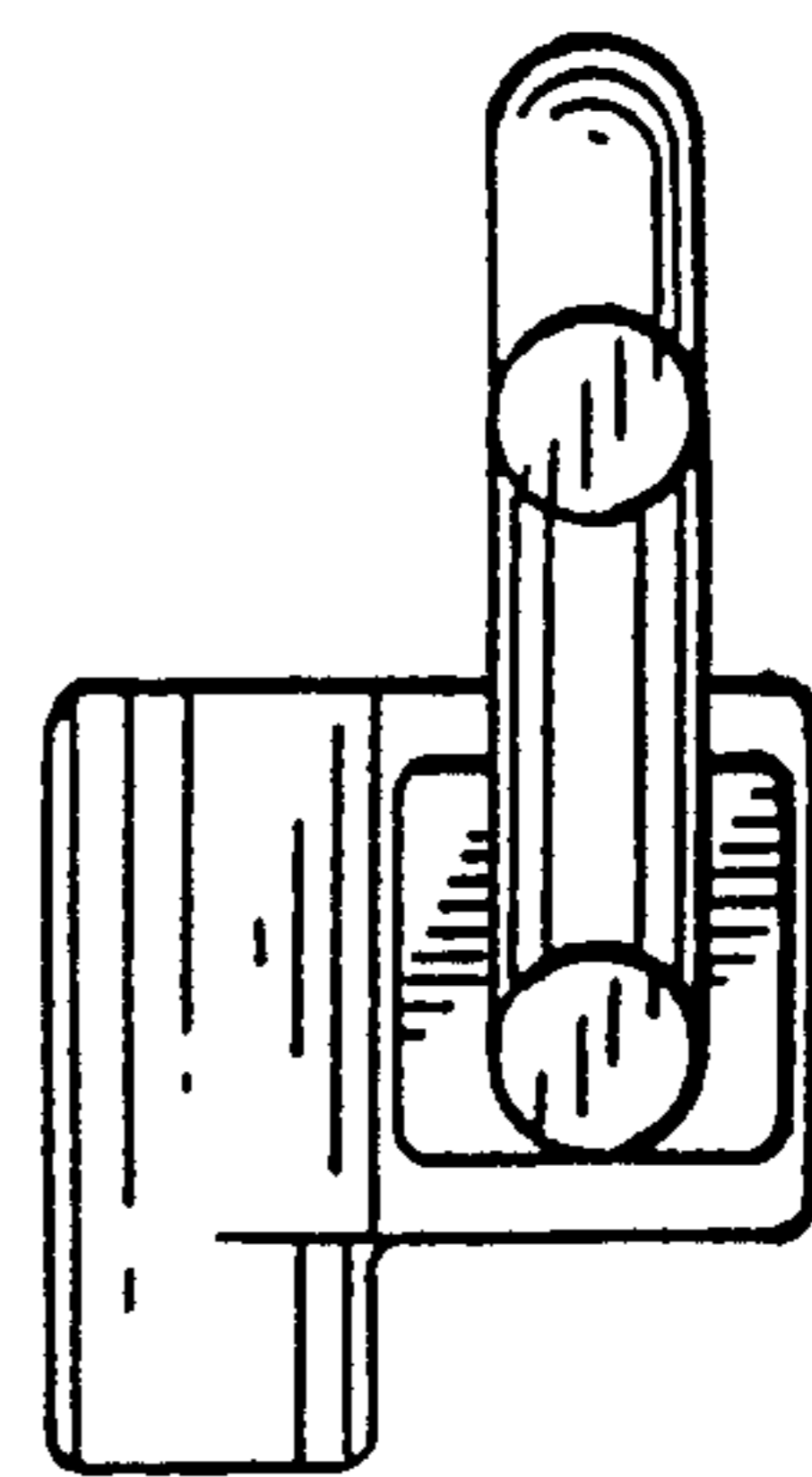
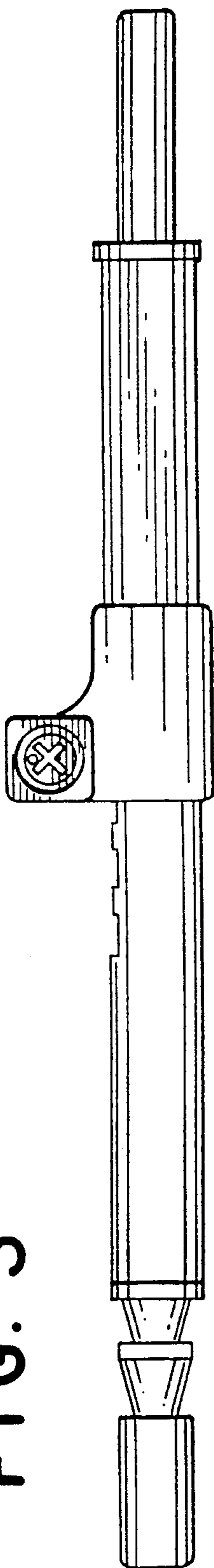

FIG. 4

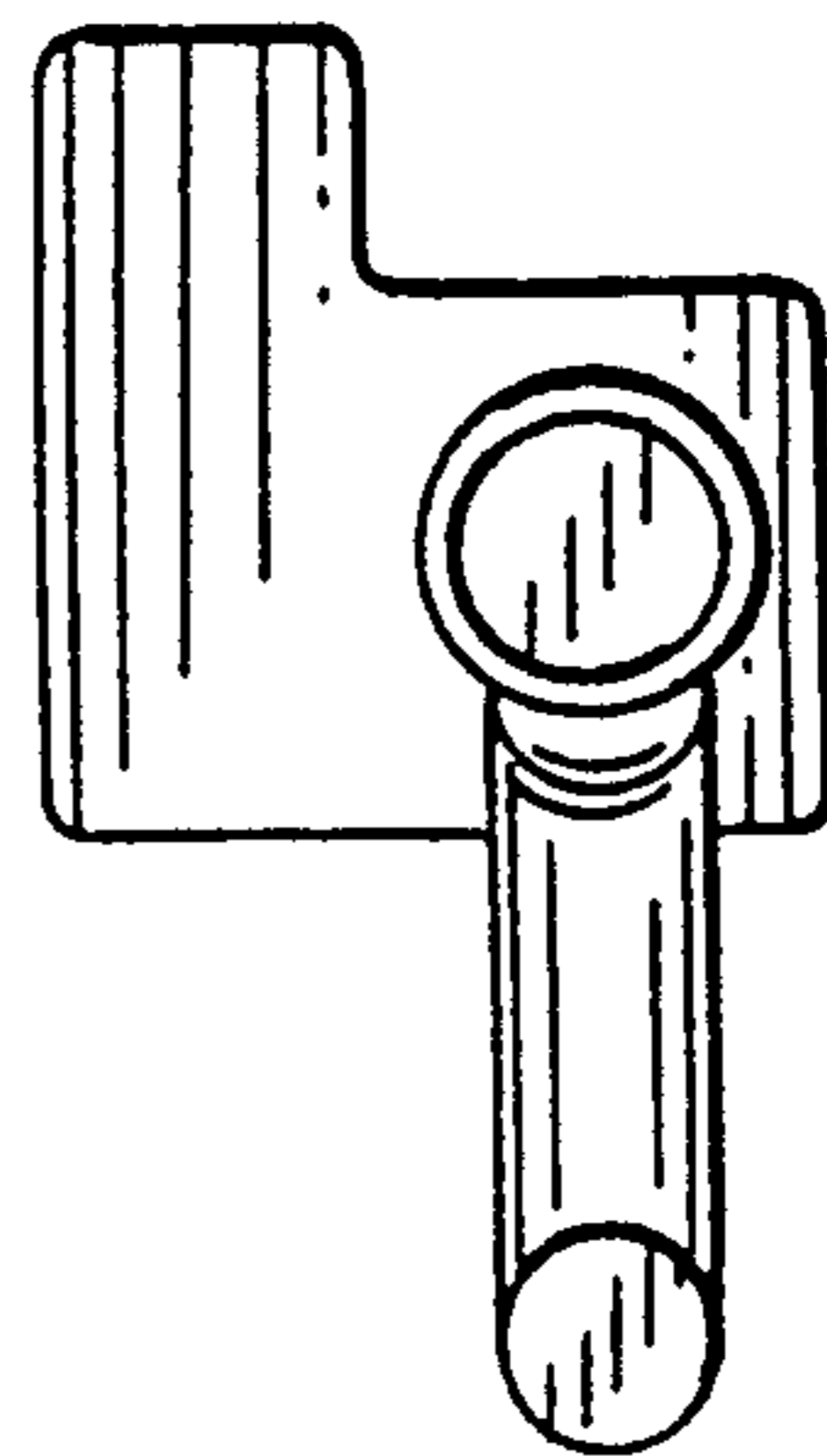

FIG. 5

FIG. 6

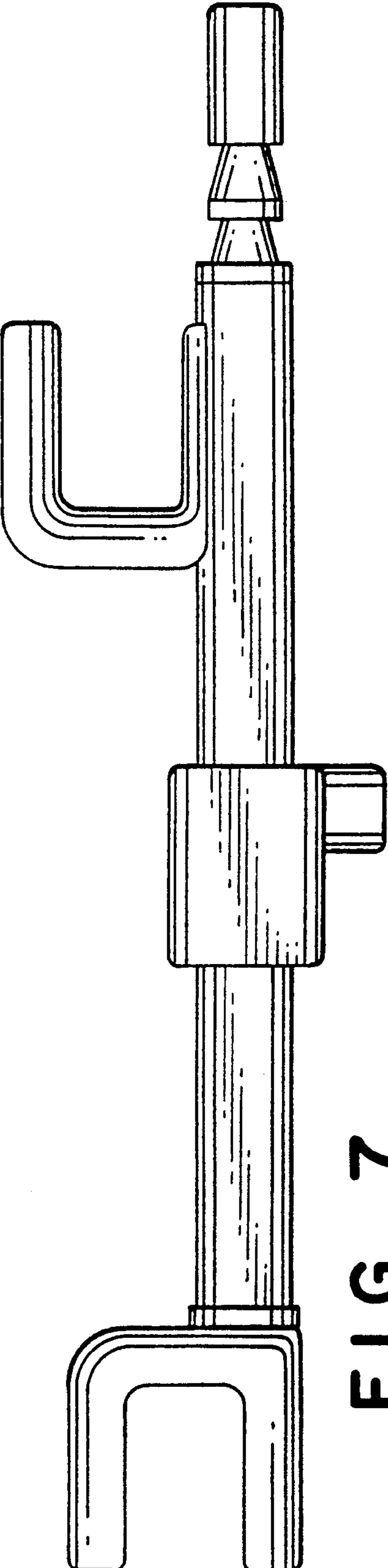
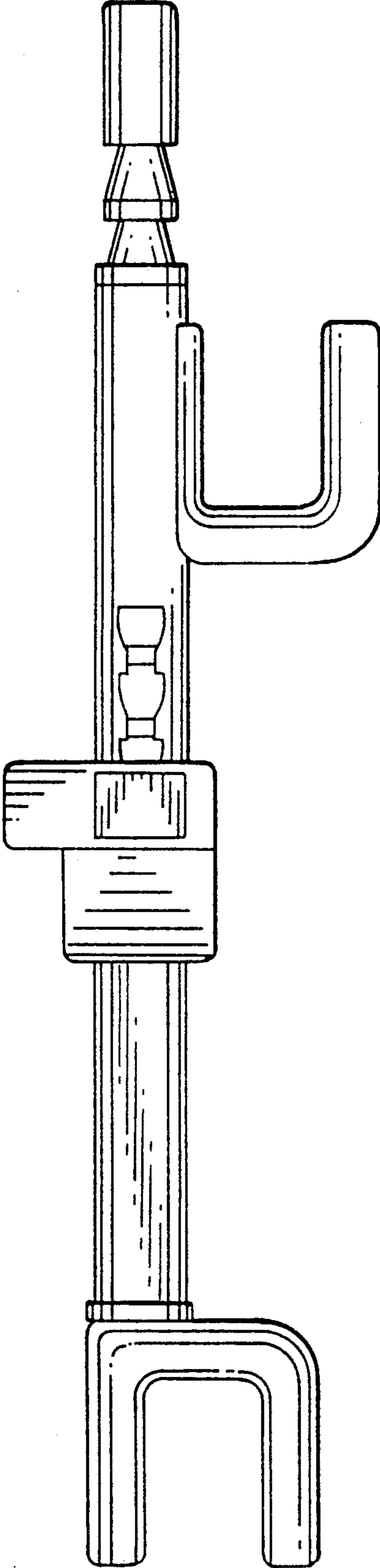

FIG. 7