



US00D324147S

United States Patent [19]

[11] Patent Number: **Des. 324,147**

Tcheng et al.

[45] Date of Patent: **** Feb. 25, 1992**

[54] **END STANDARD FOR A VEHICLE SEAT OR SIMILAR ARTICLE**

[75] Inventors: **John Tcheng; John F. Branham**, both of Buckinghamshire, England

[73] Assignees: **John F. Branham, Aylesburg; Flight Equip. & Engineering Ltd.**, Chesham, both of England

[**] Term: **14 Years**

[21] Appl. No.: **284,448**

[22] Filed: **Dec. 14, 1988**

[30] **Foreign Application Priority Data**

Jun. 18, 1988 [GB] United Kingdom 1051702
Jun. 18, 1988 [GB] United Kingdom 1051703

[52] U.S. Cl. **D6/500**

[58] Field of Search D6/491-495,
D6/499-503, 505, 507, 510, 356; 297/165, 167,
168, 126, 192, 445, 446, 183; 244/122 R

[56] **References Cited**

U.S. PATENT DOCUMENTS

D. 40,044	6/1909	Cogger	D6/492
D. 238,994	3/1976	Schultz	D6/501
2,933,127	4/1960	Brewster	244/122 R X
3,468,582	9/1969	Judd	297/445
4,375,300	3/1983	Long et al.	297/445 X

Primary Examiner—Bruce W. Dunkins
Assistant Examiner—Janice E. Seeger
Attorney, Agent, or Firm—Watson, Cole, Grindle & Watson

[57] **CLAIM**

The ornamental design for an end standard for a vehicle seat or similar article, as shown and described.

DESCRIPTION

FIG. 1 is a side elevational view of an end standard for a vehicle seat or similar article, showing my new design; FIG. 2 is an elevational view, showing the side not shown in FIG. 1;

FIG. 3 is a cross sectional view, taken along line 3—3 in FIG. 2;

FIG. 4 is a cross sectional view, taken along line 4—4 in FIG. 2;

FIG. 5 is a top plan view; and

FIG. 6 is a bottom plan view thereof.

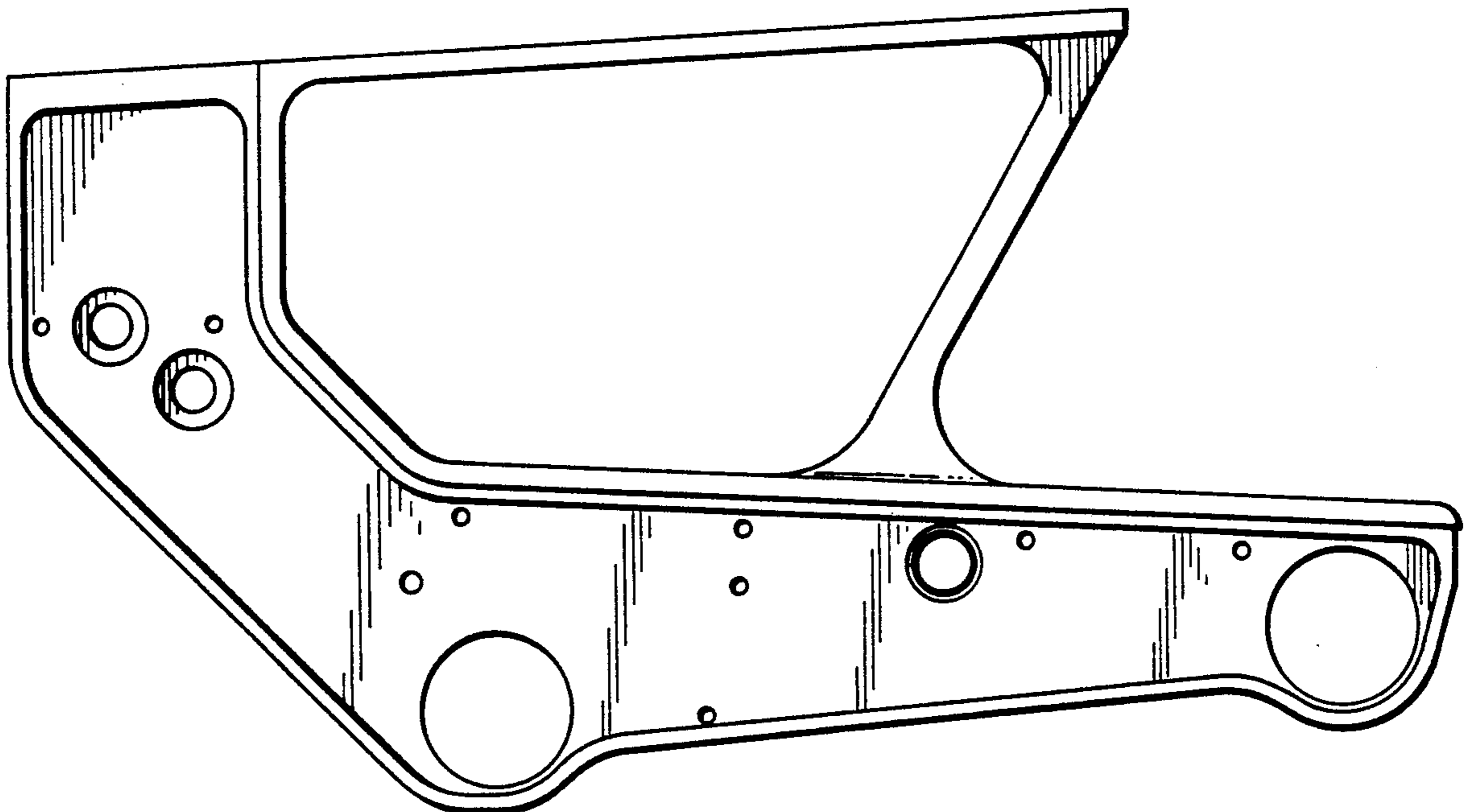

FIG. 1

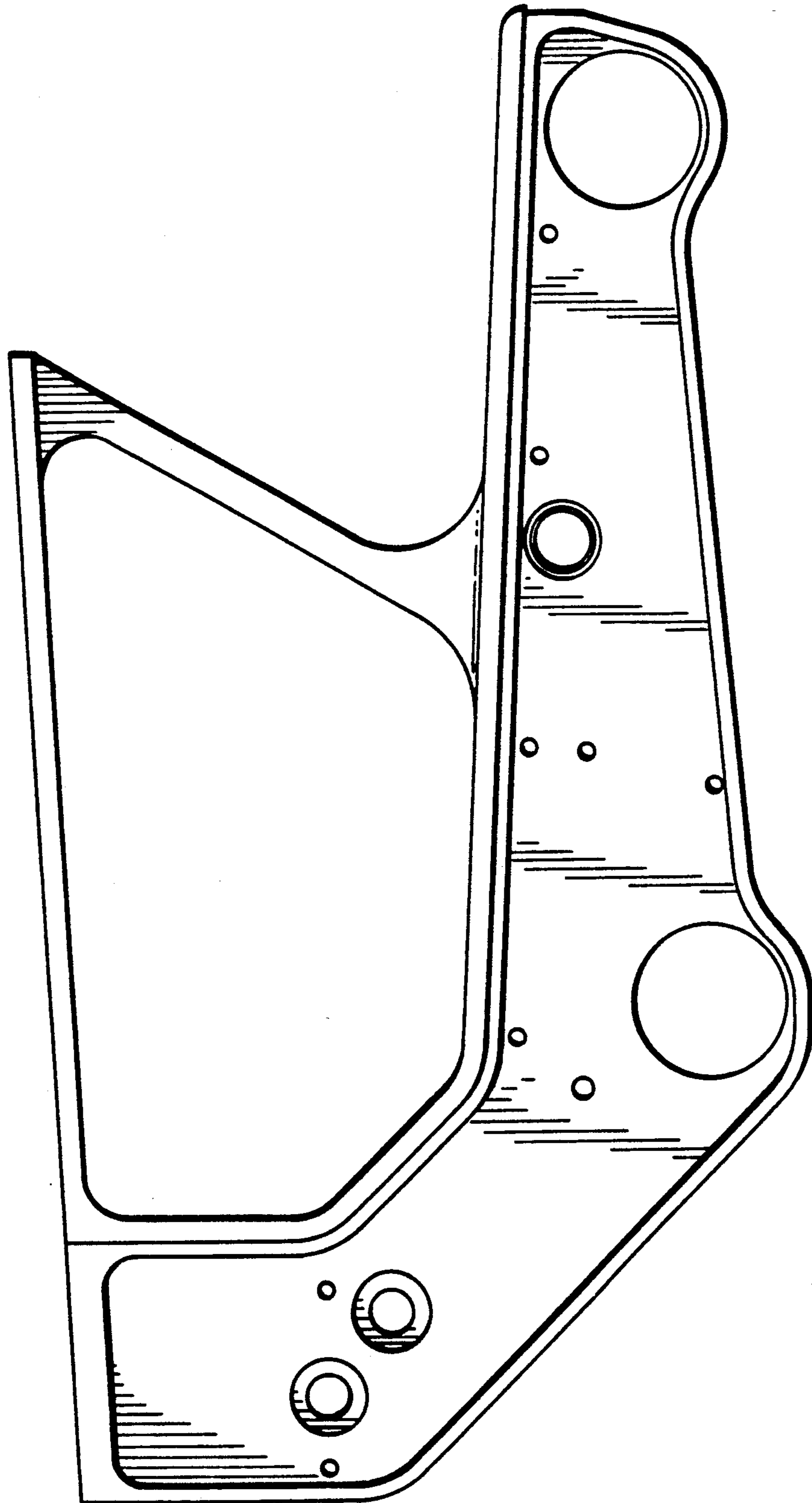
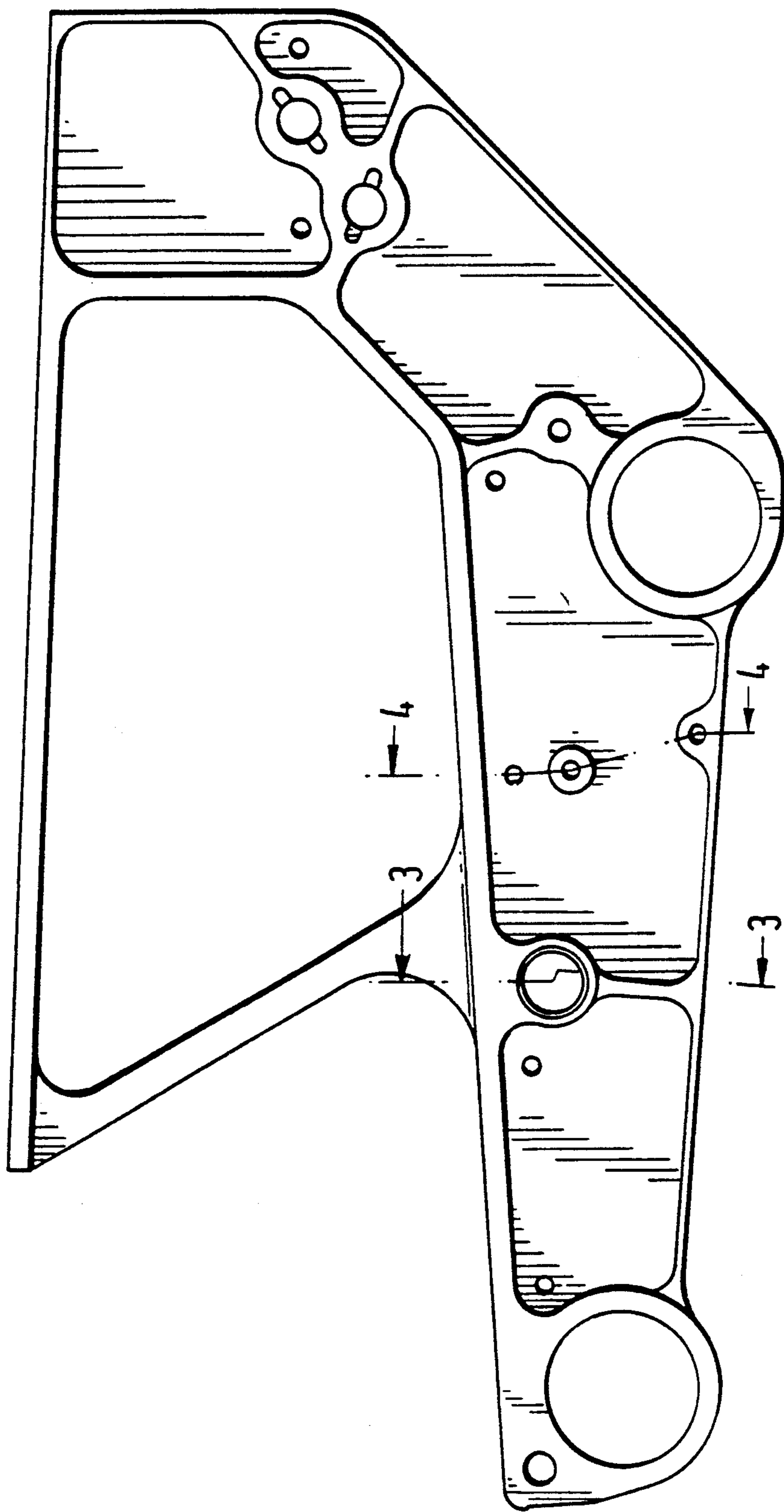

FIG. 2



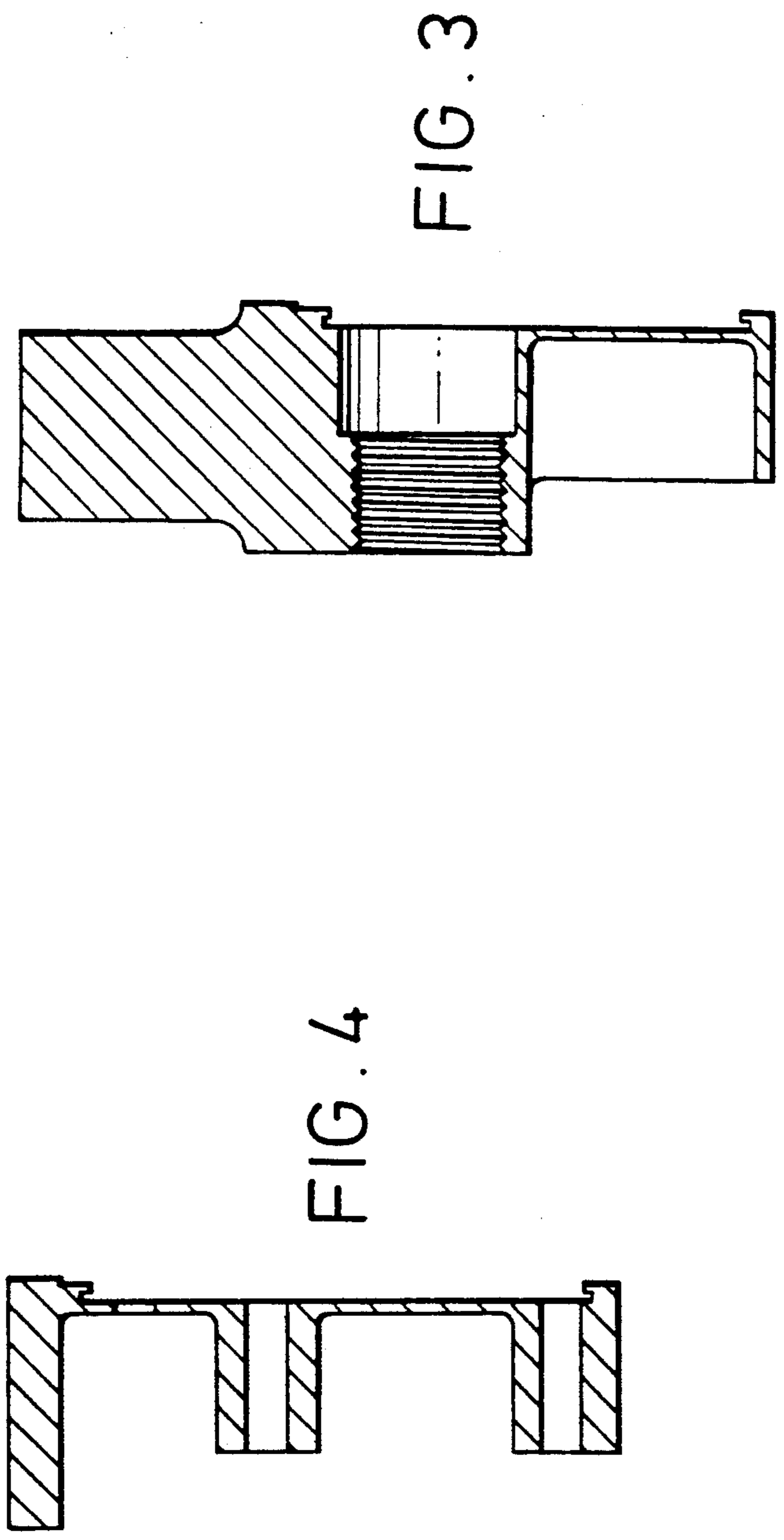

FIG. 4

FIG. 3

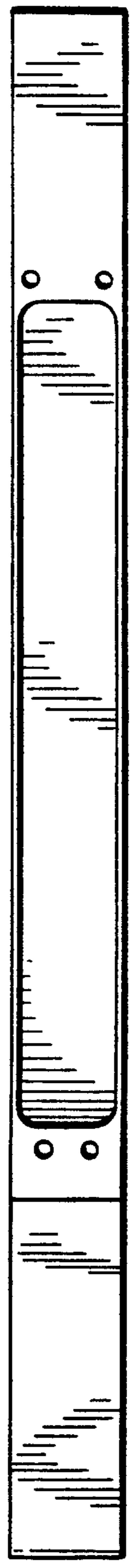

FIG. 5

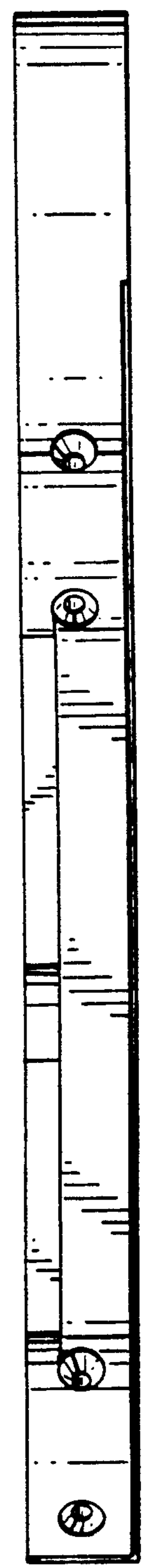

FIG. 6