



US00D324090S

United States Patent [19]

[11] Patent Number: **Des. 324,090**

Miller

[45] Date of Patent: **** Feb. 18, 1992**

[54] RECUMBENT EXERCISE CYCLE

[75] Inventor: **Randolph F. Miller, Mount Vernon, Wash.**

[73] Assignee: **Tunturi, Inc., Redmond, Wash.**

[**] Term: **14 Years**

[21] Appl. No.: **527,262**

[22] Filed: **May 22, 1990**

[52] U.S. Cl. **D21/194**

[58] Field of Search **D21/191-199;**
272/73, 70.3, 132, DIG. 6; 73/379

[56] References Cited

U.S. PATENT DOCUMENTS

D. 299,669	1/1989	Harter	D21/194
D. 305,348	1/1990	Schurink et al.	D21/194
D. 305,677	1/1990	Beistegui	D21/194
D. 308,085	5/1990	Alberta	D21/194
D. 316,887	5/1991	Lo et al.	D21/194
D. 318,086	7/1991	Bingham et al.	D21/194
4,953,850	9/1990	Lo	272/73

OTHER PUBLICATIONS

Brochure of Tonic Sport Manufacturing Co., Ltd., relating to TG-540 Recumbent Ergocycle.
Brochure of Engineering Dynamics Corporation relating to BIOCYCLE EM610.

Brochure of PRO-FORM FITNESS PRODUCTS, INC. relating to AIR CYCLIST.

Brochure of Precor, Incorporated relating to PRECOR 815e Semi-Recumbent Stationary Cycle.

Brochure of Nautilus showing Recumbent Exercise Bike.

Brochure of Marcy Fitness Products relating to Recumbent Exercise Module Rem Plus.

Brochure of Pro-Tec Sports International relating to PTS Turbo 1000 Exercise Bike.

Brochure of Fitness Quest relating to Recline Rider.

Brochure of IMPEX, Inc., relating to Fitness Rider FR2000AP.

Primary Examiner—Charles A. Rademaker
Attorney, Agent, or Firm—Graybeal Jackson Haley & Johnson

[57] CLAIM

The ornamental design for a recumbent exercise cycle, as shown and described.

DESCRIPTION

FIG. 1 is a rear perspective view of a recumbent exercise cycle showing my new design; FIG. 2 is a right side elevational view thereof, the side opposite being substantially a mirror image; FIG. 3 is a front elevational view thereof; FIG. 4 is a rear elevational view thereof; FIG. 5 is a bottom plan view thereof; and, FIG. 6 is a top plan view thereof.

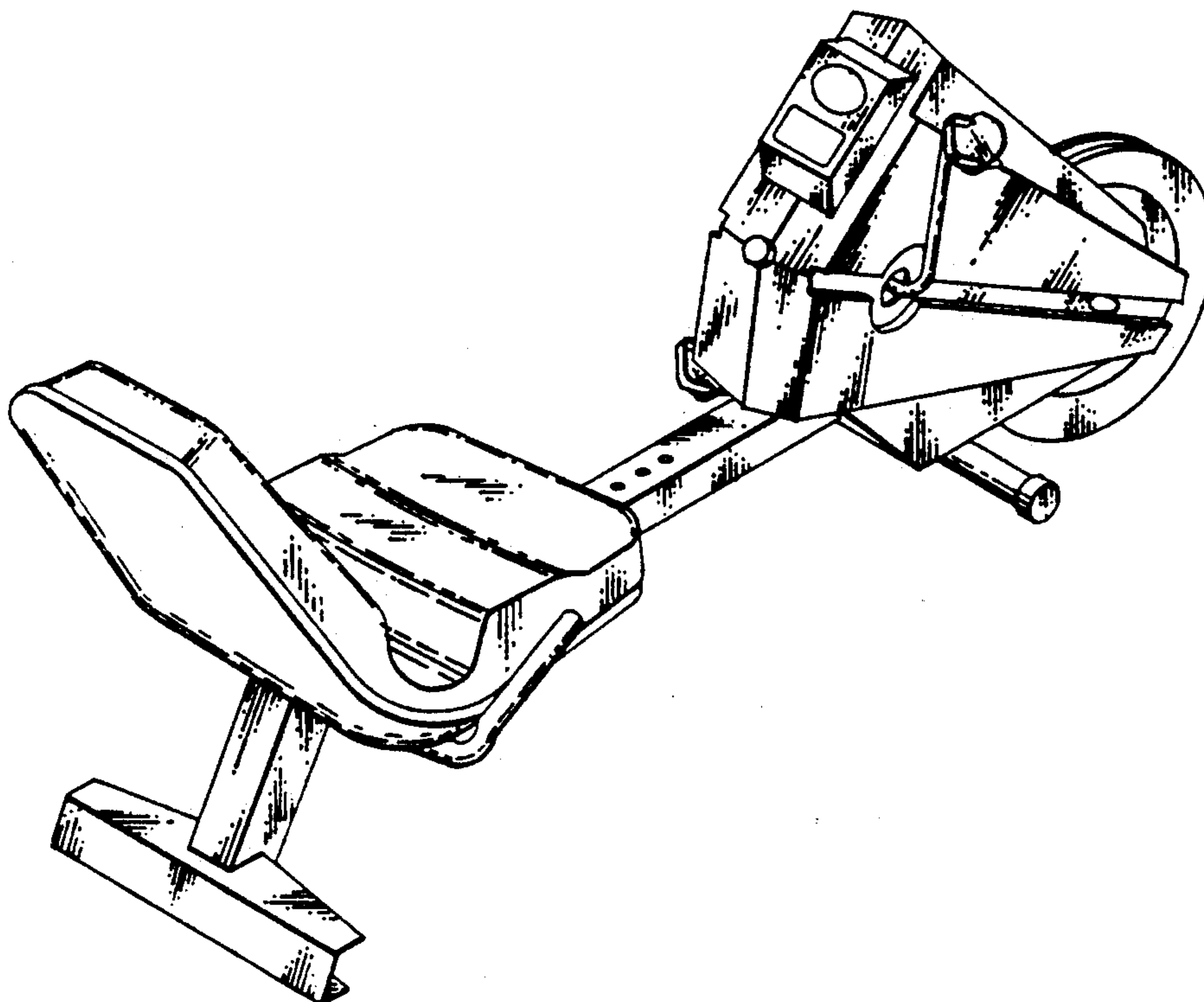

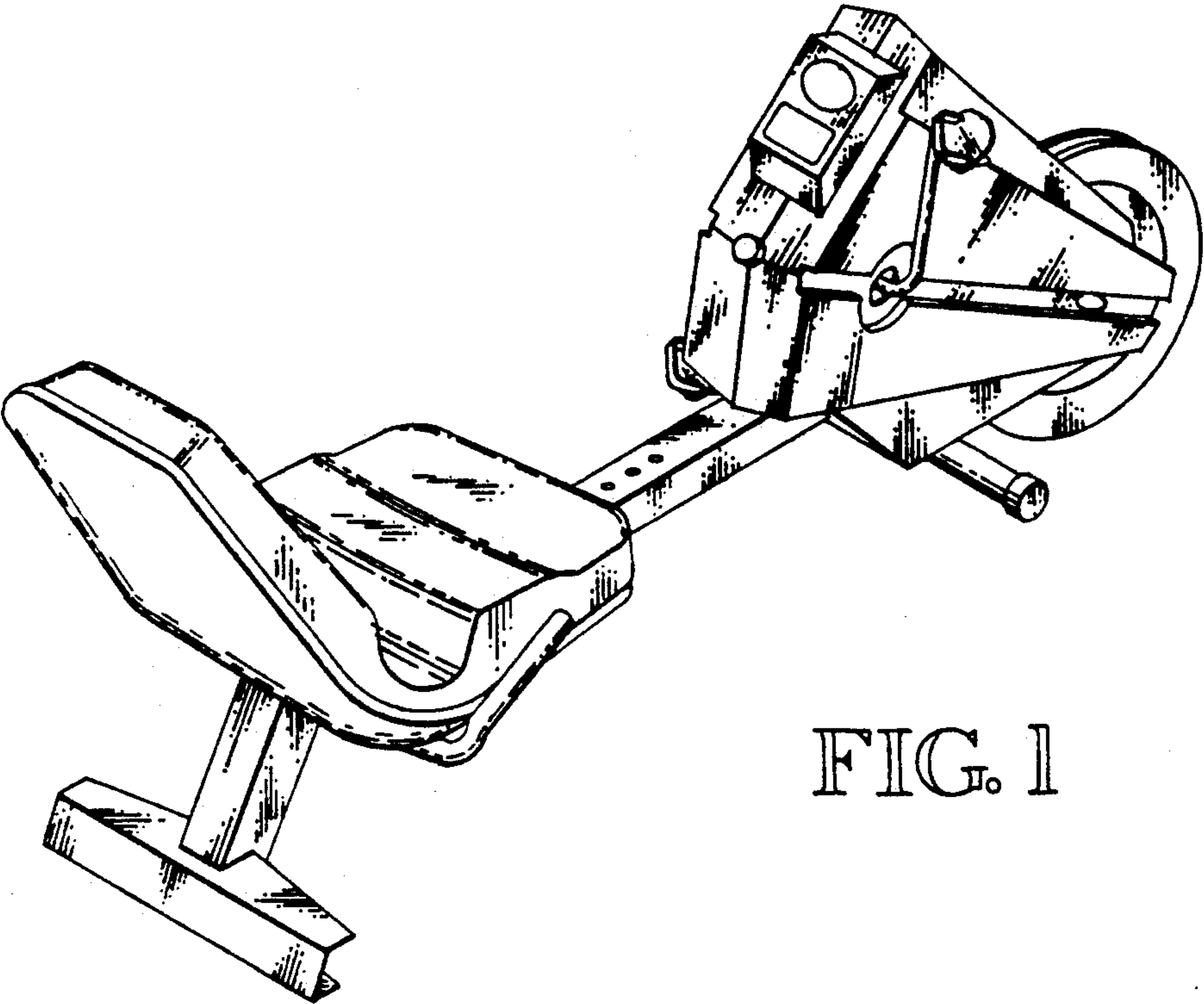
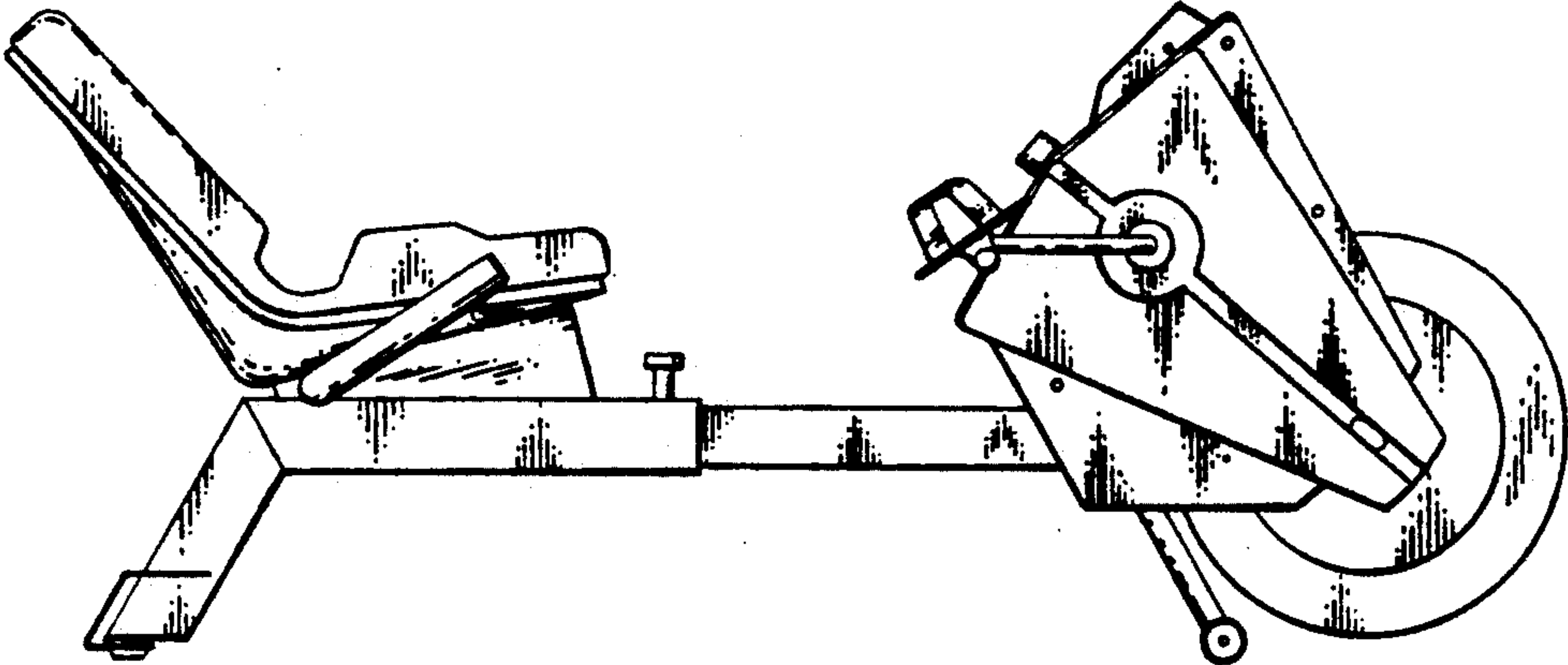

FIG. 1

FIG. 2



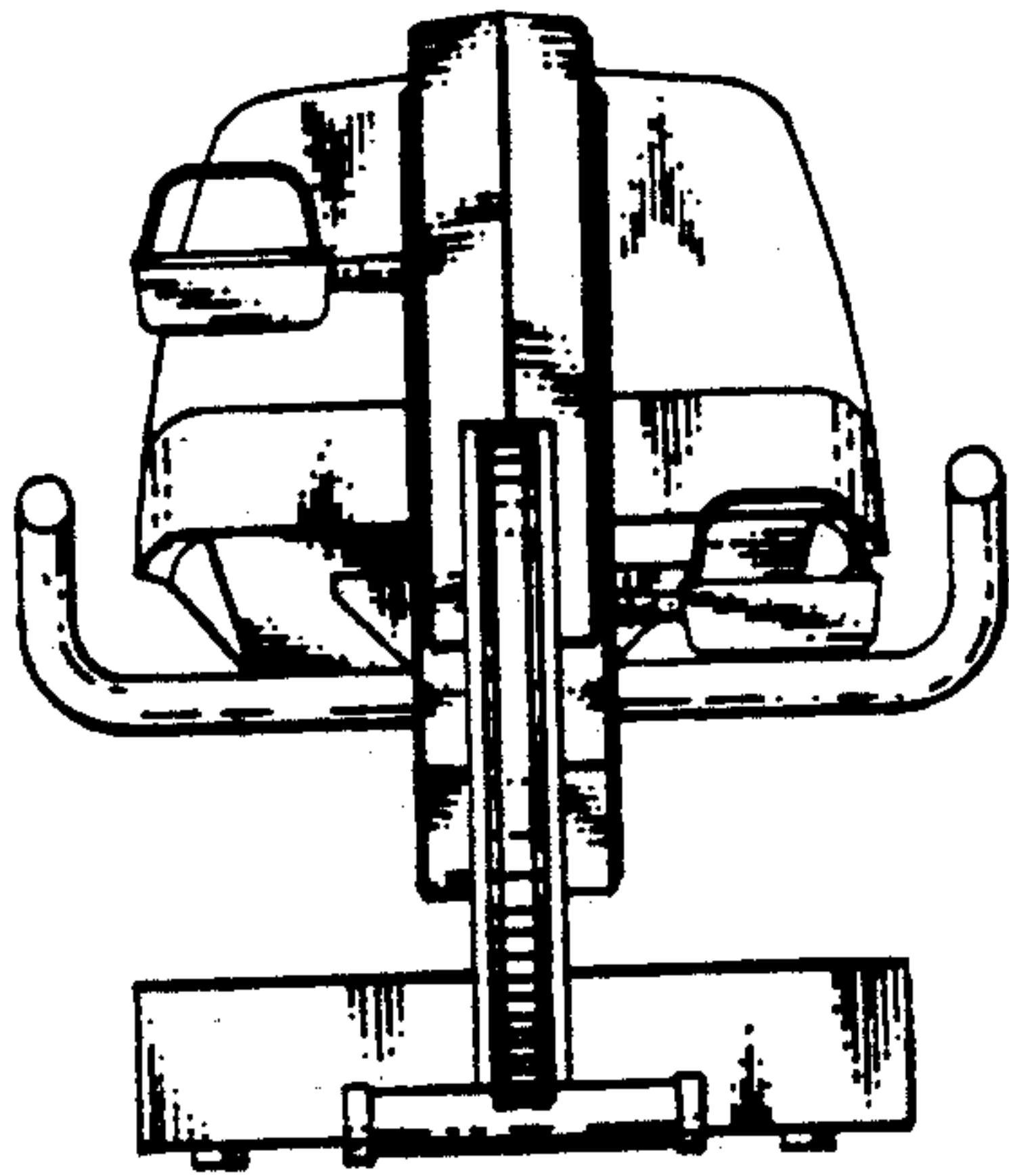

FIG. 3

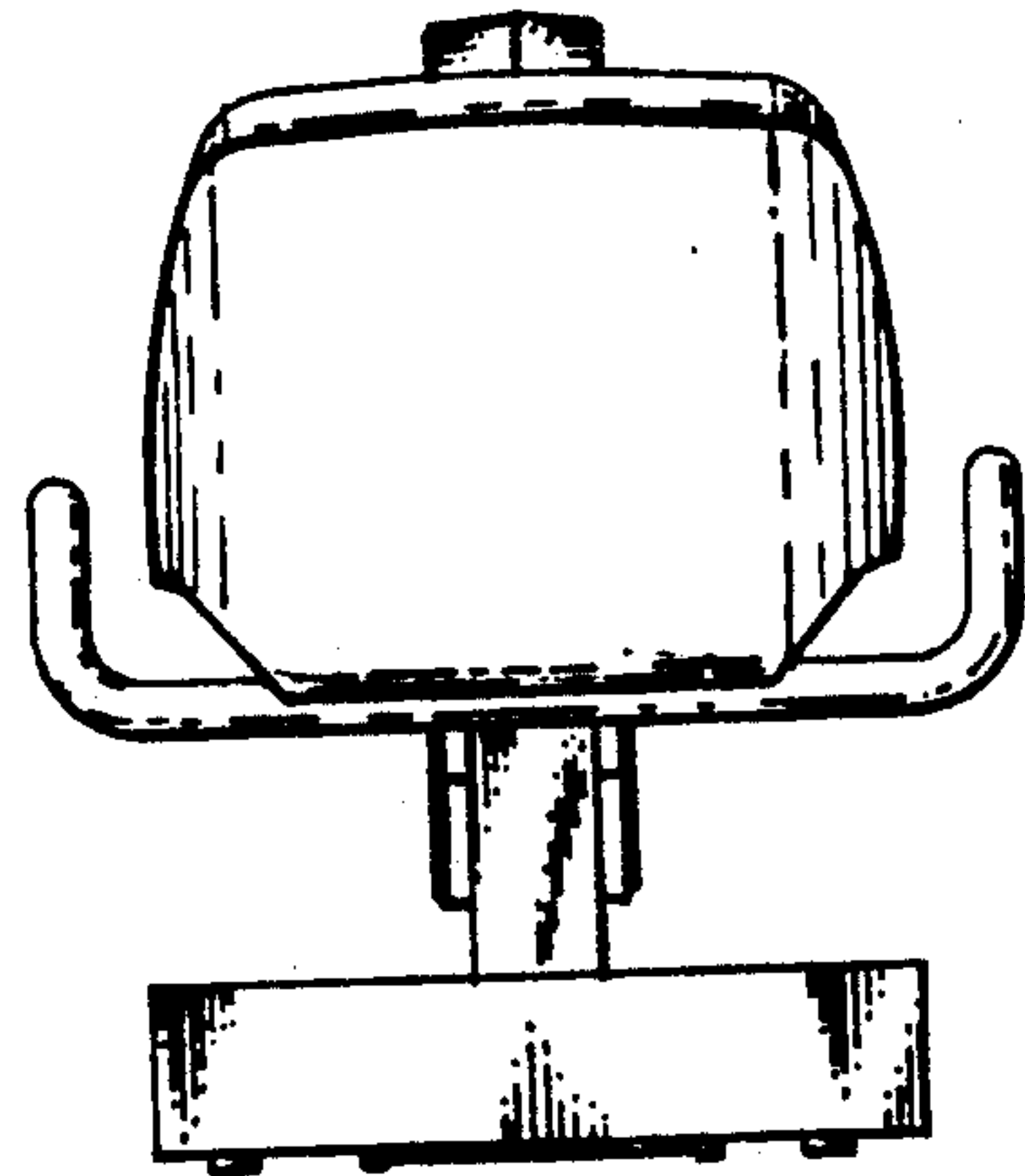

FIG. 4

FIG. 5

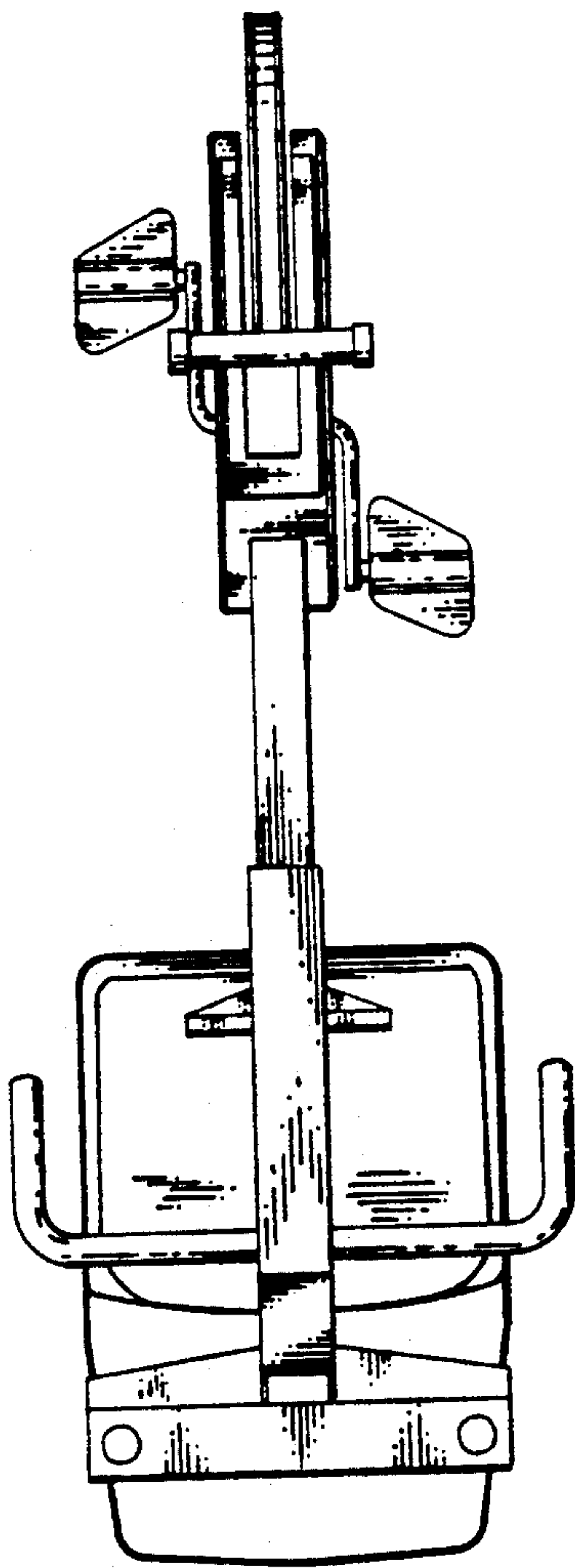

FIG. 6

