



US00D323961S

# United States Patent [19]

Fushiya et al.

[11] Patent Number: **Des. 323,961**

[45] Date of Patent: **\*\* Feb. 18, 1992**

[54] **PORTABLE ELECTRIC DRILL**

[75] Inventors: **Fusao Fushiya; Michio Okumura,**  
both of Anjo, Japan

[73] Assignee: **Makita Electric Works, Ltd., Anjo,**  
Japan

[\*\*] Term: **14 Years**

[21] Appl. No.: **388,351**

[22] Filed: **Aug. 2, 1989**

[30] **Foreign Application Priority Data**

Feb. 7, 1989 [JP] Japan ..... 1-4230

[52] U.S. Cl. .... **D8/61**

[58] Field of Search ..... **D8/61, 68, 62;**  
**D4/100-102; D19/53; 81/54, 57.11, 57.13,**  
**57.14; 173/163**

[56] **References Cited**

**U.S. PATENT DOCUMENTS**

- D. 104,623 5/1937 Decker ..... D8/61
- D. 111,234 9/1938 Albertson ..... D8/61
- D. 131,659 3/1942 Decker ..... D8/61

- D. 150,531 8/1948 Albertson ..... D8/61
- D. 205,012 6/1966 Henggeler ..... D8/61
- D. 238,970 2/1976 Merion ..... D8/68
- D. 243,742 3/1977 House, II et al. .... D8/69
- D. 298,908 12/1988 Clemens ..... D8/61
- D. 301,496 6/1989 Yonesawa et al. .... D8/68

*Primary Examiner*—Nelson C. Holtje  
*Assistant Examiner*—J. H. Musgrove  
*Attorney, Agent, or Firm*—Dennison, Meserole, Pollack & Scheiner

[57] **CLAIM**

The ornamental design for a portable electric drill, as shown and described.

**DESCRIPTION**

FIG. 1 is a top front right side perspective view of a portable electric drill showing our new design; FIG. 2 is a right side elevational view; FIG. 3 is a left side elevational view; FIG. 4 is a front elevational view; FIG. 5 is a rear elevational view; FIG. 6 is a top plan view; and FIG. 7 is a bottom plan view thereof.

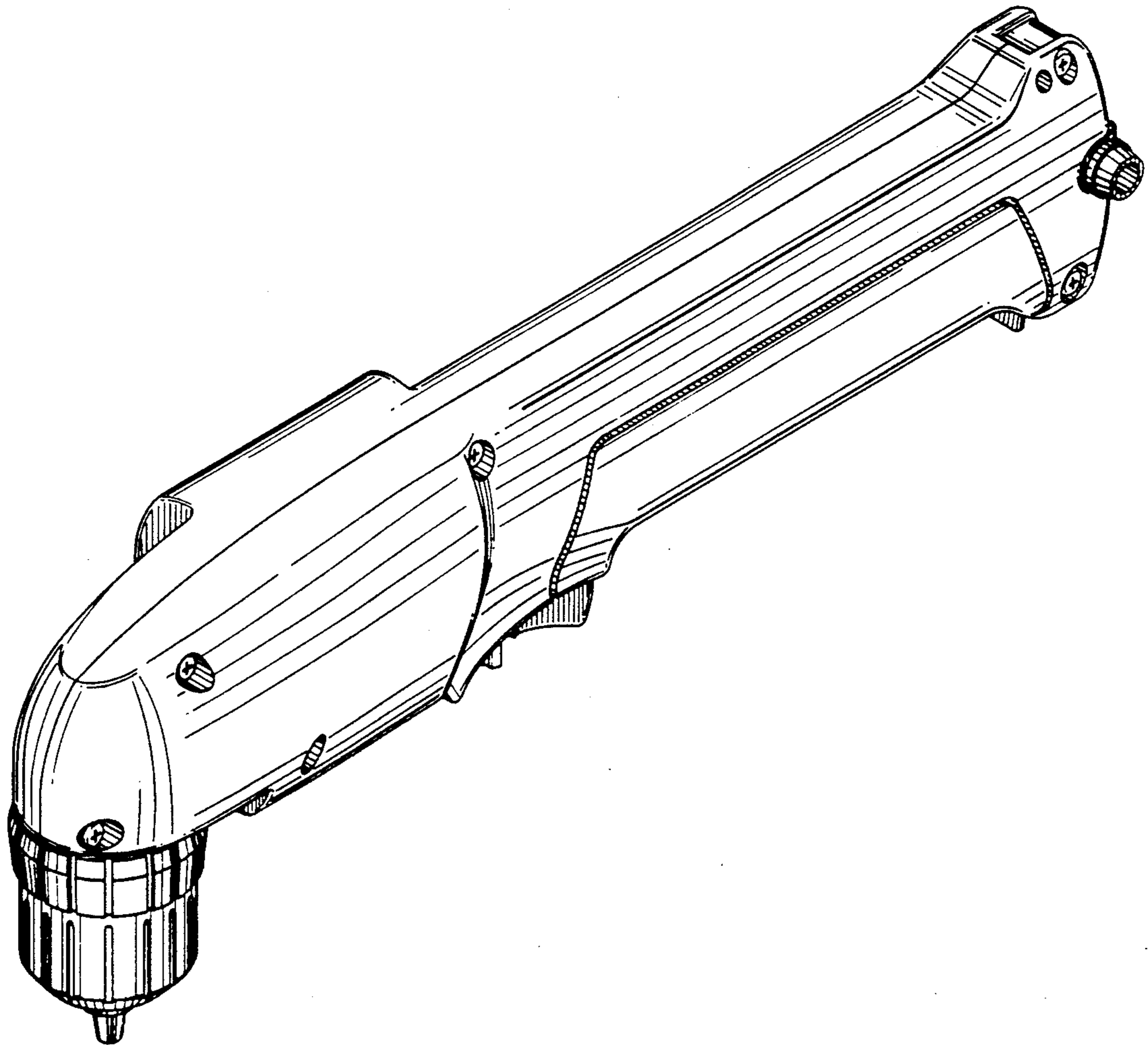

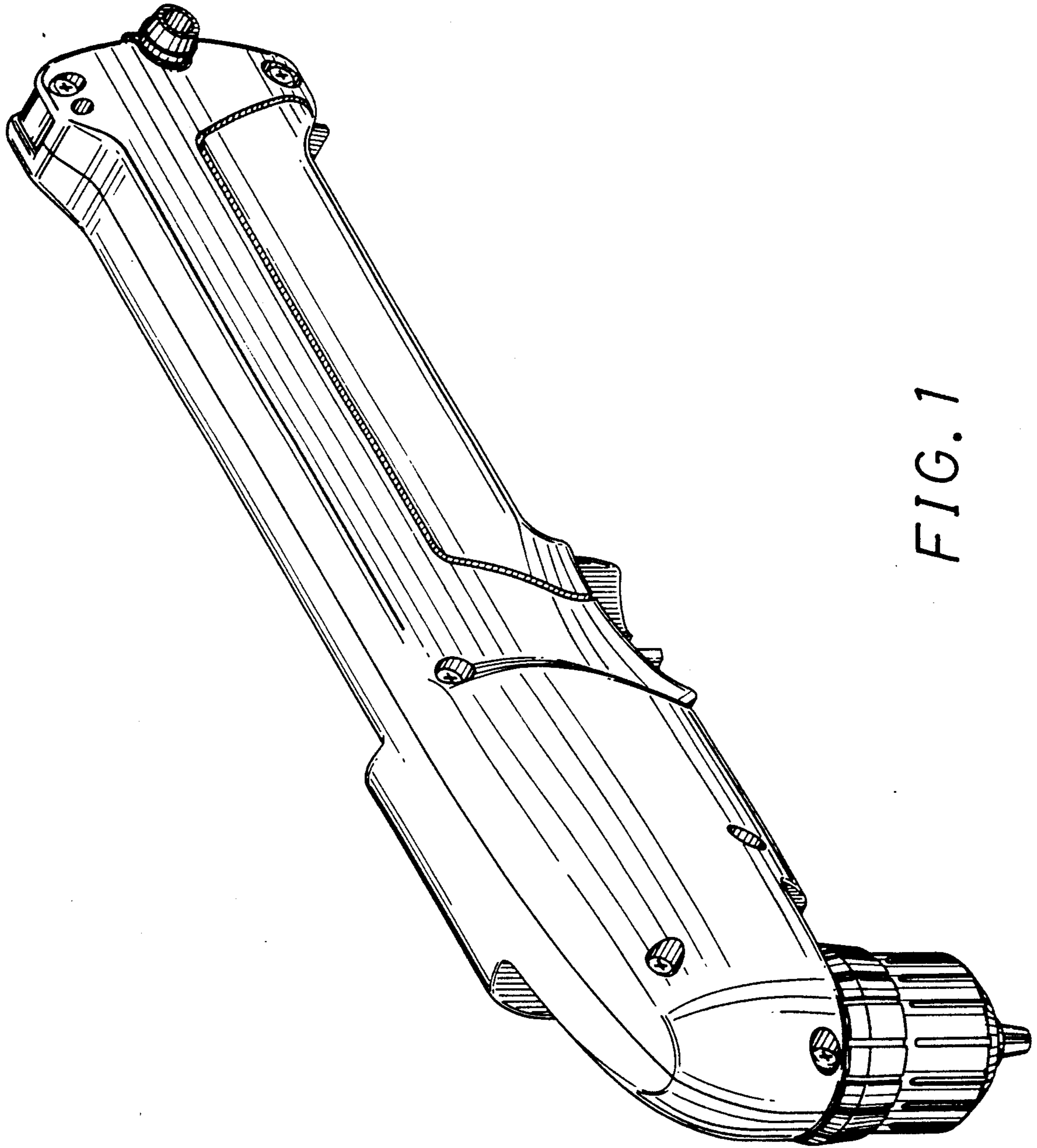

FIG. 1

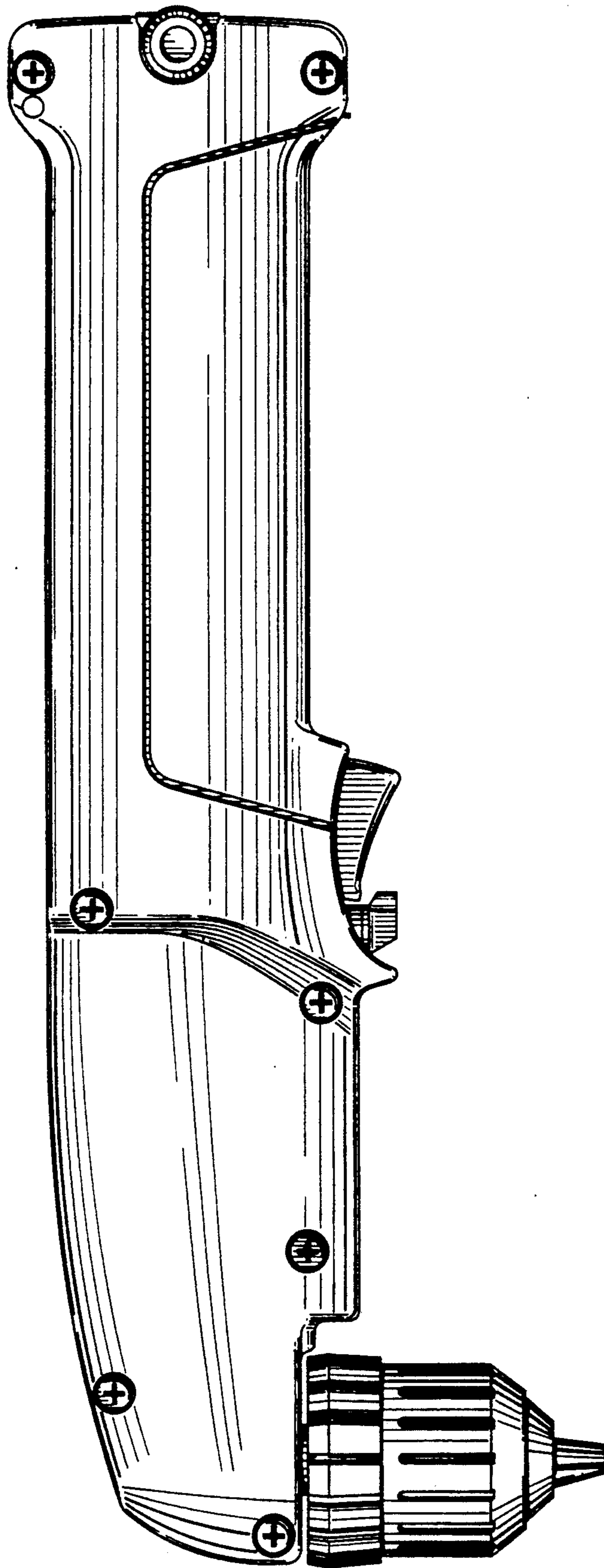

FIG. 2

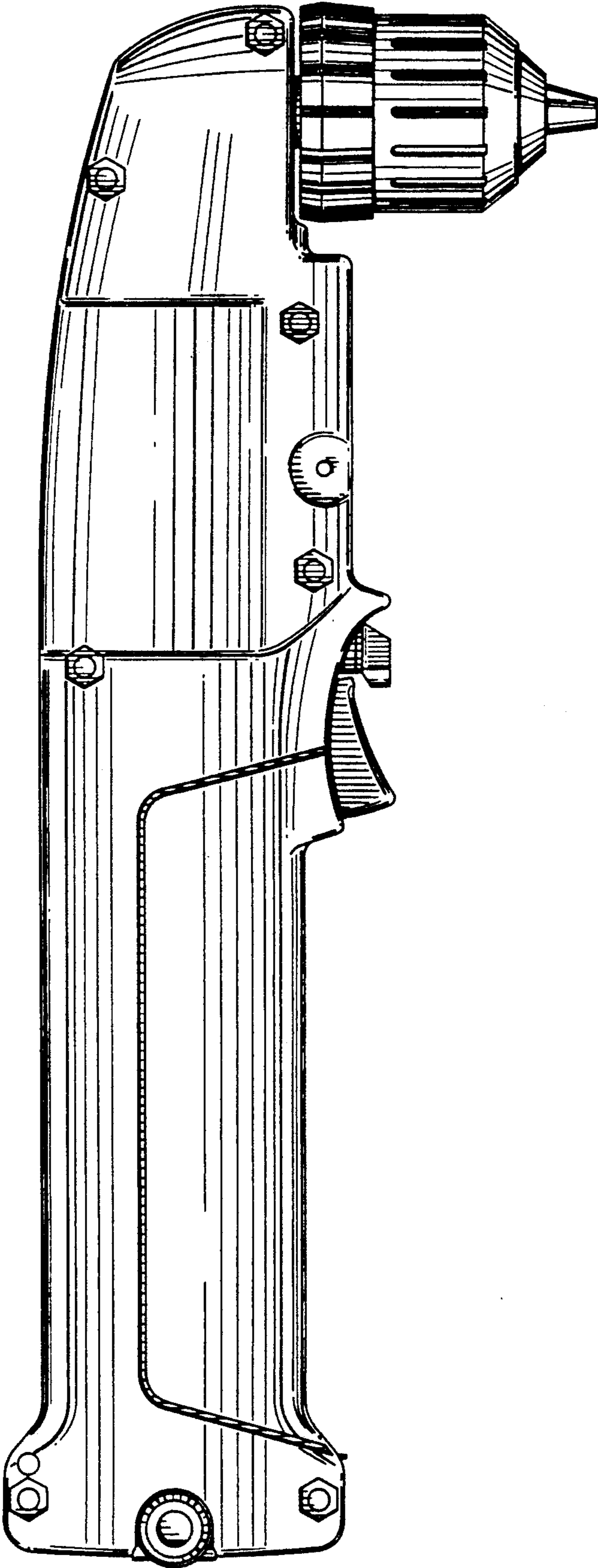

FIG. 3

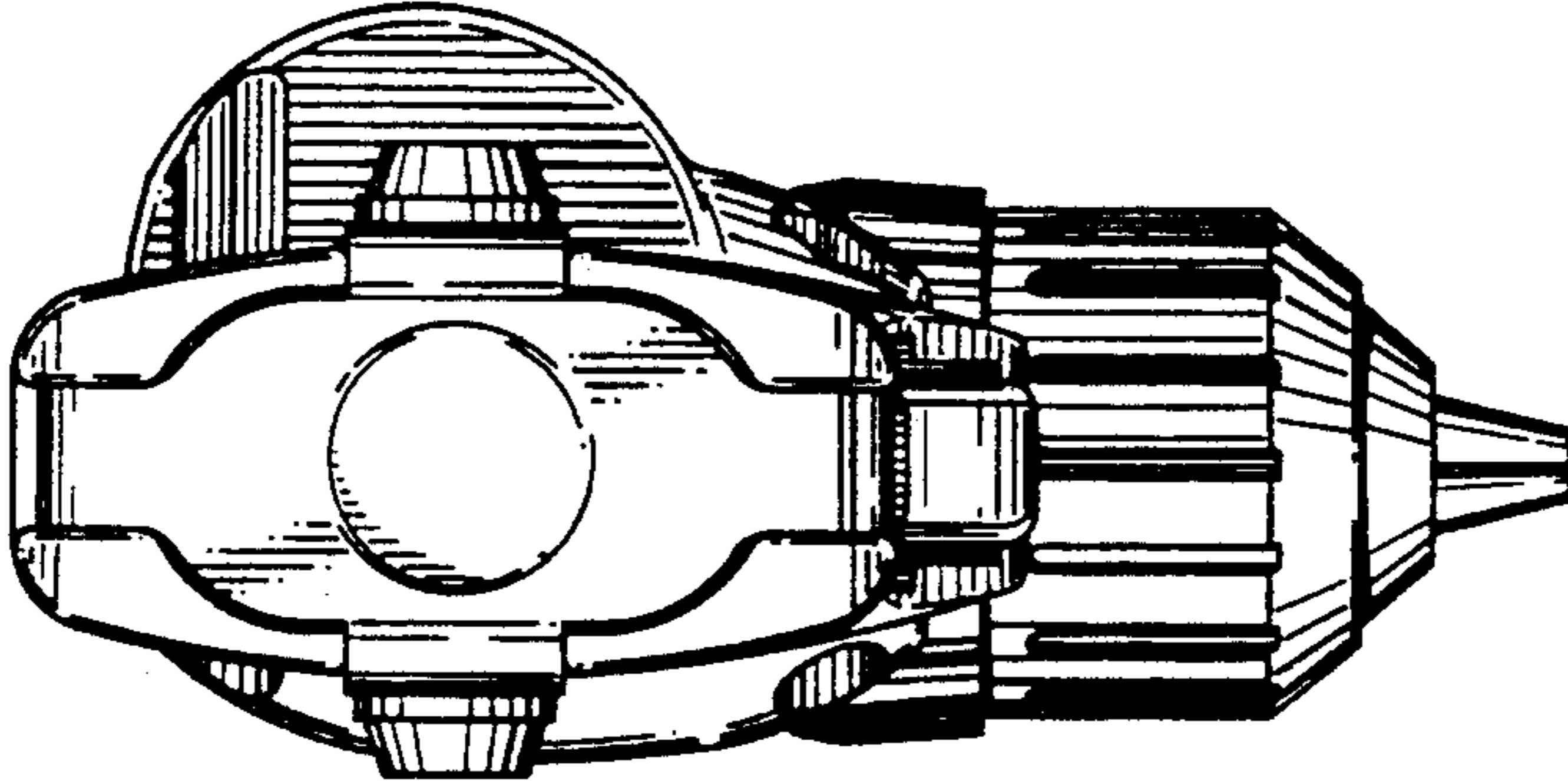

FIG. 5

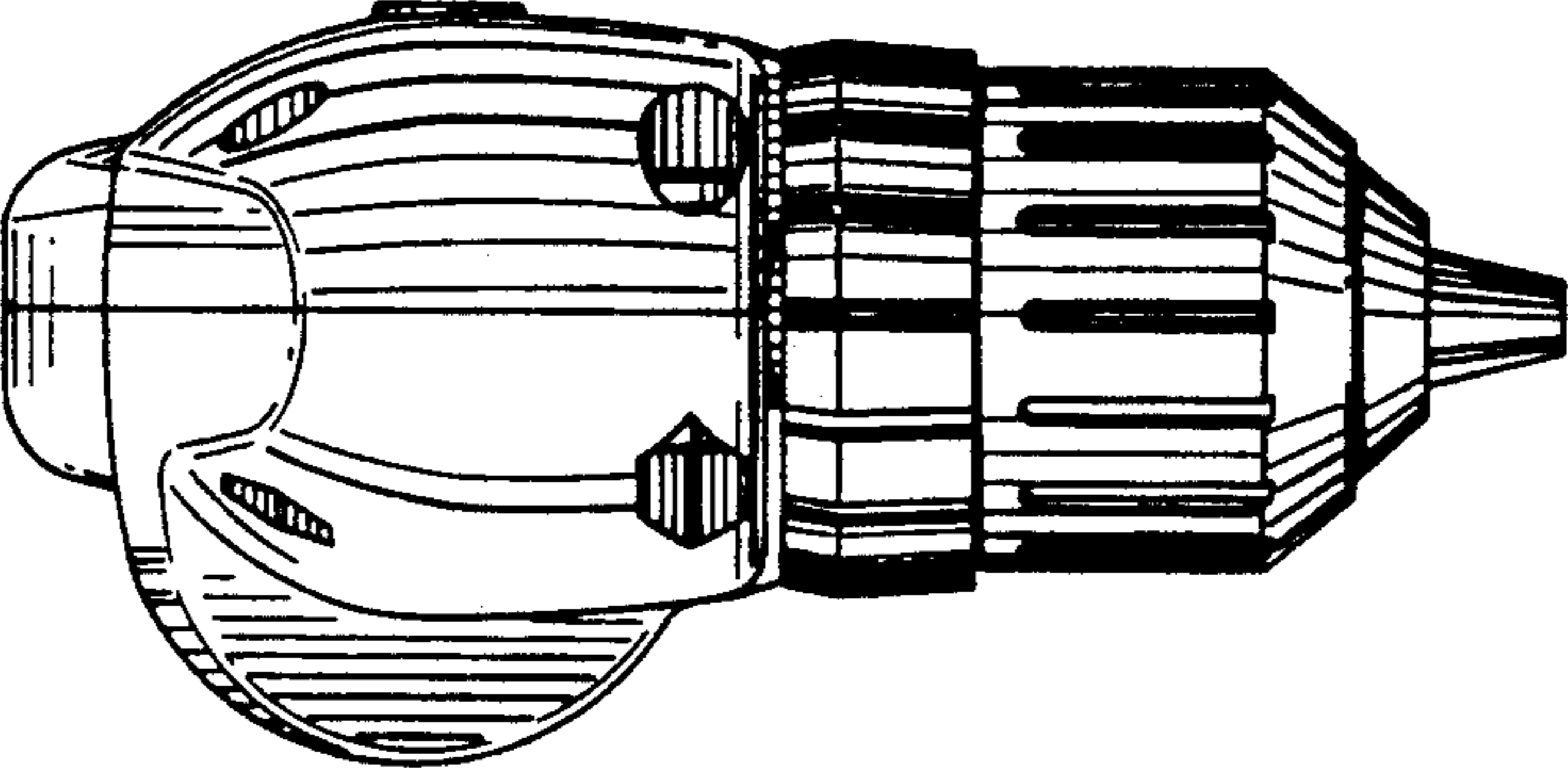

FIG. 4

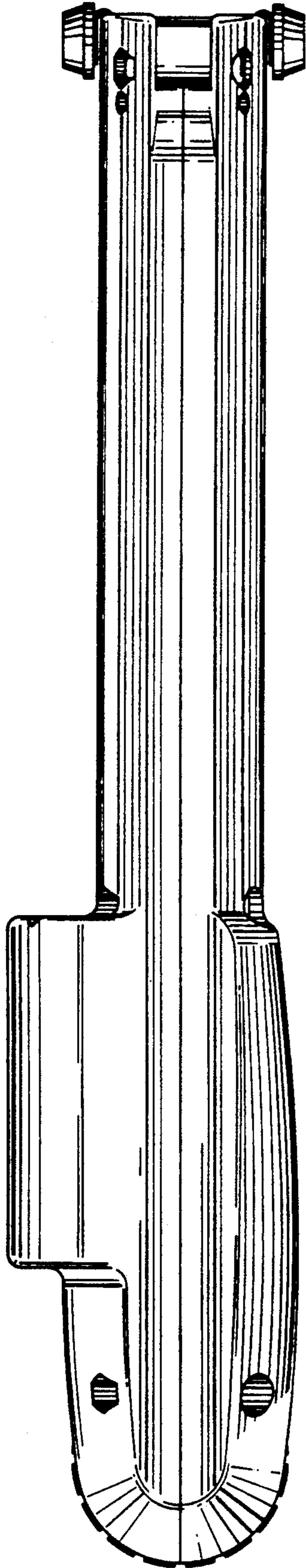

FIG. 6

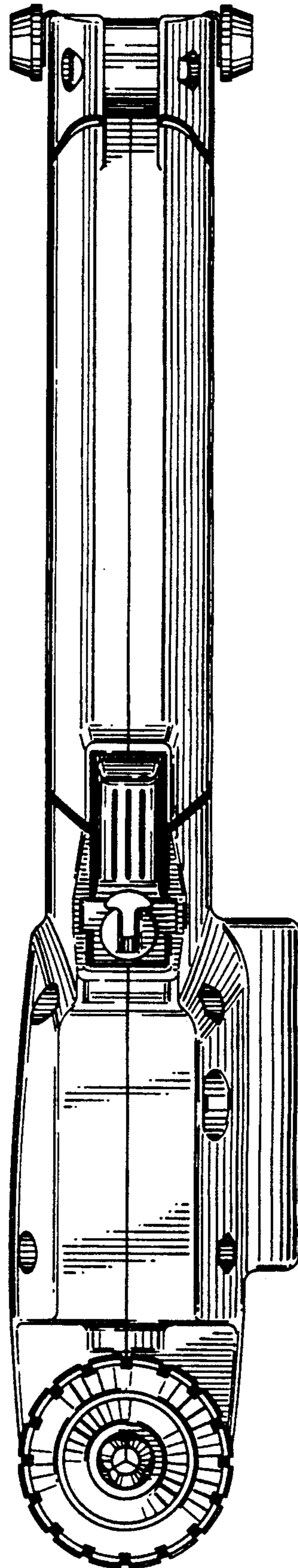

FIG. 7