



US00D323955S

United States Patent [19]

[11] Patent Number: **Des. 323,955**

Rixen

[45] Date of Patent: **** Feb. 18, 1992**

[54] **ELECTRICALLY OPERATED FOOD MIXER OR SIMILAR ARTICLE**

3,117,769 1/1964 Spingler 366/129
3,333,830 8/1967 Spingler et al. 366/129

[75] Inventor: **Edgar Rixen**, Solingen, Fed. Rep. of Germany

FOREIGN PATENT DOCUMENTS

839192 5/1952 Fed. Rep. of Germany 366/129

[73] Assignee: **Robert Krups Stiftung & Co. KG**, Solingen, Fed. Rep. of Germany

OTHER PUBLICATIONS

Krups 86/87 Catalog, Mailroom Date 12-14-87, p. 17, 3rd. Panel down on left #366/High Speed Cutting Rod with Splashguard.

[**] Term: **14 Years**

Primary Examiner—Winifred E. Herrmann
Attorney, Agent, or Firm—Peter K. Kontler

[21] Appl. No.: **275,262**

[22] Filed: **Nov. 22, 1988**

[30] Foreign Application Priority Data

May 26, 1988 [DE] Fed. Rep. of Germany 9858

[52] U.S. Cl. **D7/376; D7/379; D7/688**

[58] Field of Search D8/107, 303, 61, 68; D7/682, 372, 376, 379, 380, 386, 412, 646, 414, 415; 366/129, 279, 601

[57] CLAIM

The ornamental design for an electrically operated food mixer or similar article, as shown and described.

[56] References Cited

U.S. PATENT DOCUMENTS

D. 87,918 10/1932 Haney D7/682
D. 206,388 12/1966 Clemente D7/414
1,766,171 6/1930 Hetherington D7/380 X

DESCRIPTION

FIG. 1 is a top plan view of an electrically operated food mixer or similar article showing my new design; FIG. 2 is a first side elevational view thereof; FIG. 3 is a bottom plan view thereof; FIG. 4 is a second side elevational view thereof; FIG. 5 is an enlarged front elevational view thereof; FIG. 6 is an enlarged rear elevational view thereof; and FIG. 7 is an enlarged perspective view thereof.

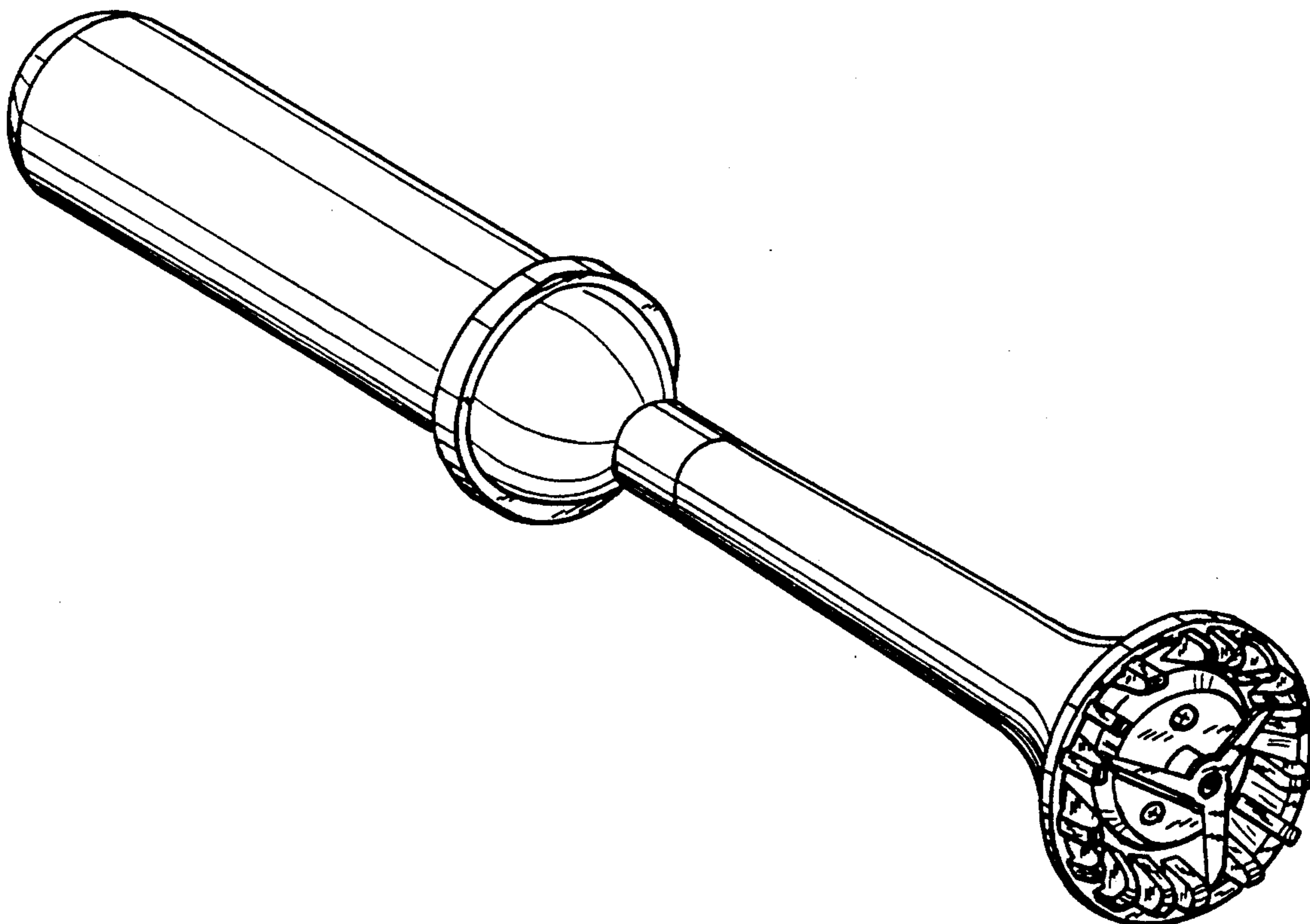

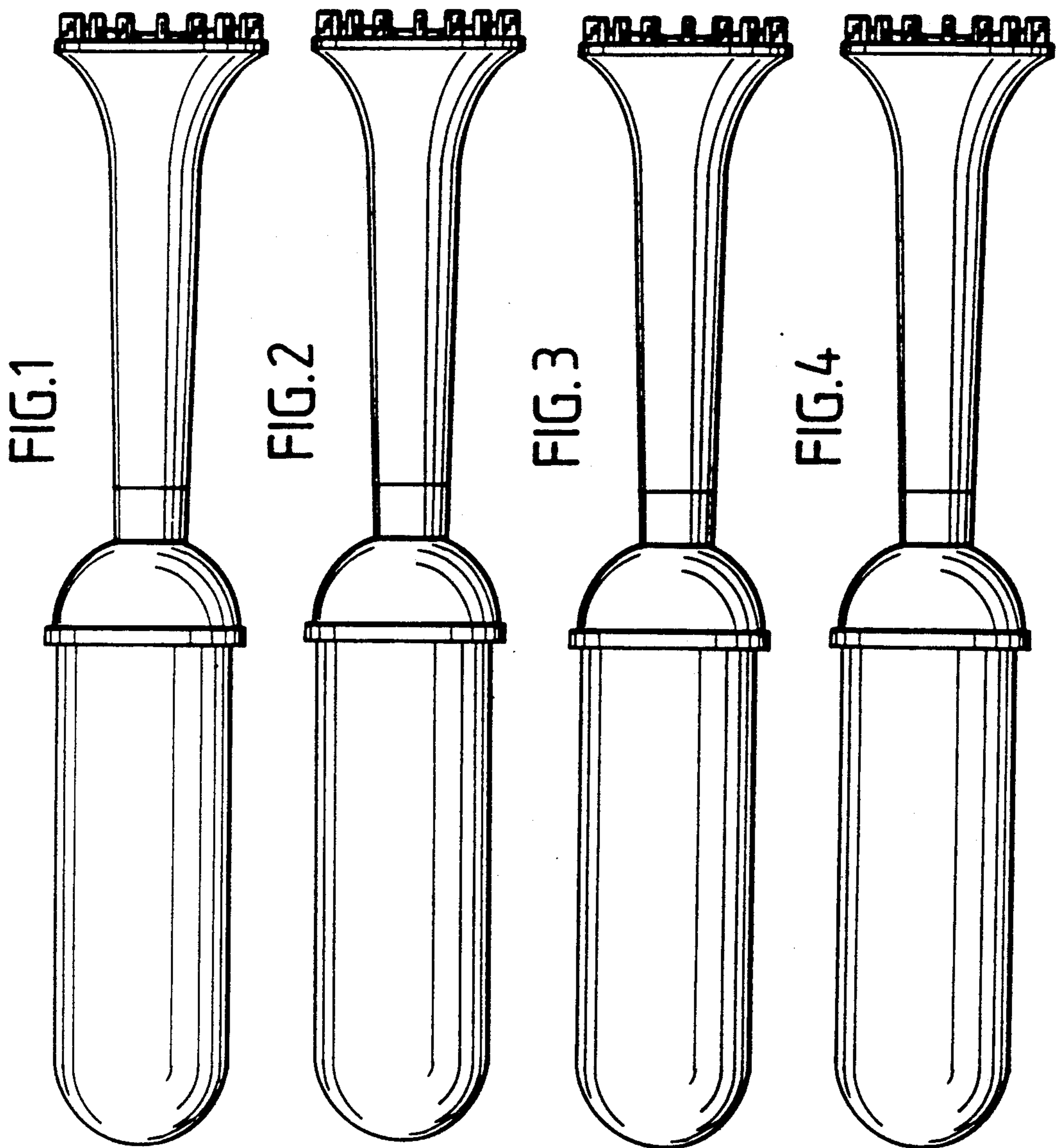

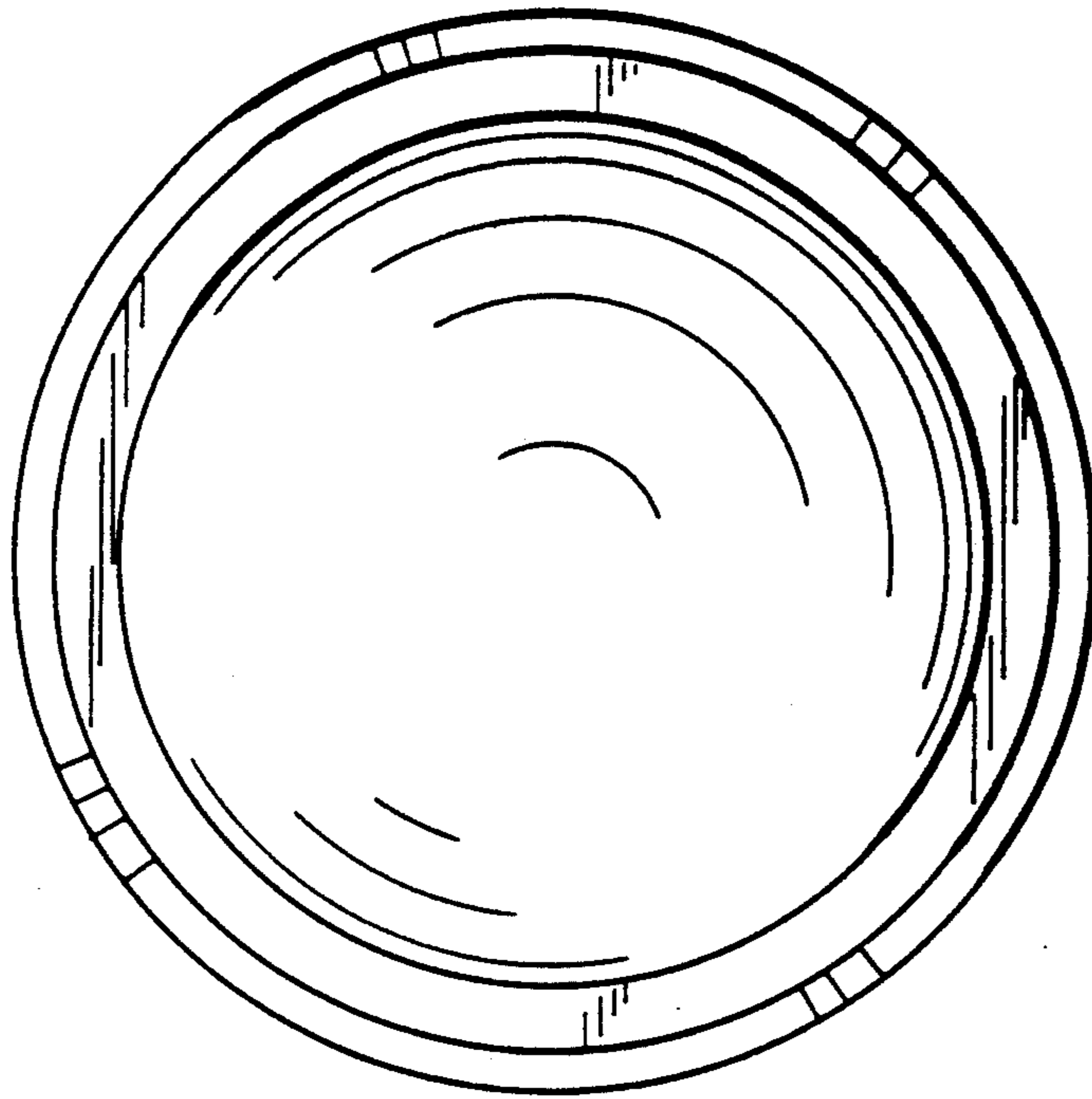

FIG. 6

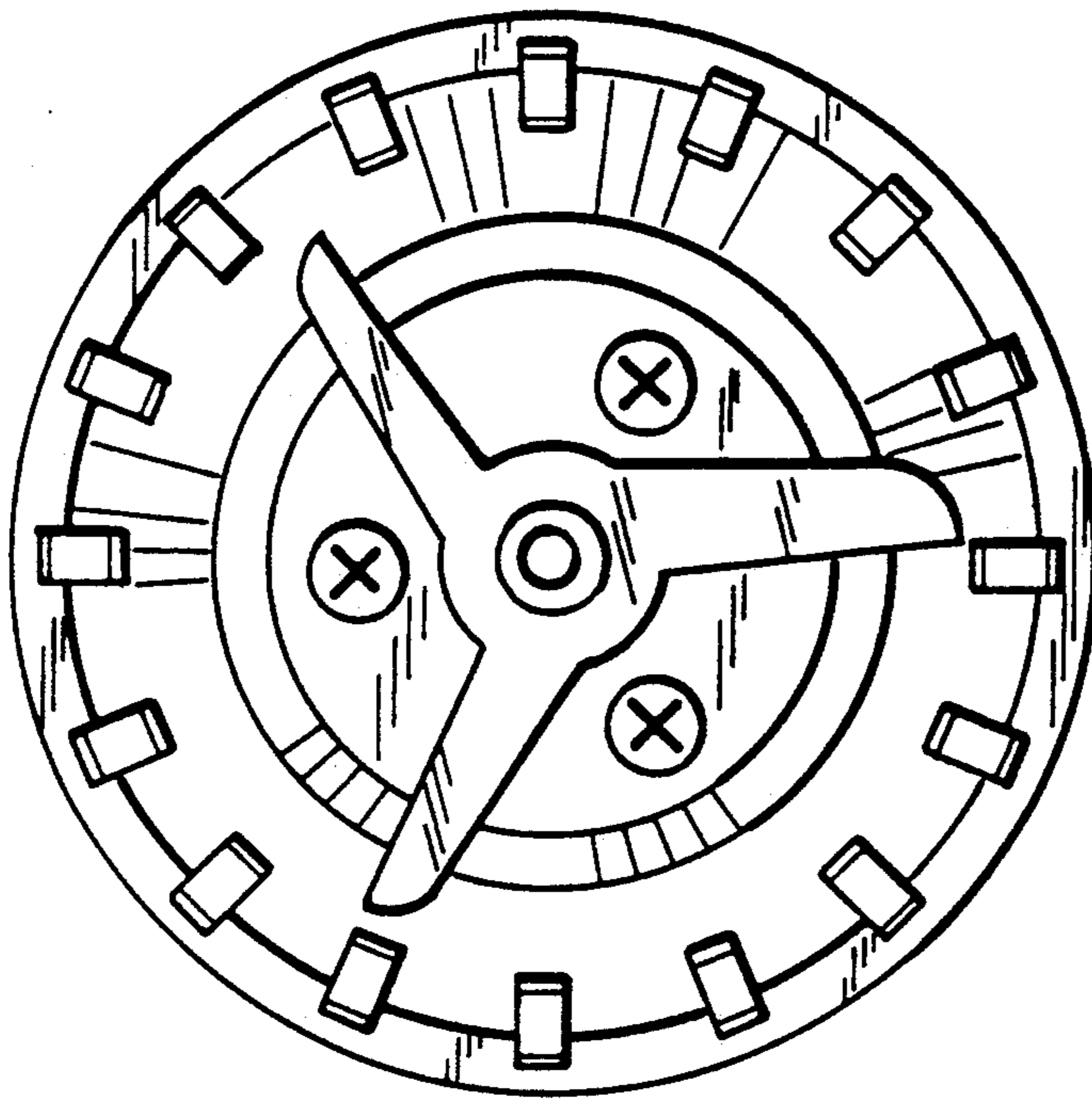

FIG. 5

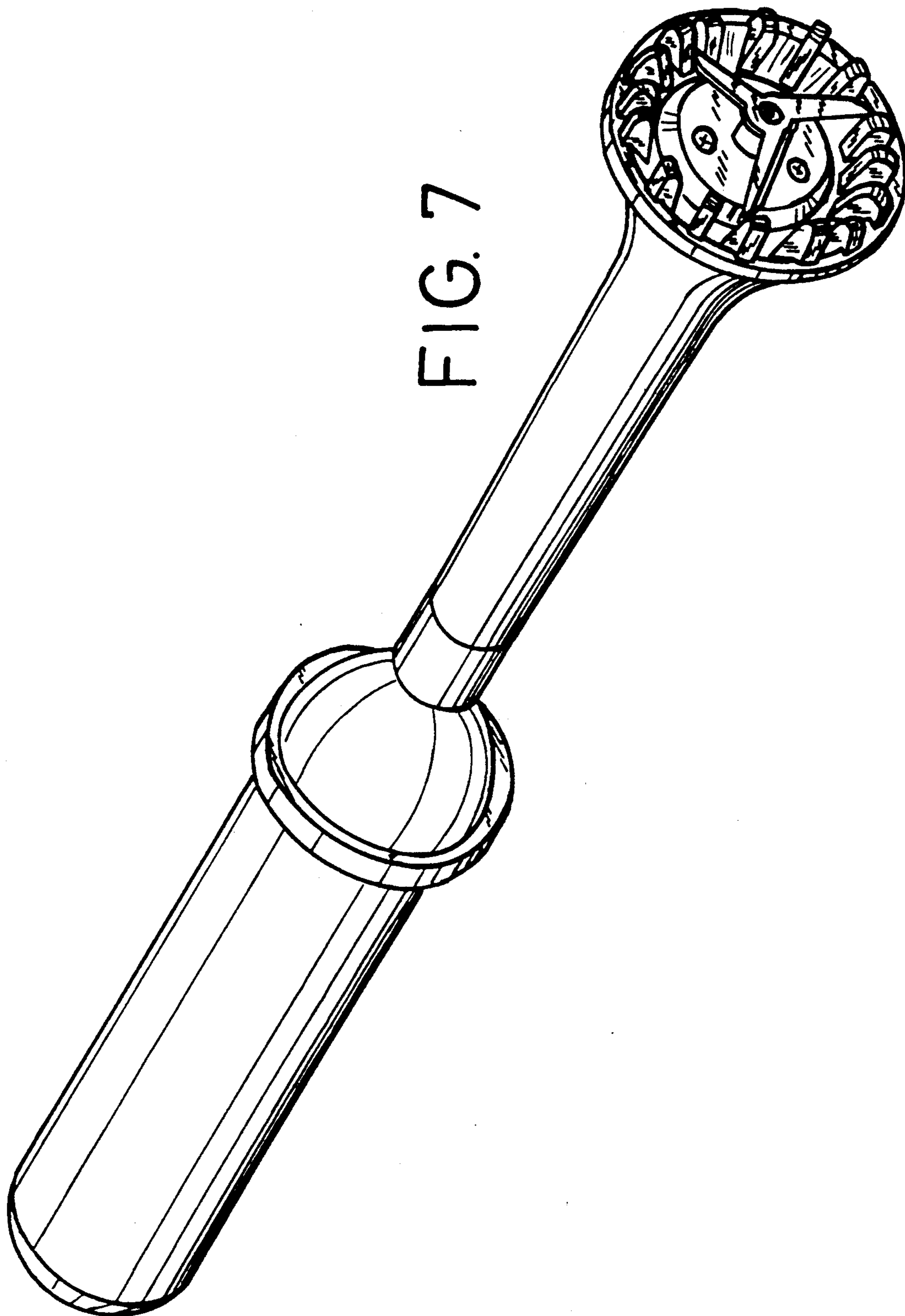

FIG. 7