



US00D323932S

United States Patent [19]

[11] Patent Number: **Des. 323,932**

Hudgens

[45] Date of Patent: **** Feb. 18, 1992**

[54] **UTILITY CONSOLE FOR A TRUCK**

D. 304,263	10/1989	Mull	D3/40
3,561,589	2/1971	Larkin	224/42.11
4,300,709	11/1981	Page, Jr.	224/275
4,942,990	7/1990	White	224/273 X

[76] Inventor: **Ronald E. Hudgens**, Rte. 3, Box 158A, Lenoir City, Tenn. 37771

[**] Term: **14 Years**

Primary Examiner—A. Hugo Word
Assistant Examiner—M. N. Pandozzi
Attorney, Agent, or Firm—Pitts and Brittian

[21] Appl. No.: **230,990**

[57] **CLAIM**

[22] Filed: **Aug. 11, 1988**

The ornamental design for a utility console for a truck, as shown and described.

[52] U.S. Cl. **D3/40**

[58] Field of Search D3/39, 35, 40, 74, 73, D3/99, 30.1; D12/155, 156, 157; D7/553; 220/427, DIG. 13; 224/276, 275, 277, 273, 42.42, 42.45 R, 42.39, 42.11; 40/904; 296/37.1, 37.8, 70; 211/88, 71, 74, 69.5, 40; 108/12, 43, 44, 46, 45

DESCRIPTION

FIG. 1 is a perspective view of a utility console for a truck showing my new design wherein the lid is in partially open position;
FIG. 2 is a left side elevational view thereof;
FIG. 3 is a right side elevational view thereof;
FIG. 4 is a top plan view thereof;
FIG. 5 is a bottom plan view thereof;
FIG. 6 is a front elevational view thereof; and
FIG. 7 is a rear elevational view thereof.

[56] **References Cited**

U.S. PATENT DOCUMENTS

D. 258,324	2/1981	Rader	D3/39
D. 268,072	3/1983	Boggs	D7/553 X

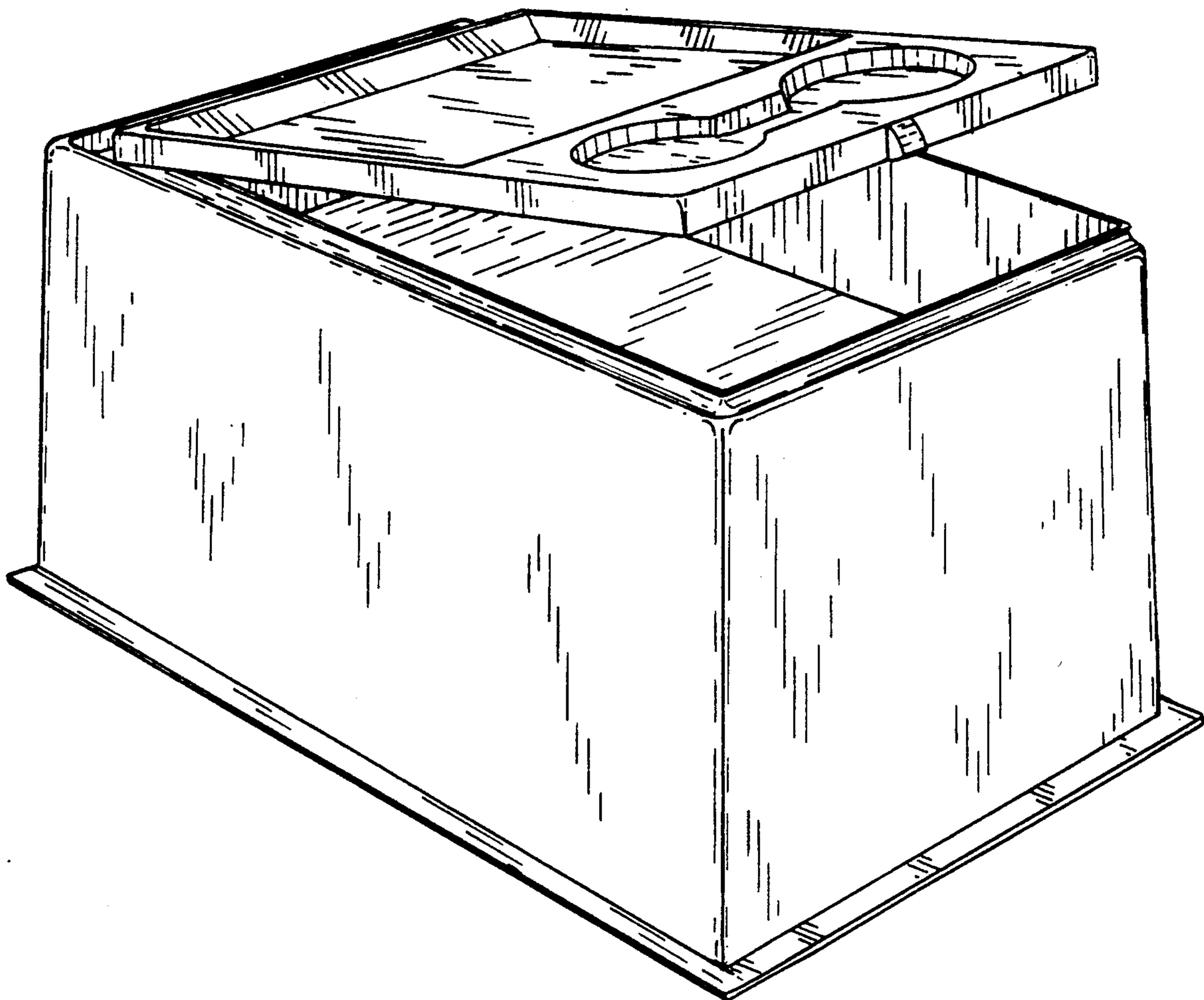

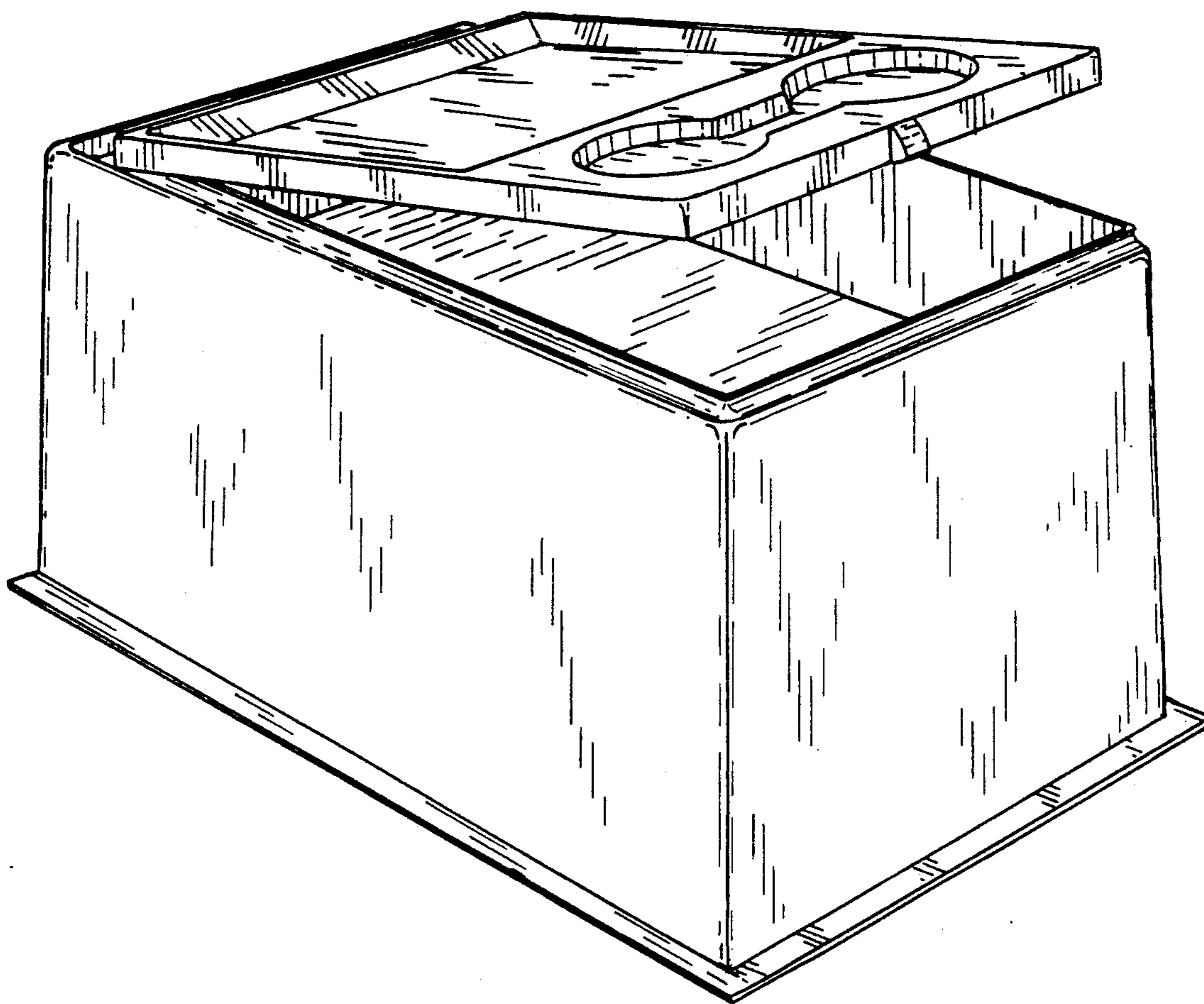

FIG. 1

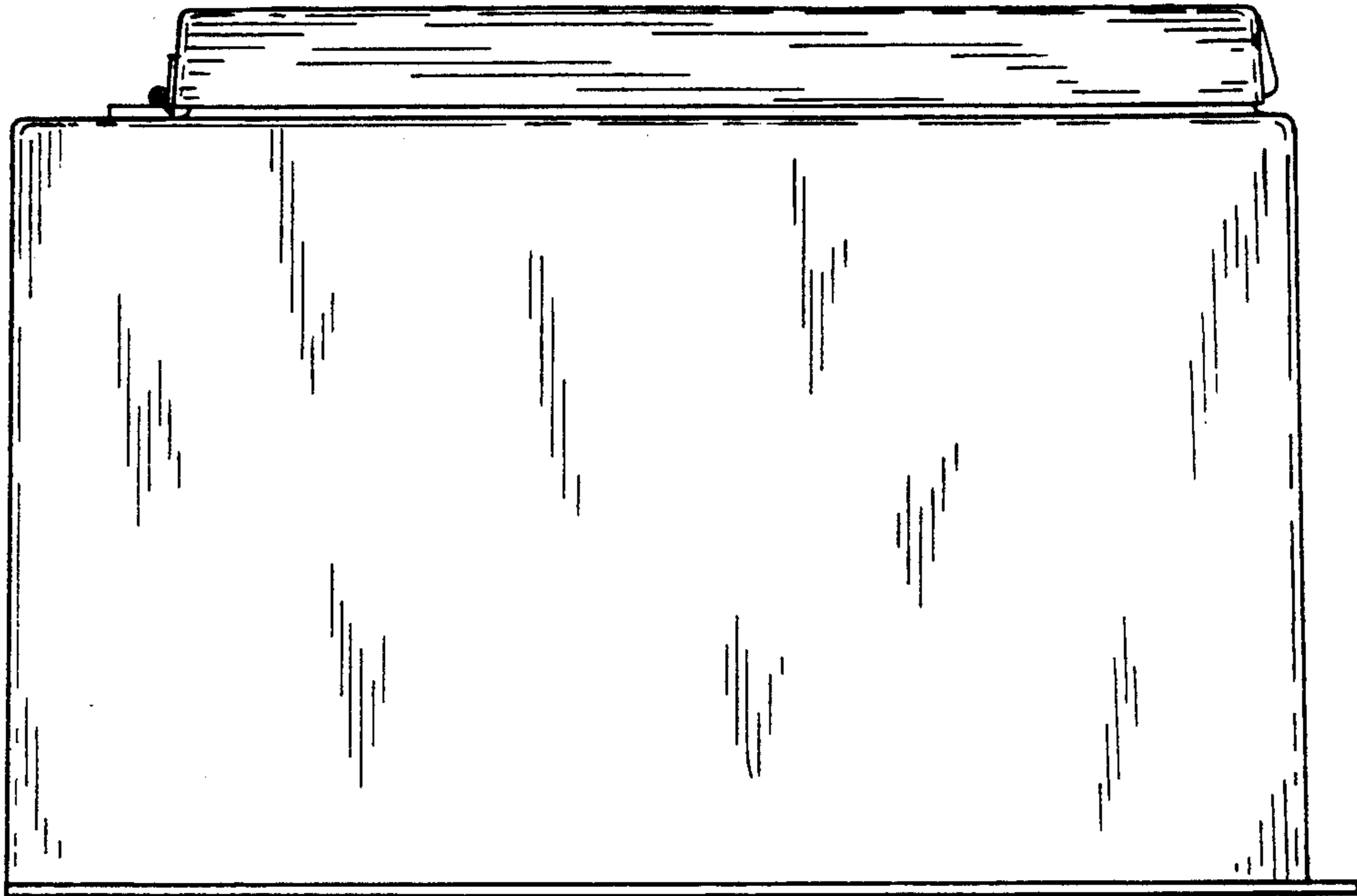

FIG. 2

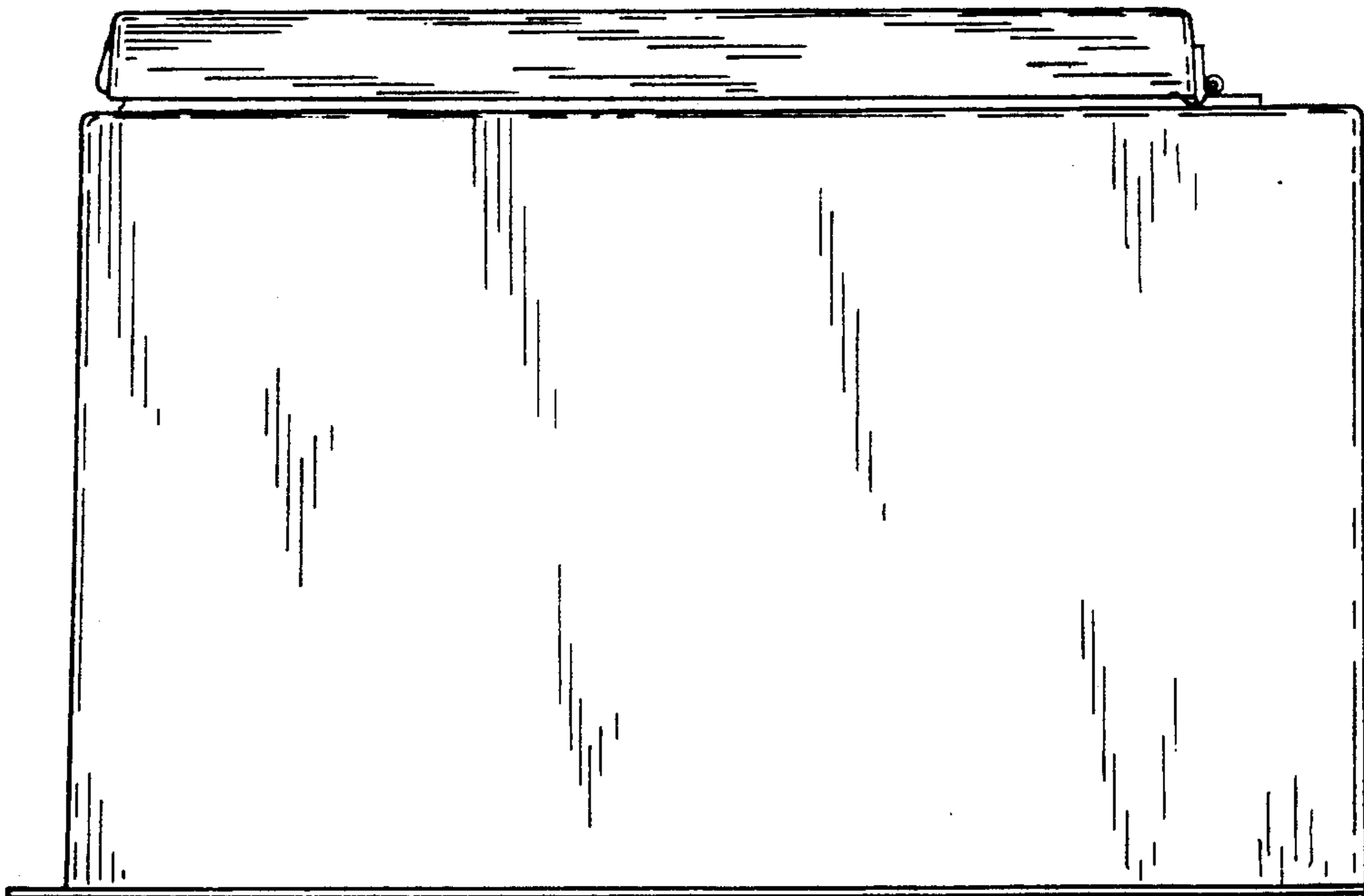

FIG. 3

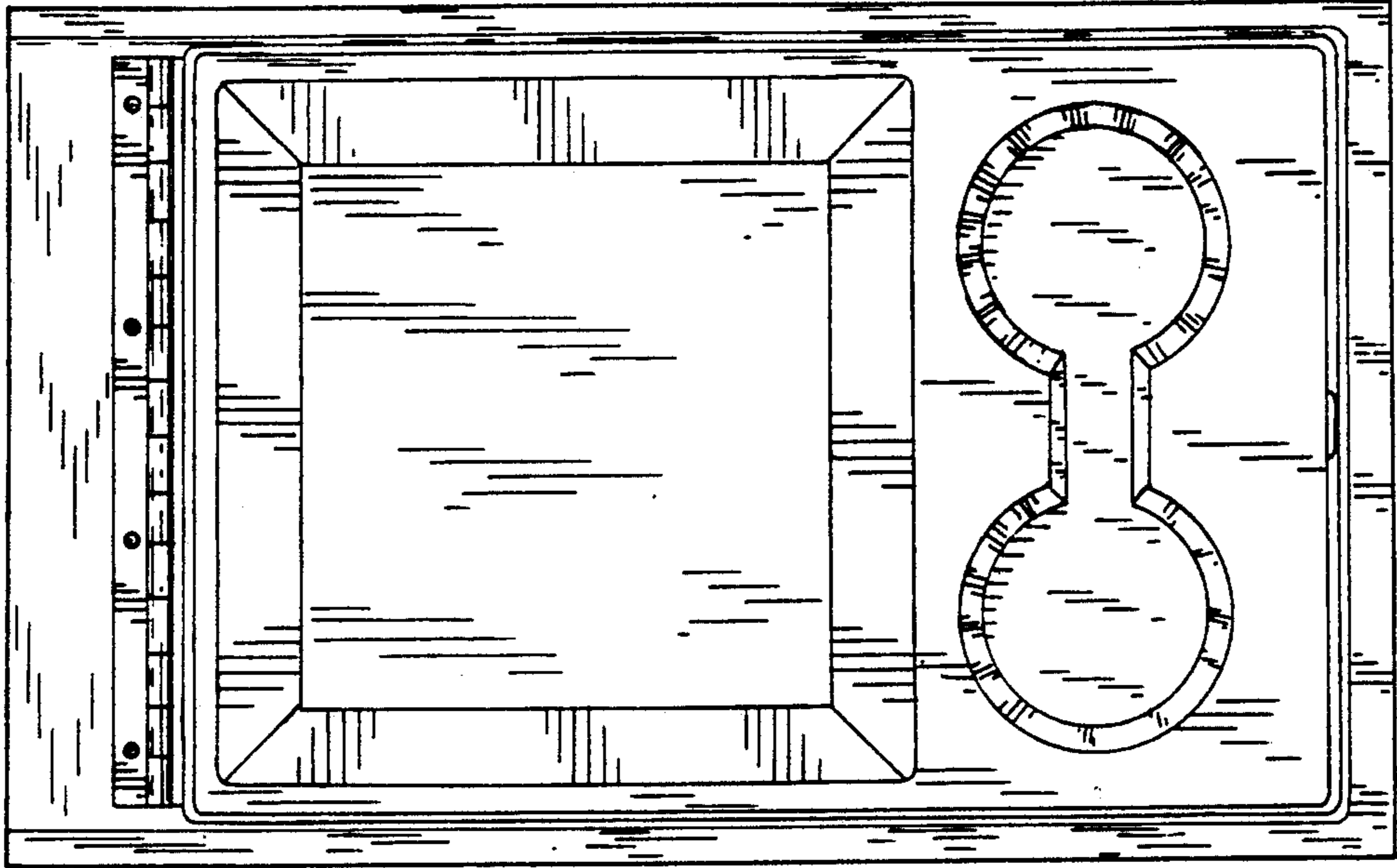

FIG. 4

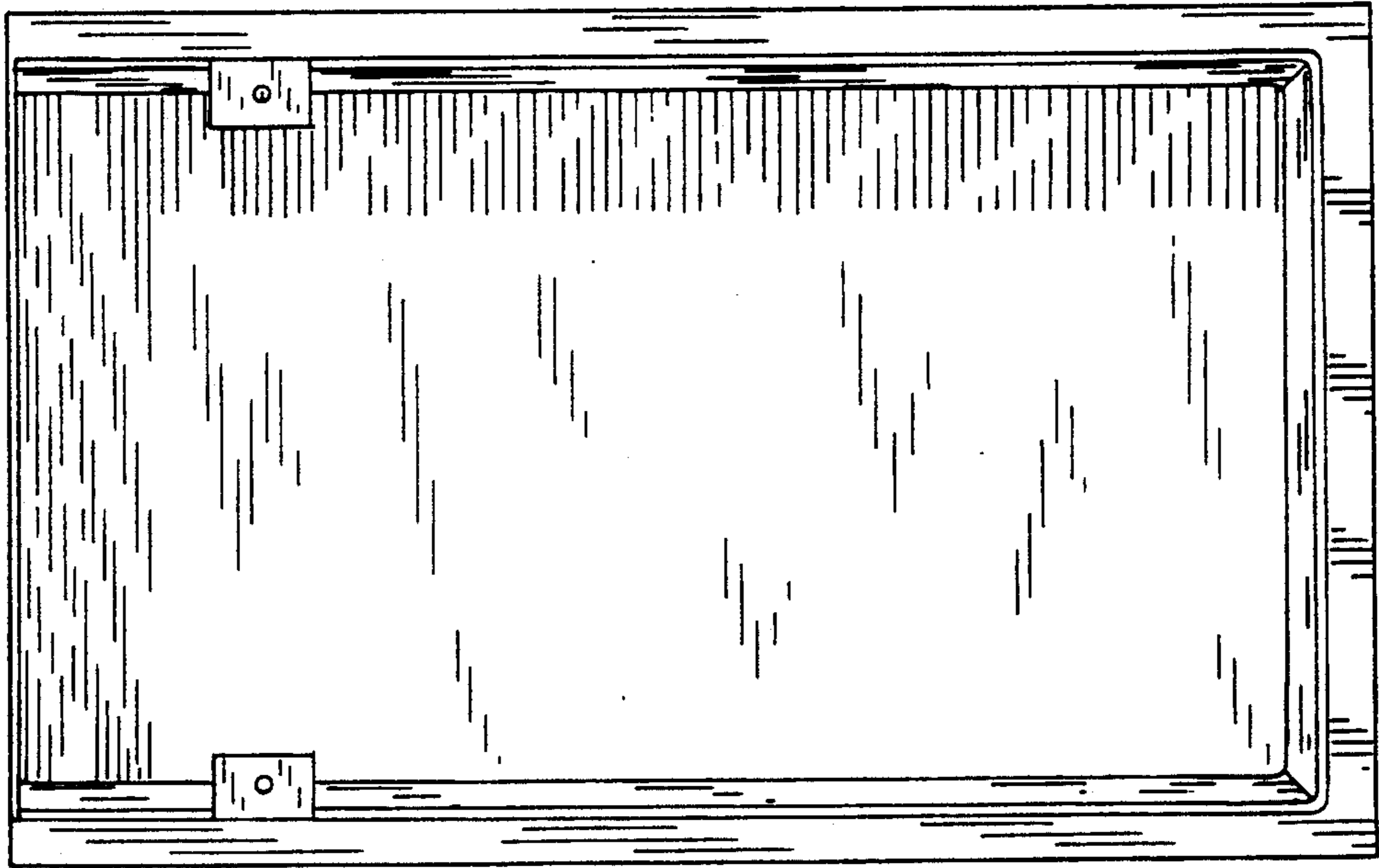

FIG. 5

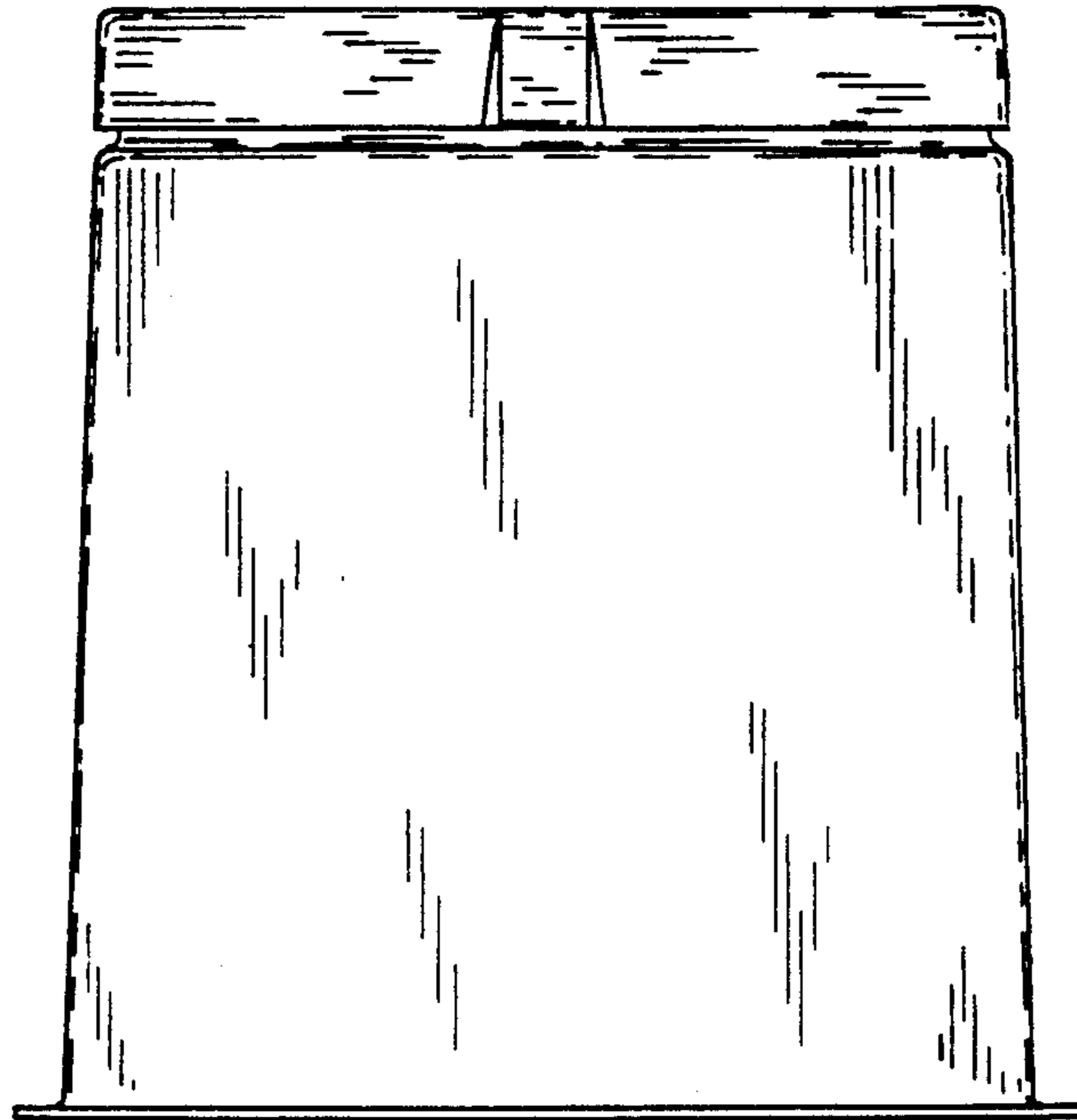

FIG. 6

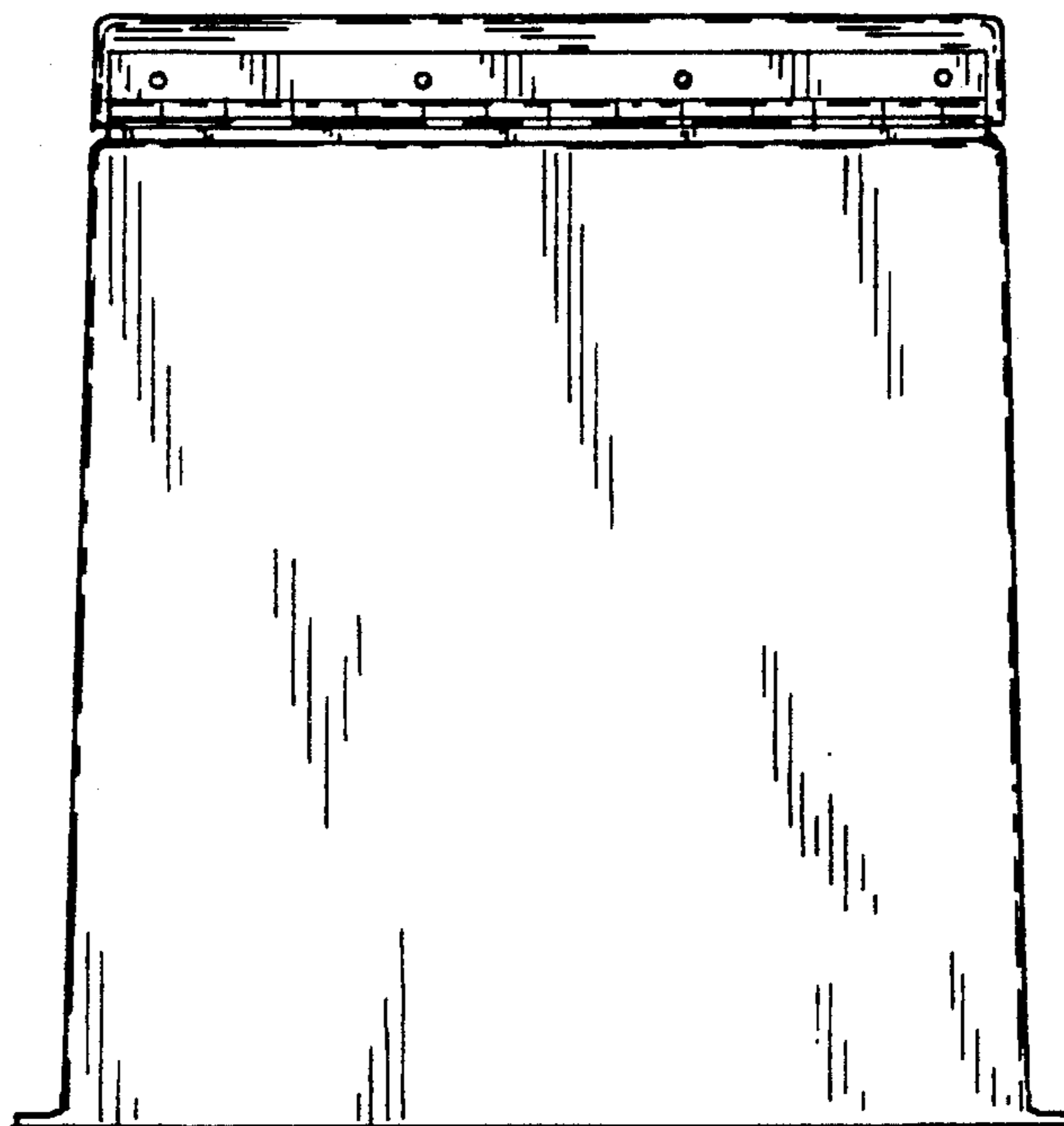

FIG. 7