



US00D323899S

# United States Patent [19]

[11] Patent Number: **Des. 323,899**

**LaPointe**

[45] Date of Patent: **\*\* Feb. 11, 1992**

## [54] VEHICLE HEADLIGHT

[75] Inventor: **Y. Anselme LaPointe**, St-Eli  
d'Orford, Canada

[73] Assignee: **Bombardier Inc.**, Canada

[\*\*] Term: **14 Years**

[21] Appl. No.: **436,678**

[22] Filed: **Nov. 15, 1989**

### [30] Foreign Application Priority Data

Jun. 6, 1989 [CA] Canada ..... 06-06-89-6

[52] U.S. Cl. .... **D26/28**

[58] Field of Search ..... **D26/28-36;**  
**362/61, 80, 81, 82, 83**

### [56] References Cited

#### U.S. PATENT DOCUMENTS

4,446,511 5/1984 Sands ..... 362/61 X  
4,481,563 11/1984 Snyder et al. .... 362/83 X

### OTHER PUBLICATIONS

Company catalogue of assignee, Bombardier Inc., showing old headlight design, published prior to Nov. 15, 1988.

*Primary Examiner*—Susan J. Lucas

*Attorney, Agent, or Firm*—Larson and Taylor

### [57] CLAIM

The ornamental design for a vehicle headlight, as shown and described.

### DESCRIPTION

FIG. 1 is a front perspective view of a vehicle headlight embodying my design;

FIG. 2 is a top plan view thereof;

FIG. 3 is a front elevational view thereof;

FIG. 4 is an underneath plan view thereof;

FIG. 5 is a rear elevational view thereof; and

FIGS. 6 and 7 are side elevational views thereof from opposite sides.

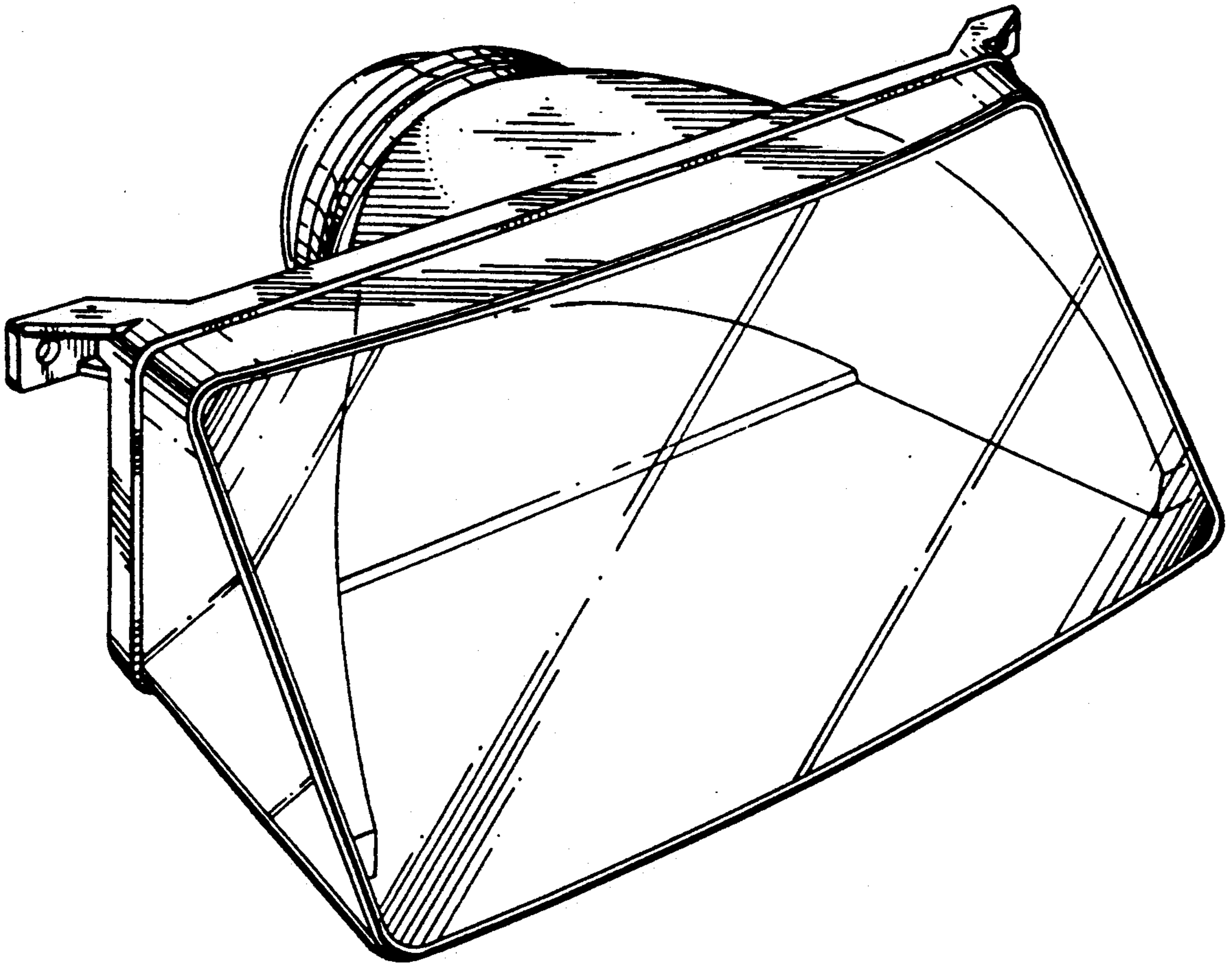

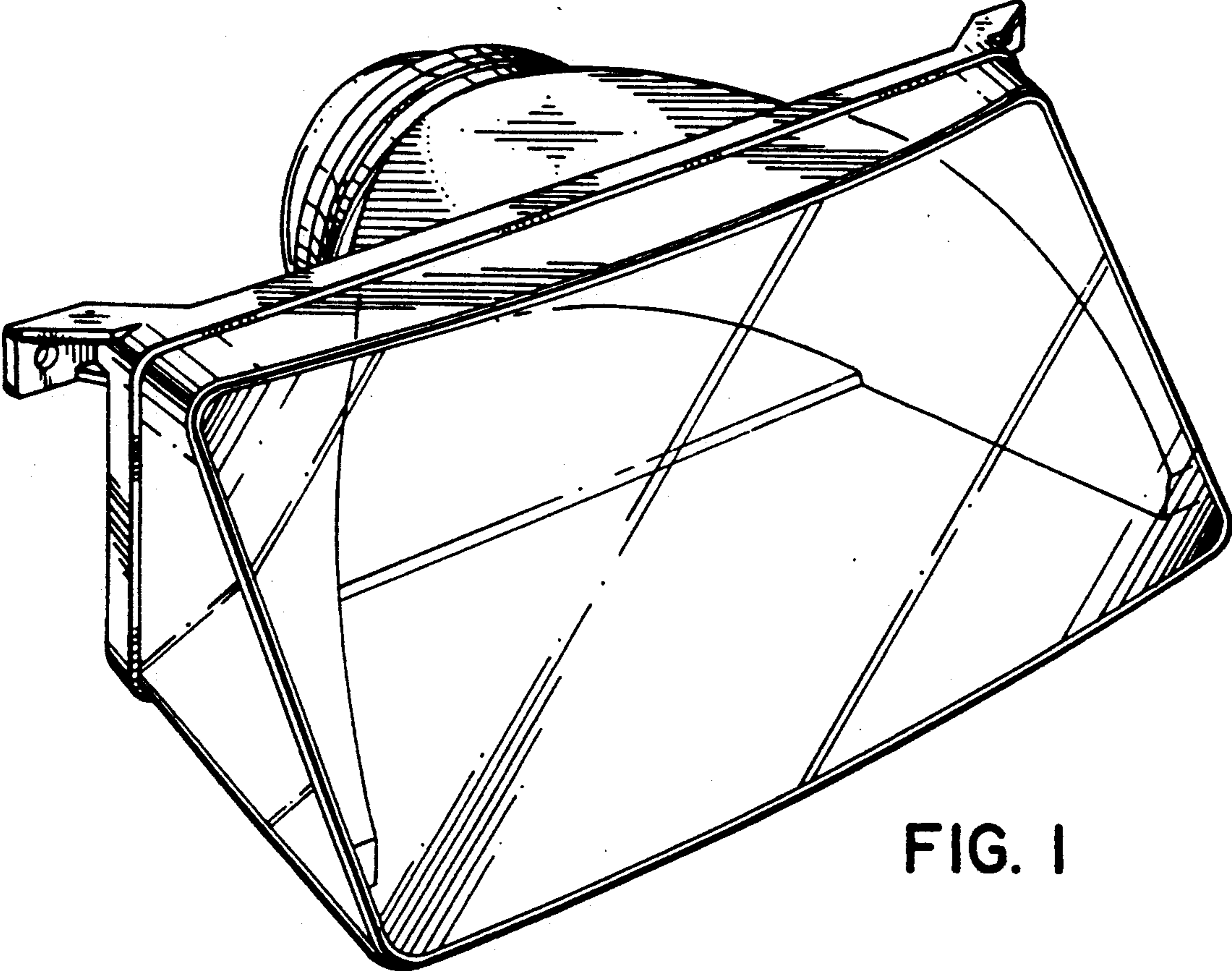

FIG. 1

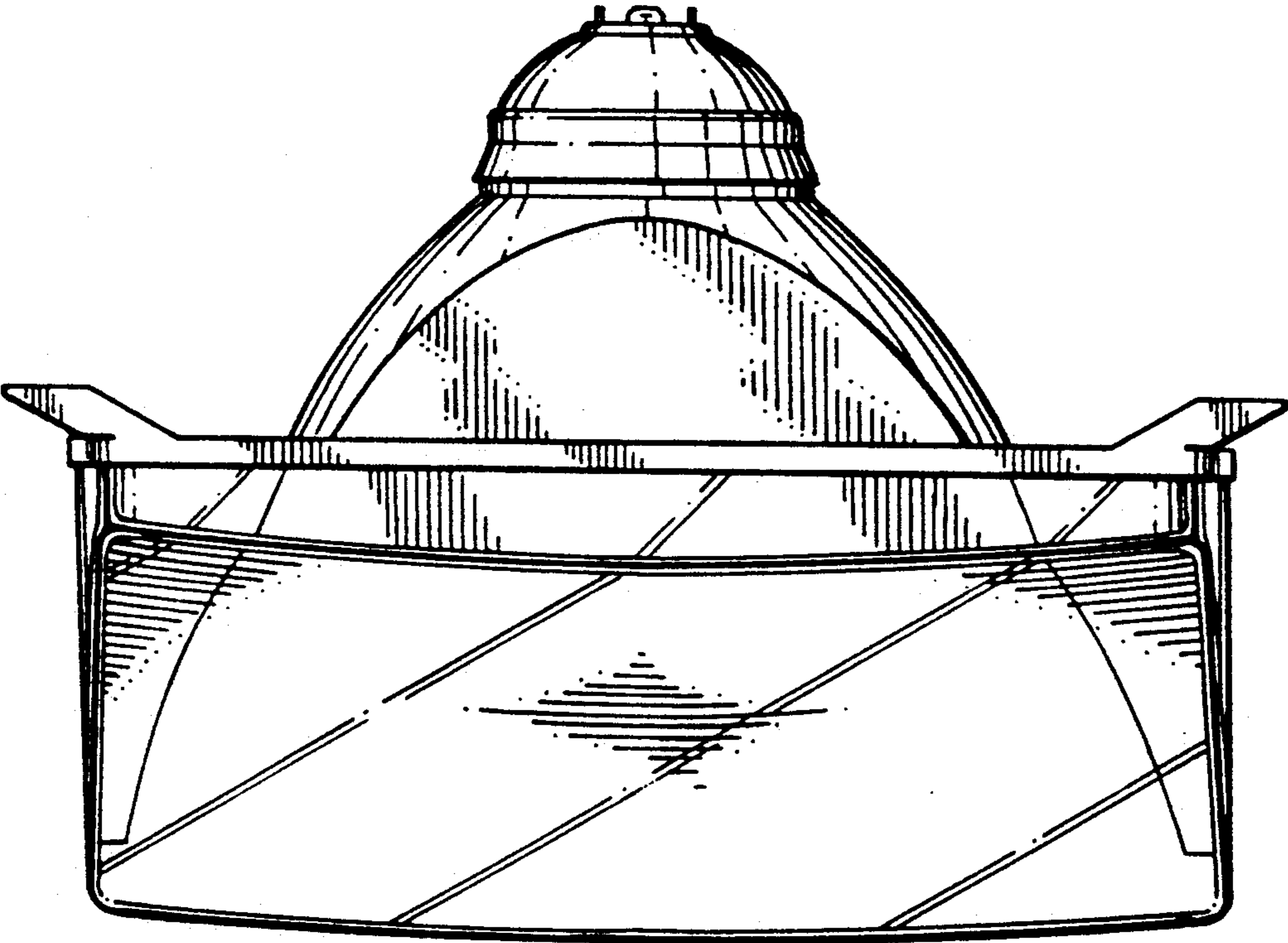

FIG. 2

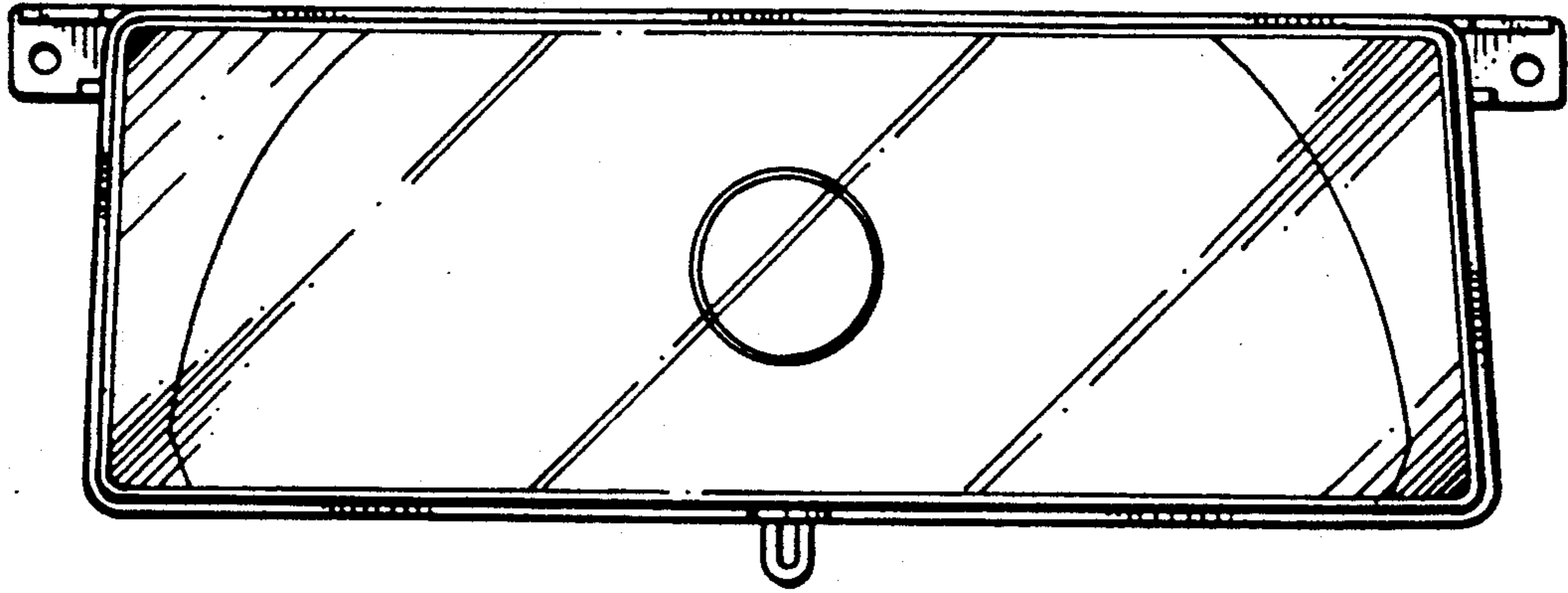

FIG. 3

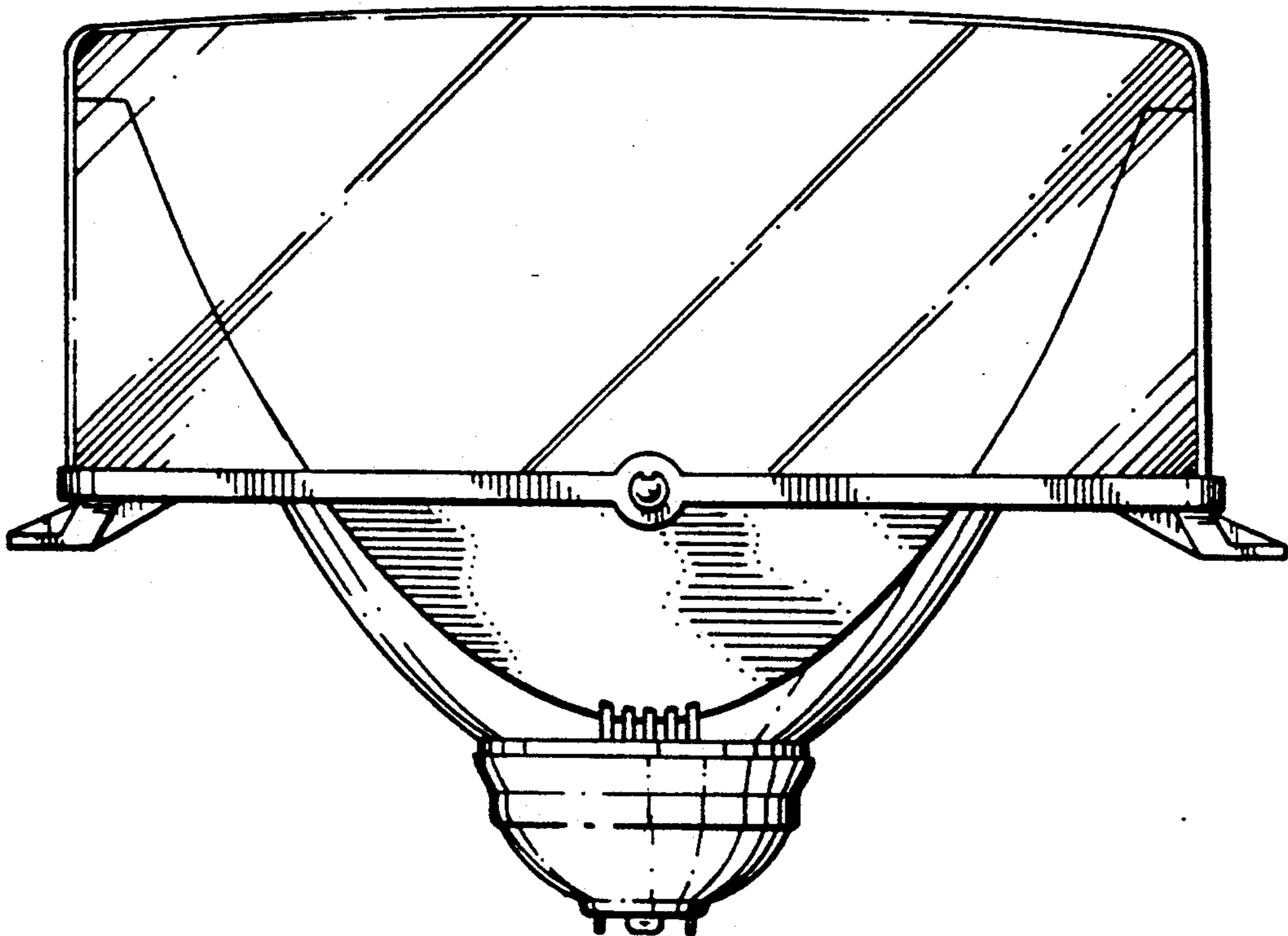

FIG. 4

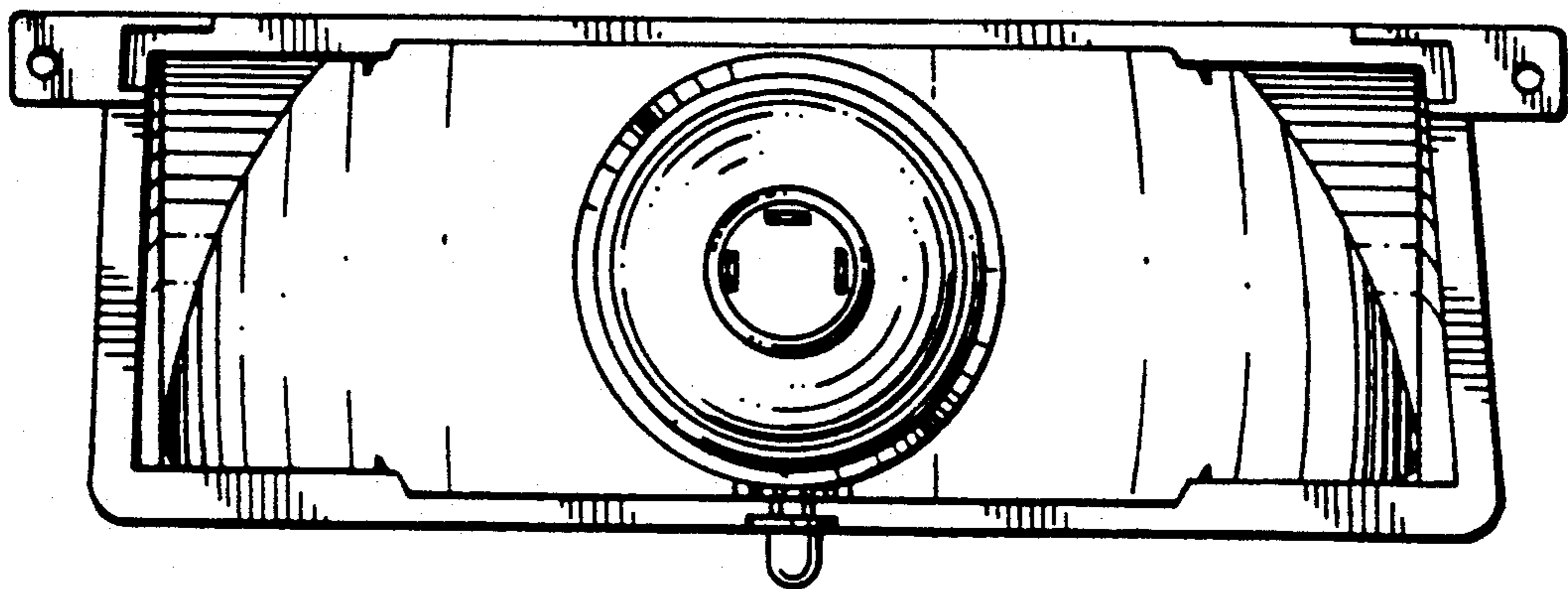

FIG. 5

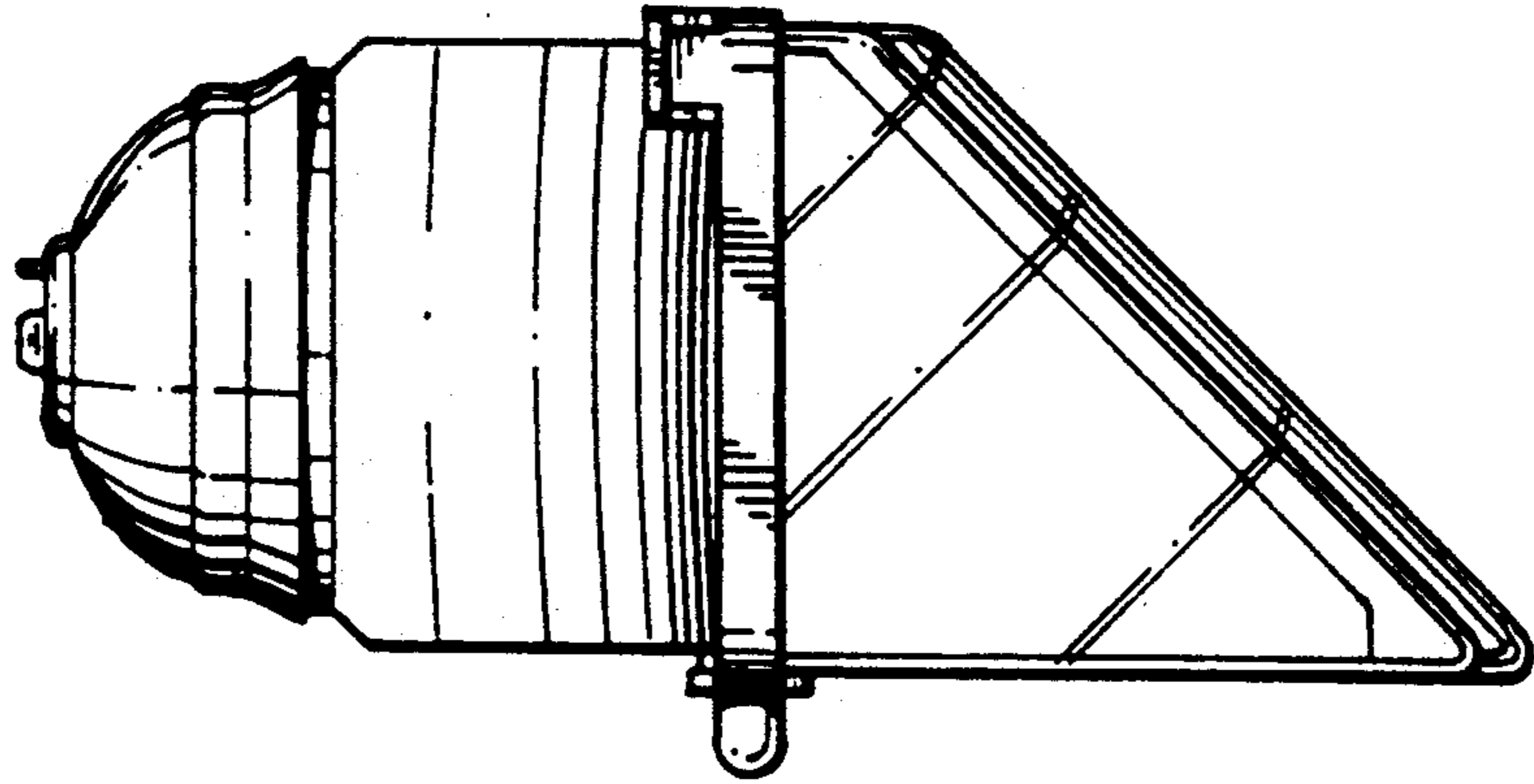

FIG. 6

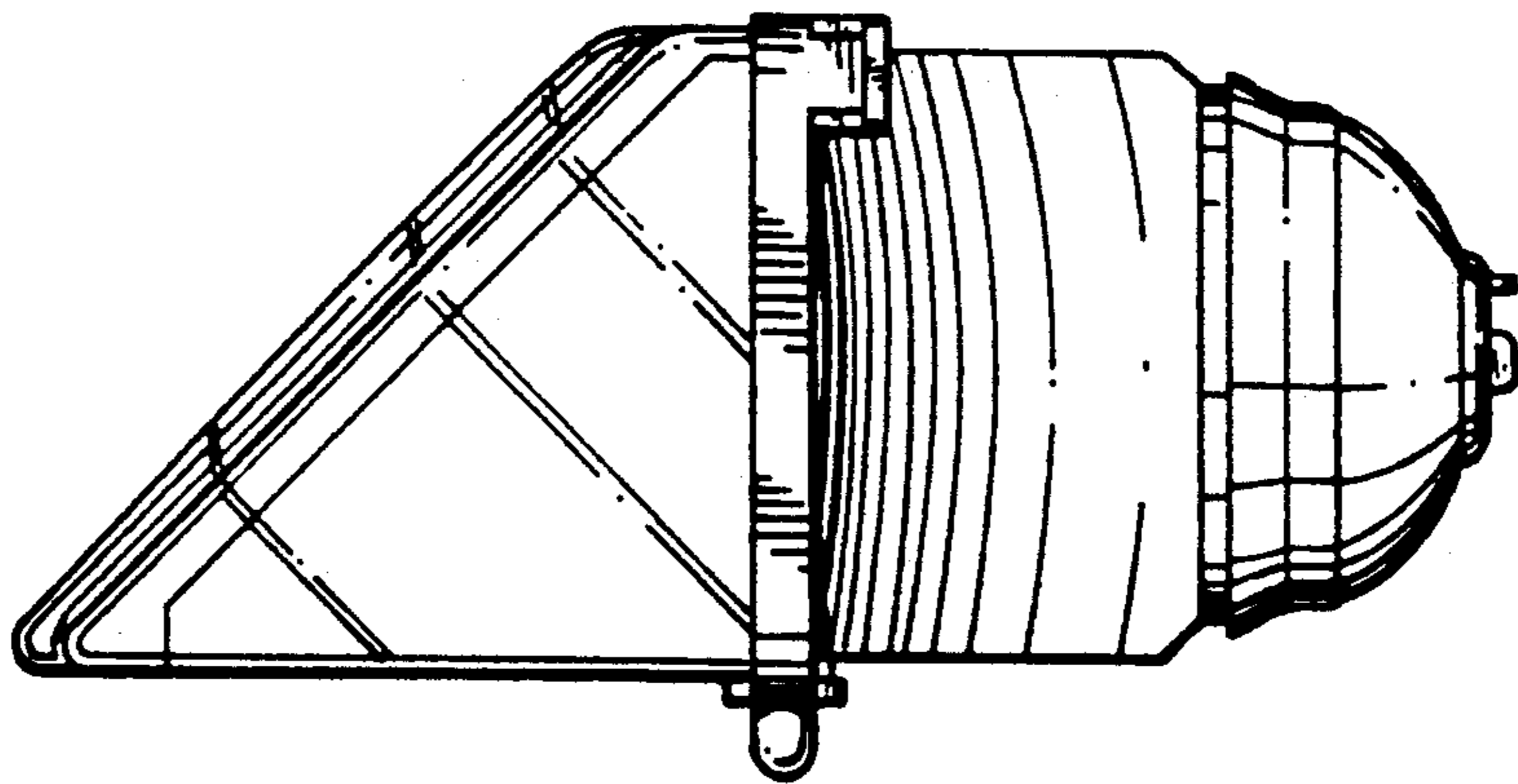

FIG. 7