



US00D323872S

United States Patent [19]

Robbins et al.

[11] Patent Number: **Des. 323,872**

[45] Date of Patent: **** Feb. 11, 1992**

[54] **THUMB REST FOR BAITCAST REEL**

4,943,012 7/1990 Aoki 242/310 X

[75] Inventors: **Richard J. Robbins, Derby, Kans.;**
Steven W. Vogts, Broken Arrow,
Okla.

Primary Examiner—A. Hugo Word
Assistant Examiner—Doris V. Coles
Attorney, Agent, or Firm—Wood, Phillips, Mason,
Recktenwald & VanSanten

[73] Assignee: **Zebco Corporation, Tulsa, Okla.**

[57] **CLAIM**

[**] Term: **14 Years**

The ornamental design of a thumb rest for baitcast reel,
as shown and described.

[21] Appl. No.: **304,335**

DESCRIPTION

[22] Filed: **Jan. 31, 1989**

[52] U.S. Cl. **D22/140**

[58] Field of Search **D22/140; 242/236, 261,**
242/294, 295; 310

FIG. 1 is a front and side perspective view of a thumb rest for baitcast reel, showing our new design; the broken line showing of a reel is for illustrative purposes only and form no part of claimed design;
FIG. 2 is a rear and side perspective view thereof;
FIG. 3 is a top plan view thereof;
FIG. 4 is a bottom plan view thereof;
FIG. 5 is a right side elevation view thereof;
FIG. 6 is a left side elevational view thereof;
FIG. 7 is a front elevational view thereof; and
FIG. 8 is a rear elevational view thereof.

[56] **References Cited**

U.S. PATENT DOCUMENTS

D. 290,635	6/1987	Nakamura	D22/140
1,379,692	5/1921	Pflueger	242/294
1,495,296	5/1924	Foss	242/294
2,555,824	6/1951	Stout	242/294
4,575,024	3/1986	Kaneko	242/261
4,662,585	5/1987	Neufeld	242/236
4,760,973	8/1988	Hlava	242/236 X
4,819,893	4/1989	Ueno	242/261

The broken lines shown in several of the views are for illustrative purposes only and form no part of the claimed design.

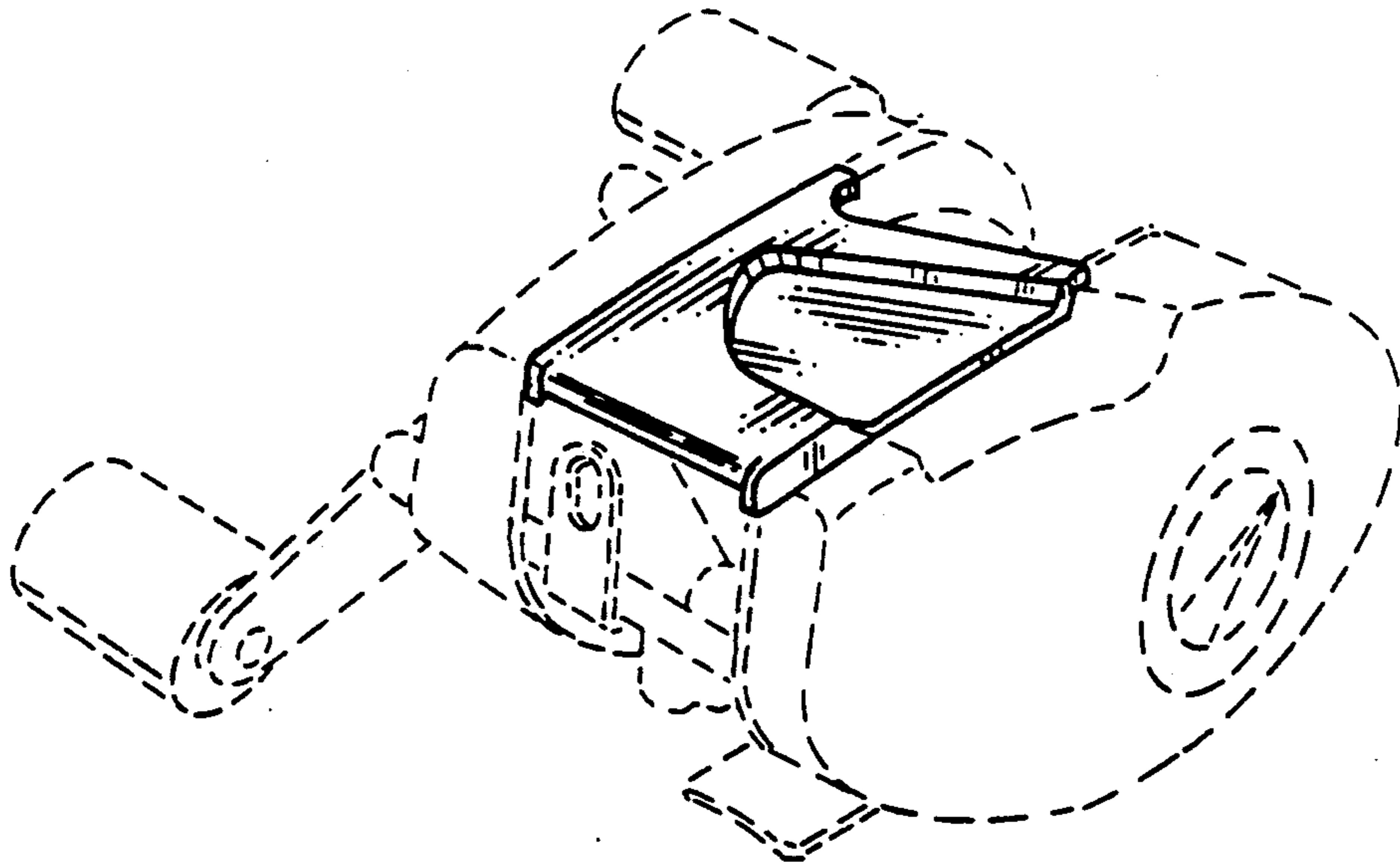

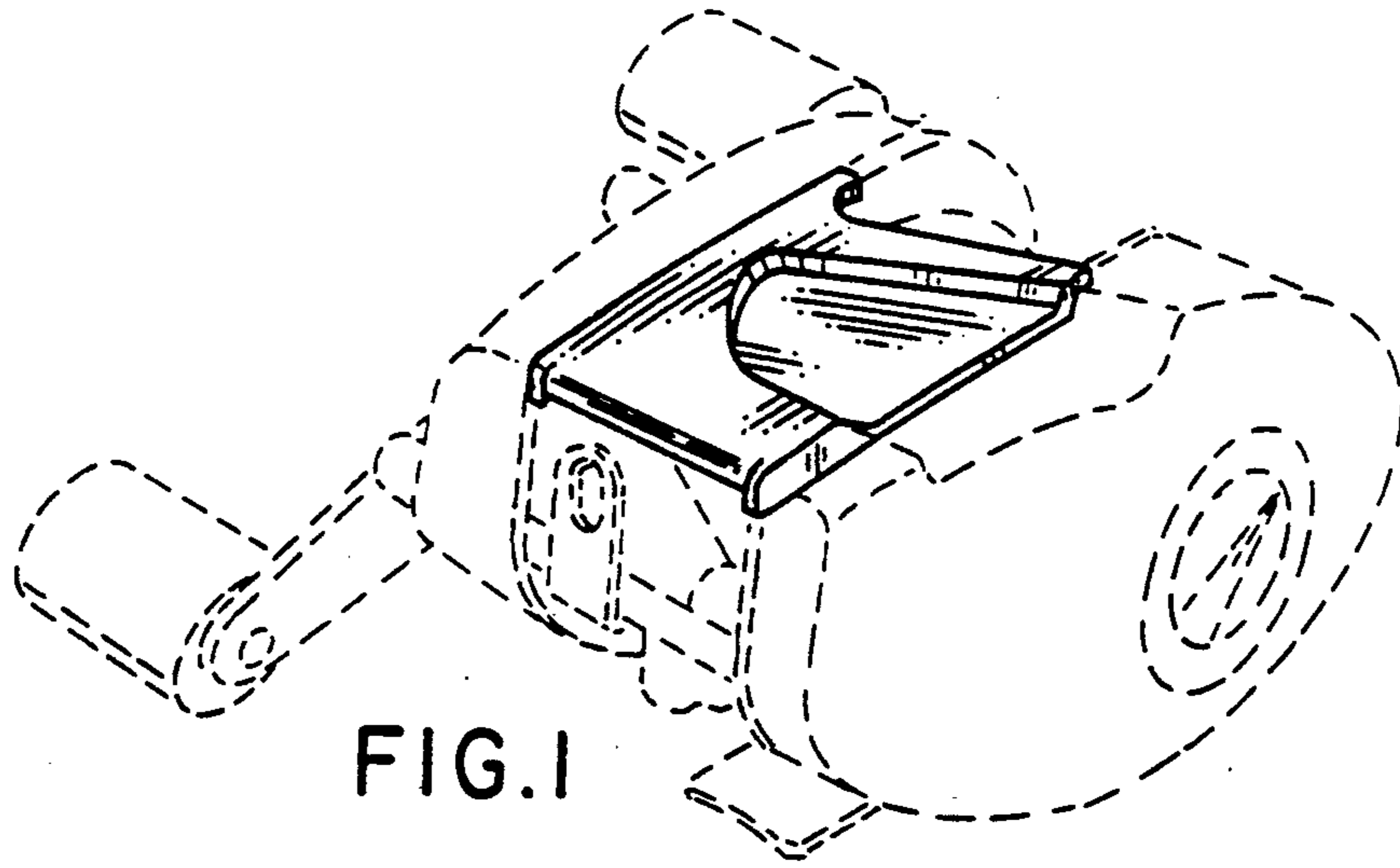

FIG. 1

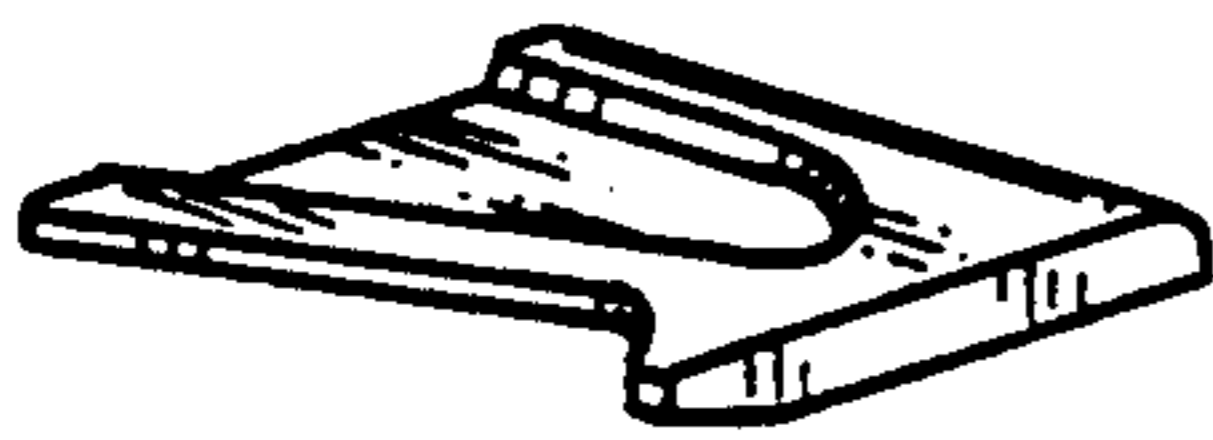

FIG. 2

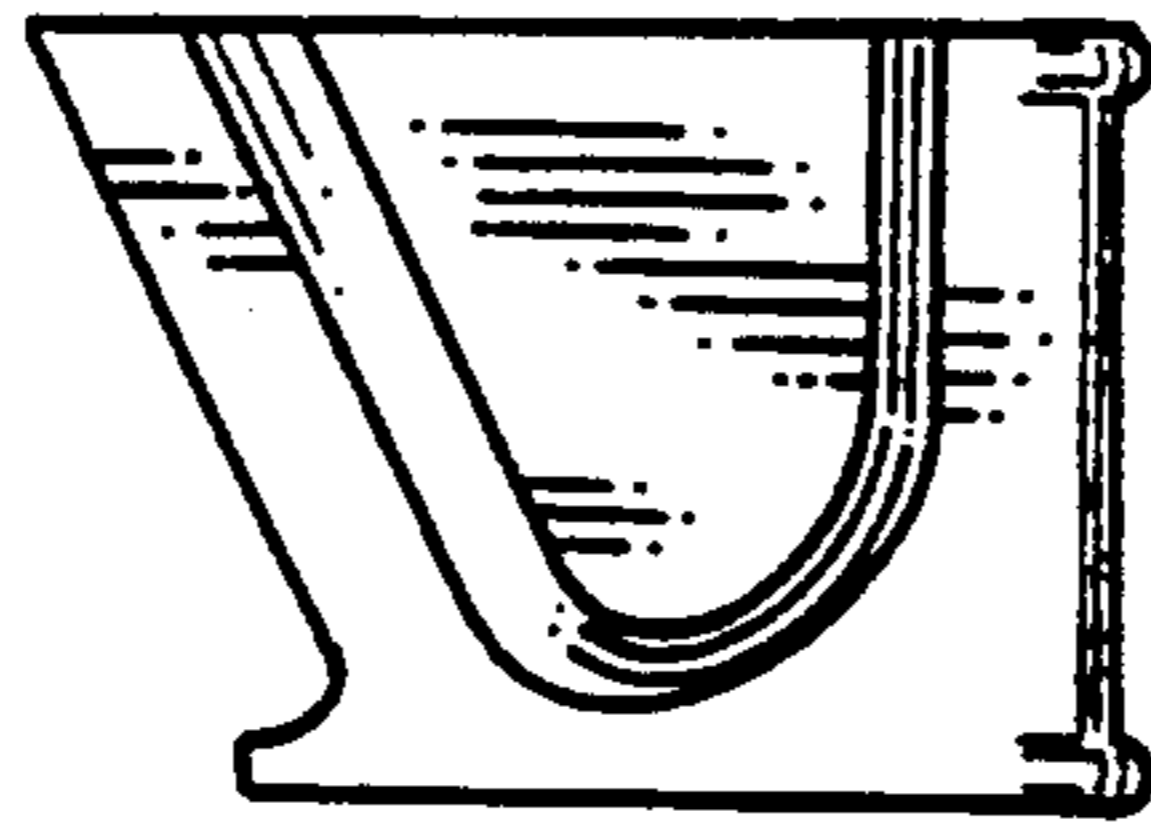

FIG. 3

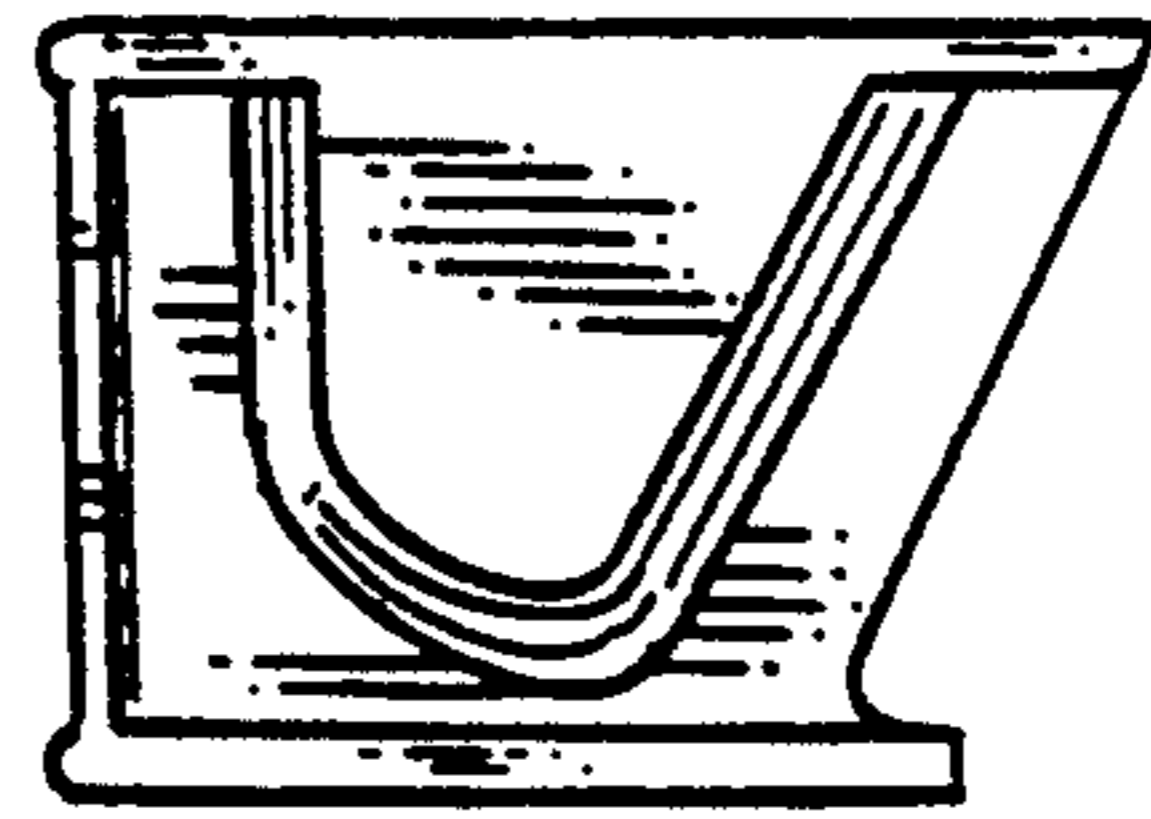

FIG. 4



FIG. 5



FIG. 6



FIG. 7



FIG. 8