



US00D323798S

# United States Patent [19]

Shimazu et al.

[11] Patent Number: Des. 323,798

[45] Date of Patent: \*\* Feb. 11, 1992

[54] AUTOMOBILE

D. 311,710 10/1990 Tsuyoshi et al. .... D12/92

[75] Inventors: Yoshihisa Shimazu, Tokyo;  
Toshihiko Shimizu; Motoaki Minowa,  
both of Saitama, all of Japan

[73] Assignee: Honda Giken Kogyo Kabushiki  
Kaisha, Tokyo, Japan

[\*\*] Term: 14 Years

[21] Appl. No.: 385,262

[22] Filed: Jul. 24, 1989

[52] U.S. Cl. .... D12/92

[58] Field of Search .... D12/91, 92; 296/185

[56] References Cited

### U.S. PATENT DOCUMENTS

D. 276,600	12/1984	Nakano et al. ....	D12/92
D. 289,390	4/1987	Ikeda et al. ....	D12/91
D. 298,522	11/1988	Nakano et al. ....	D12/92
D. 301,436	6/1989	Mizuno et al. ....	D12/92
D. 301,847	6/1989	Ikeda et al. ....	D12/92
D. 301,848	6/1989	Kurosu et al. ....	D12/92
D. 311,361	10/1990	Fujimura et al. ....	D12/92

### OTHER PUBLICATIONS

Motor Trend, 6/85, p. 32, Honda Quint Integra, center of page.

Motor Trend, 9/84, p. 22, Rover's Honda, bottom right side of page.

Road & Track, 4/84, Honda/Rover, bottom left side of page, p. 80D.

Road & Track, 8/88, p. 102, Ford Thunderbird Coupe, top of page.

Primary Examiner—James M. Gandy

Attorney, Agent, or Firm—Lyon & Lyon

### [57] CLAIM

The ornamental design for an automobile, as shown.

### DESCRIPTION

FIG. 1 is a side elevation view of the left side of an automobile showing our new design;

FIG. 2 is a side elevation view of the right side thereof;

FIG. 3 is a top plan view thereof;

FIG. 4 is a front elevation view thereof; and

FIG. 5 is a rear elevation view thereof.

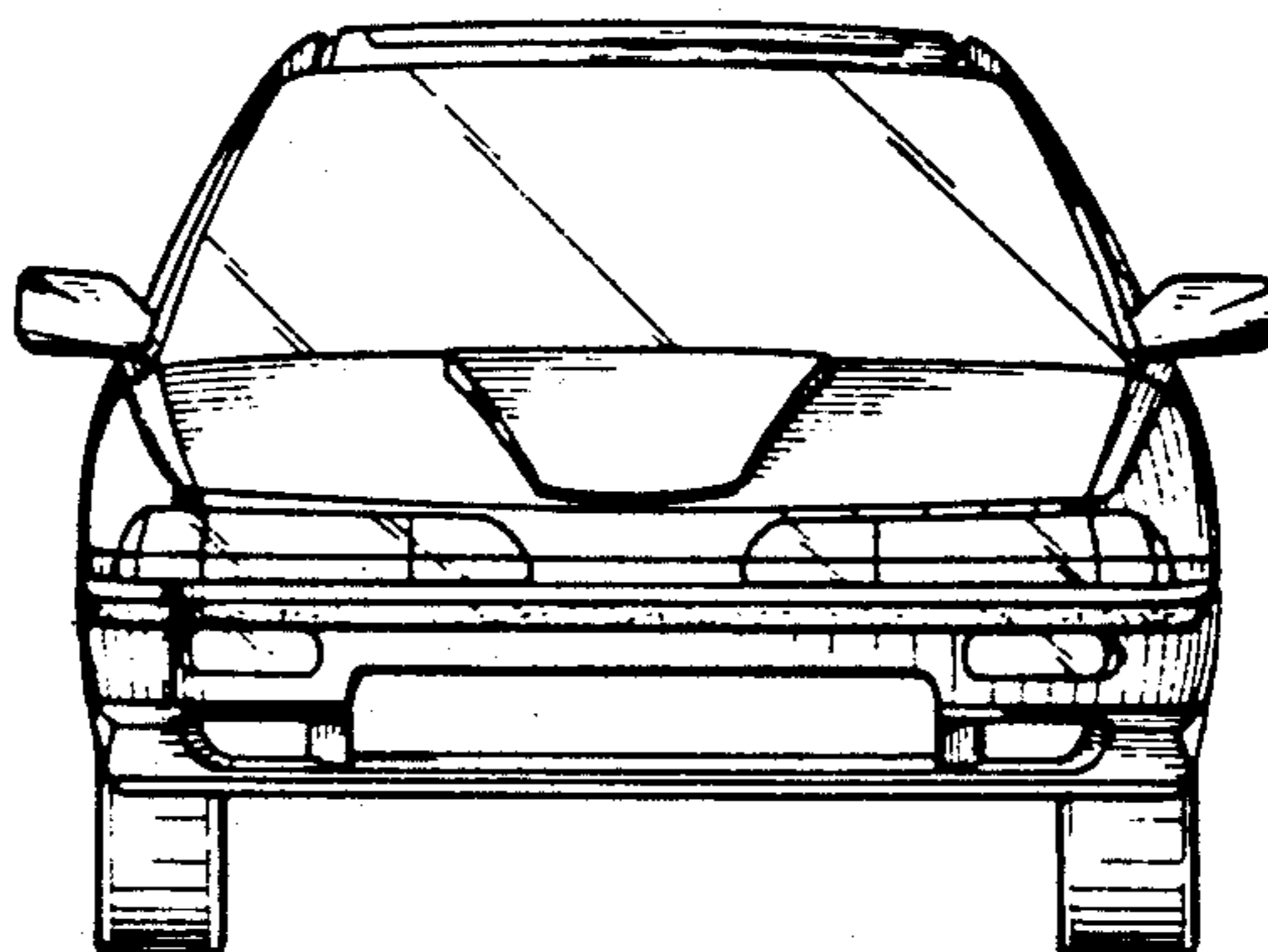
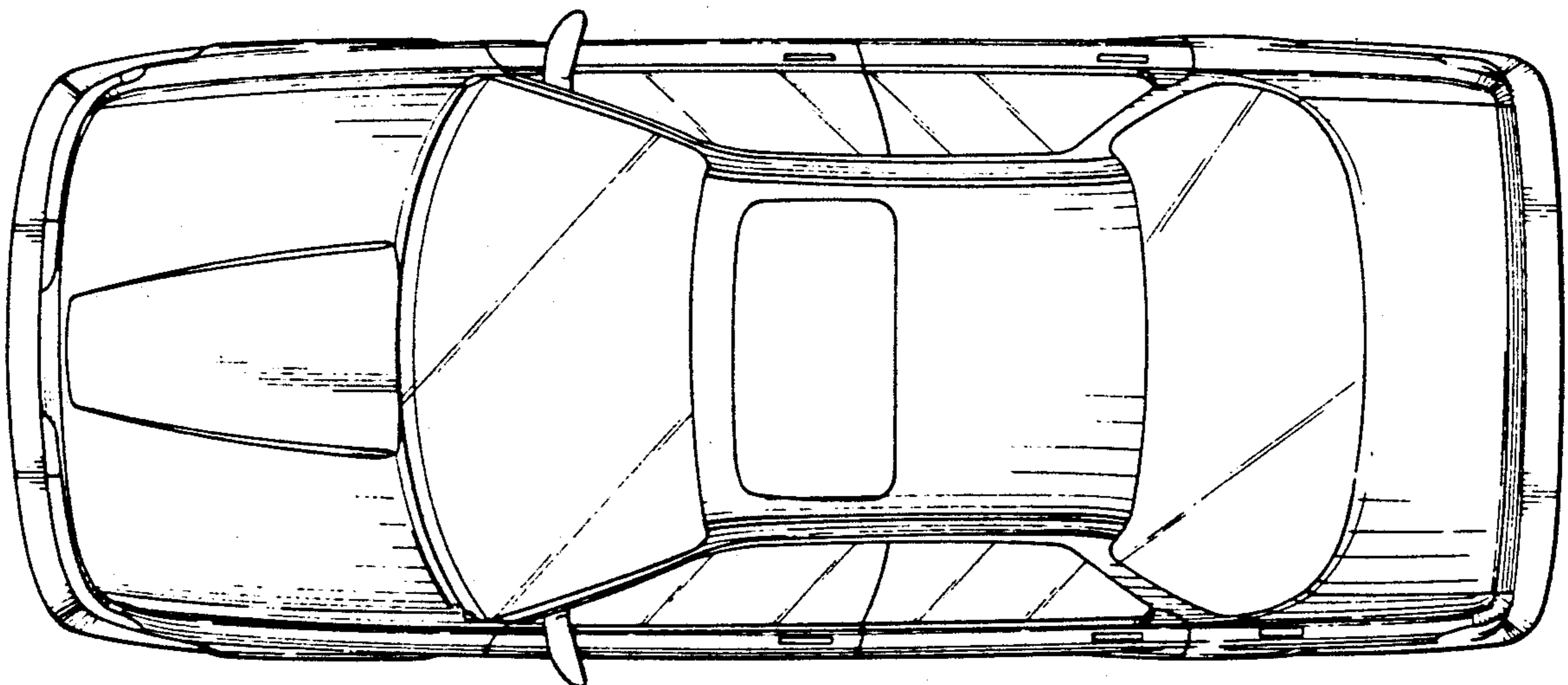

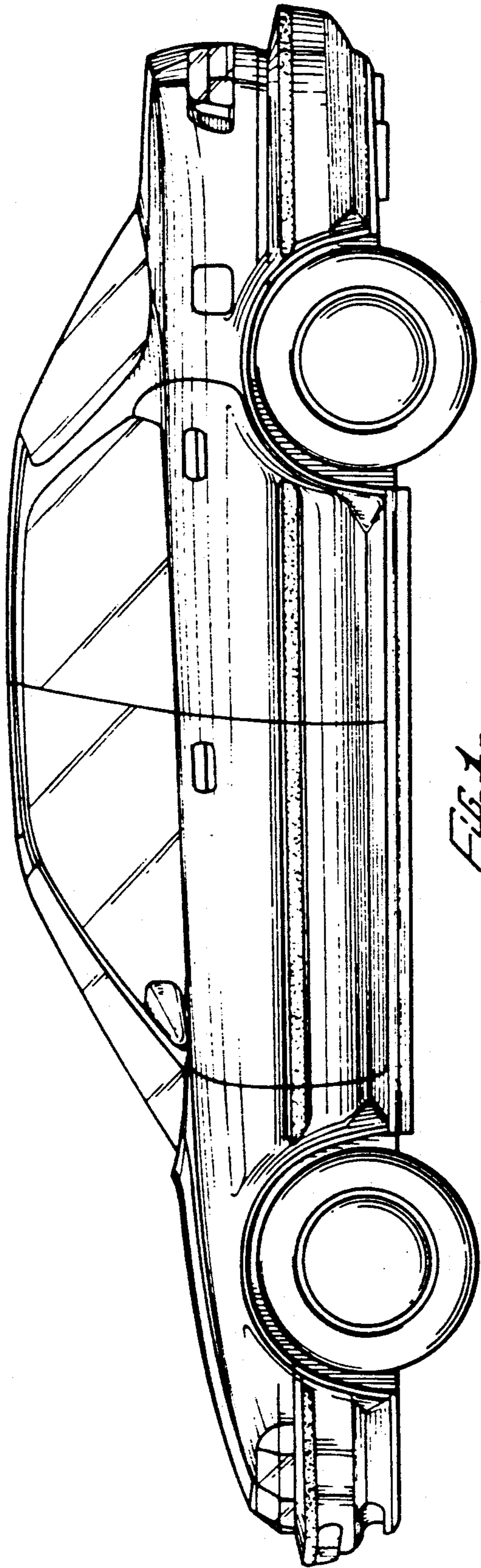

FIG. 1-

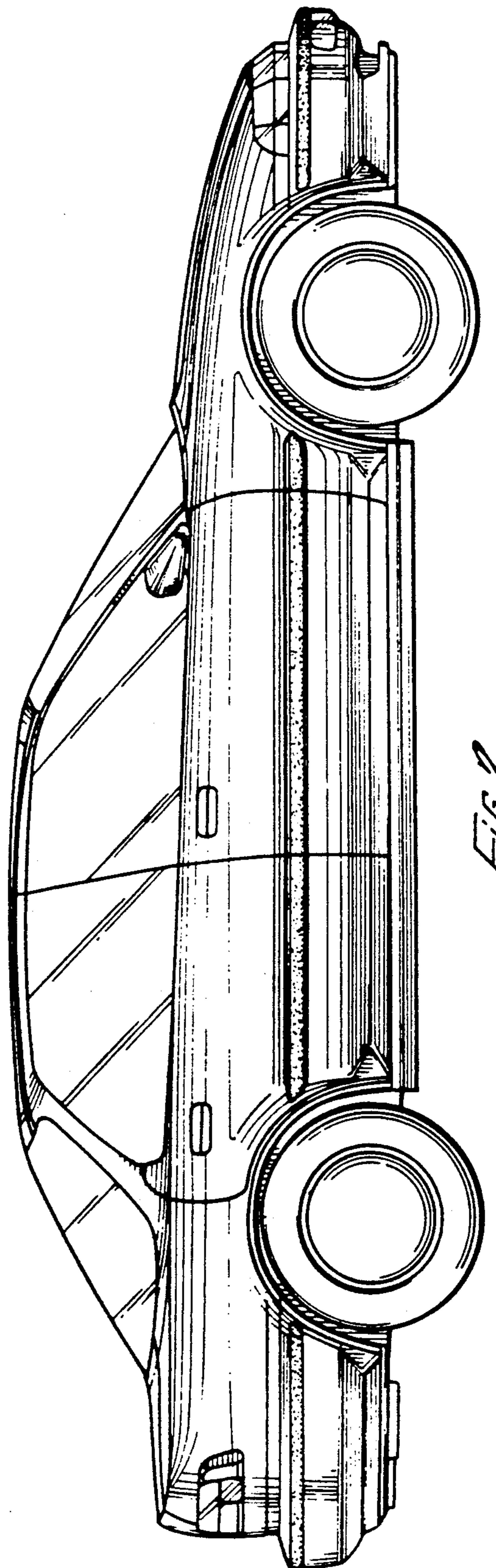

FIG. 2-

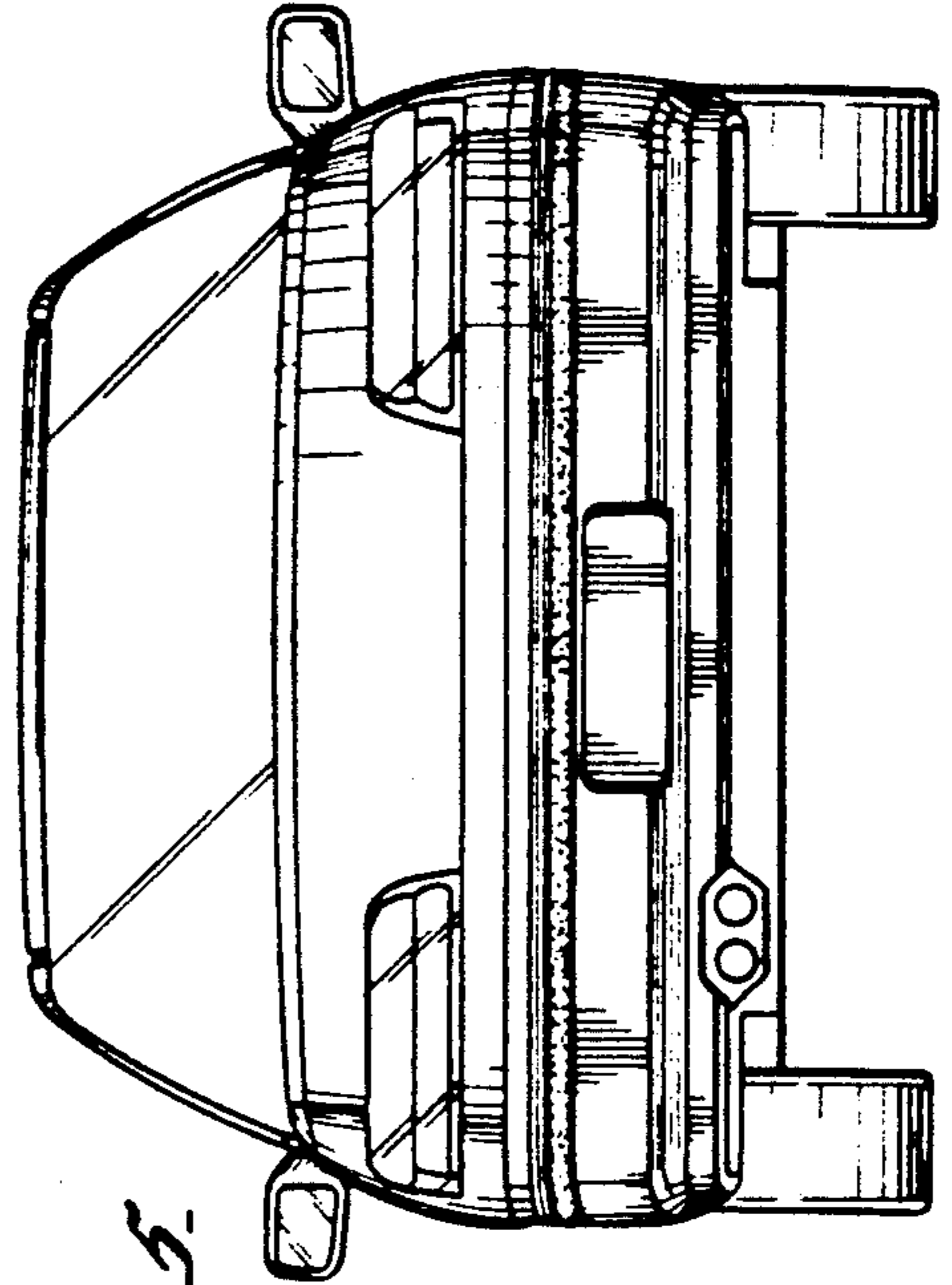
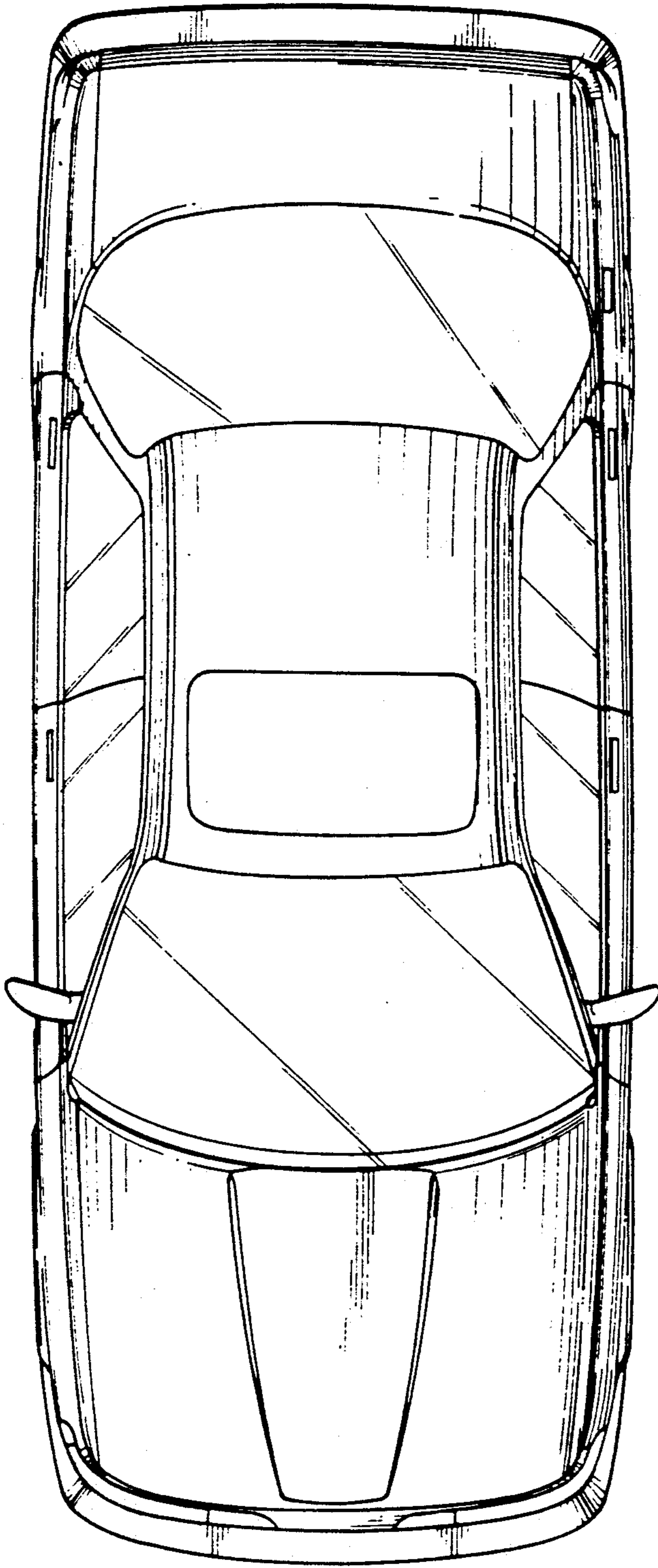

FIG. 9.

FIG. 5.

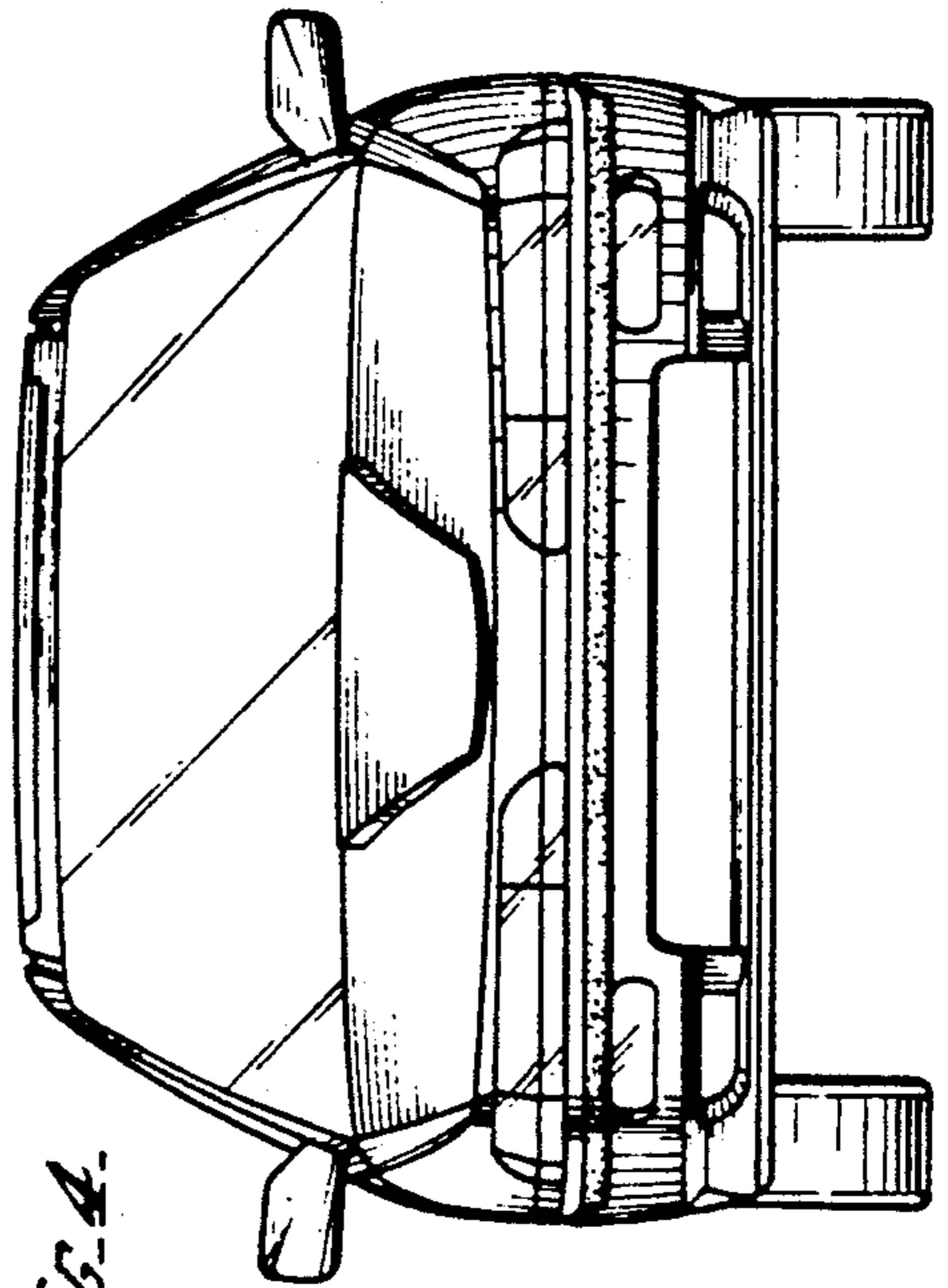

FIG. 4.