



US00D323508S

United States Patent [19]

Hirshberg et al.

[11] Patent Number: Des. 323,508

[45] Date of Patent: ** Jan. 28, 1992

[54] OUTBOARD MOTOR

[75] Inventors: Gerald P. Hirshberg, Del Mar;
Douglas G. Wilson, Carlsbad, both of
Calif.; Masayuki Akahori, Yamoto,
Japan

[73] Assignees: Nissan Motor Co., Ltd., Yokohama;
Nissan Kohki Company Ltd.,
Kanagawa, both of Japan

[**] Term: 14 Years

[21] Appl. No.: 412,315

[22] Filed: Sep. 26, 1989

[52] U.S. Cl. D15/4

[58] Field of Search D15/4; 440/52-53,
440/3-4, 6, 900; 290/43, 46, 54

[56]

References Cited

U.S. PATENT DOCUMENTS

4,512,294 4/1985 Mohr 440/900
4,811,717 3/1989 Nakahama 123/495

Primary Examiner—A. Hugo Word
Assistant Examiner—R. Seifert
Attorney, Agent, or Firm—Foley & Lardner

[57]

CLAIM

The ornamental design for an outboard motor, as shown
and described.

DESCRIPTION

FIG. 1 is a perspective view of an outboard motor
showing our design;
FIG. 2 is a front elevational view thereof;
FIG. 3 is a rear elevational view thereof;
FIG. 4 is a right side elevational view thereof;
FIG. 5 is a left side elevational view thereof;
FIG. 6 is a top plan view thereof; and
FIG. 7 is a bottom plan view thereof.

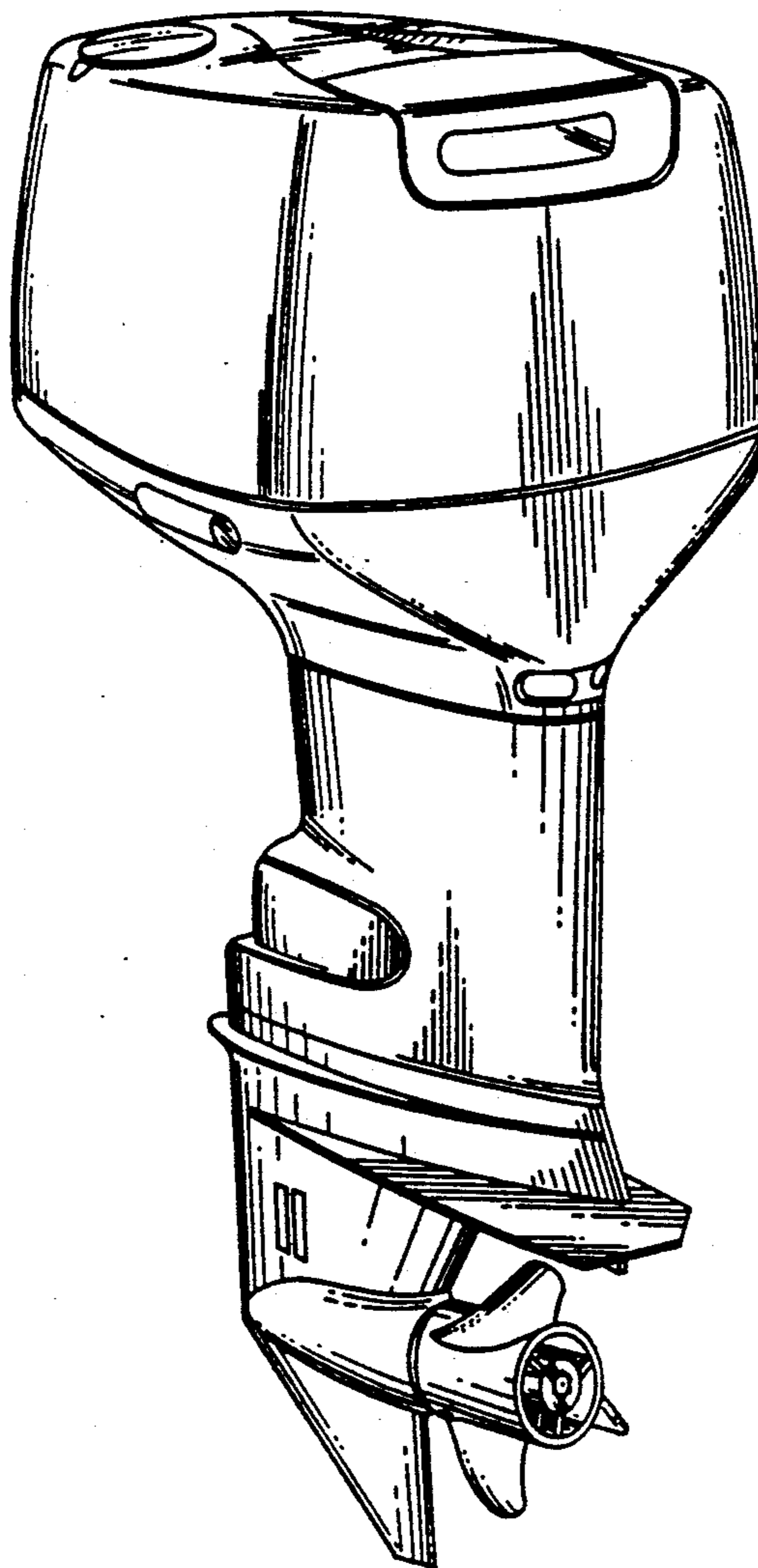

FIG. 1

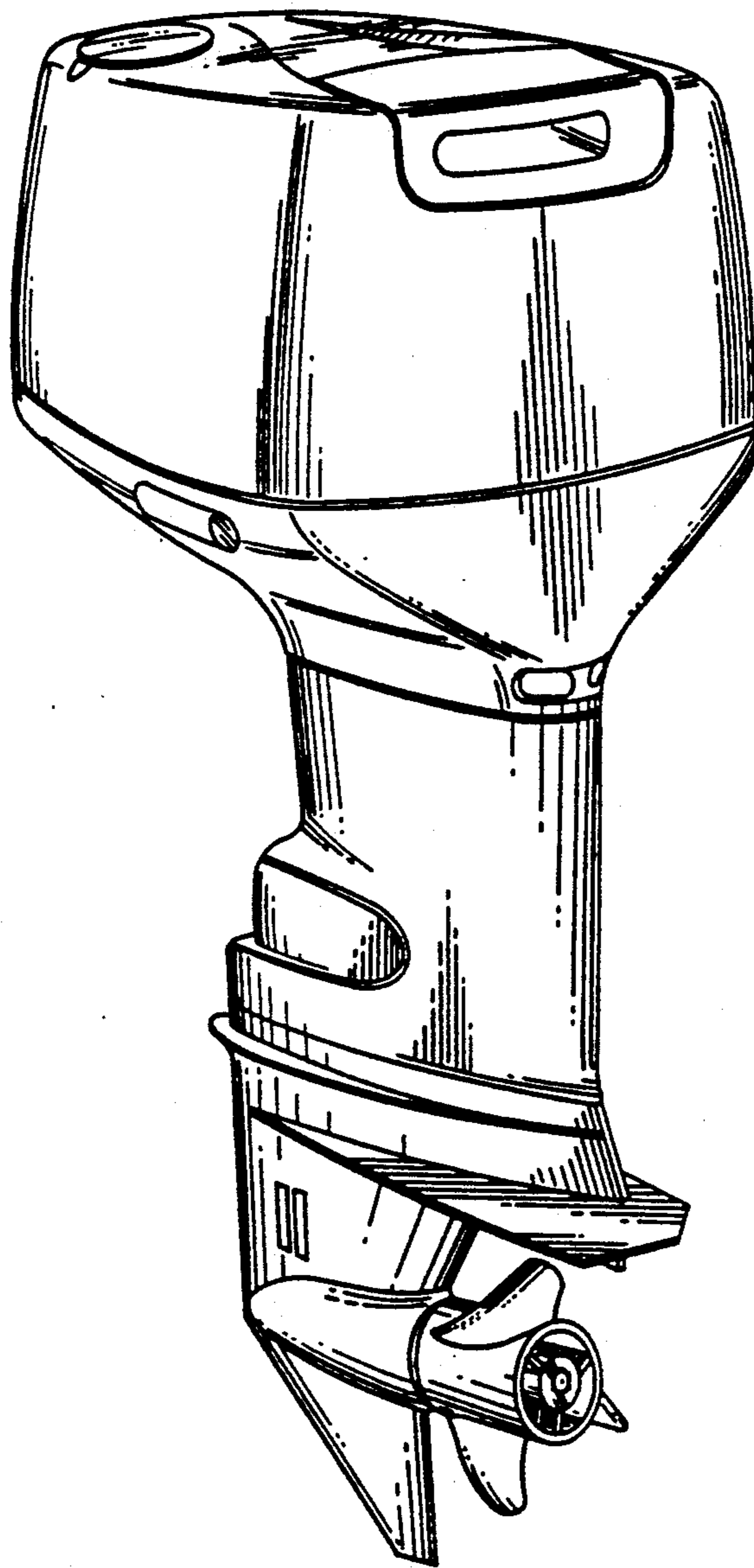

FIG. 2

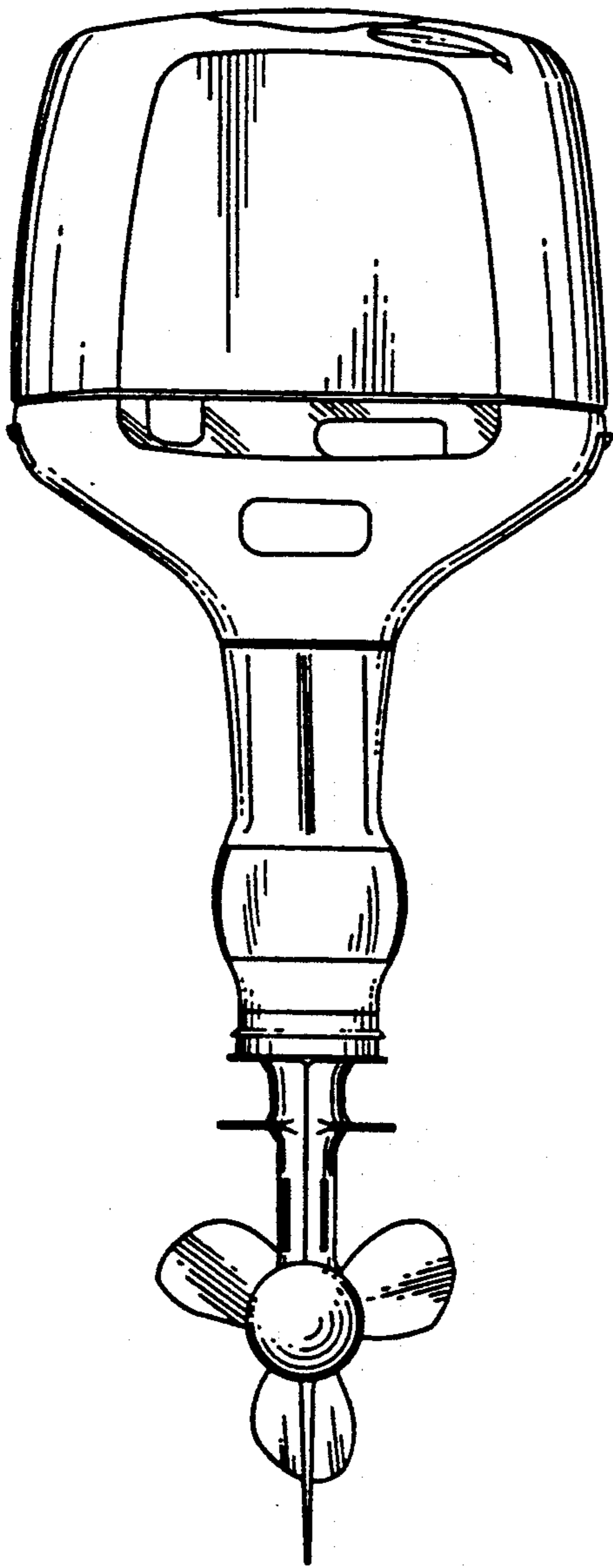

FIG. 3

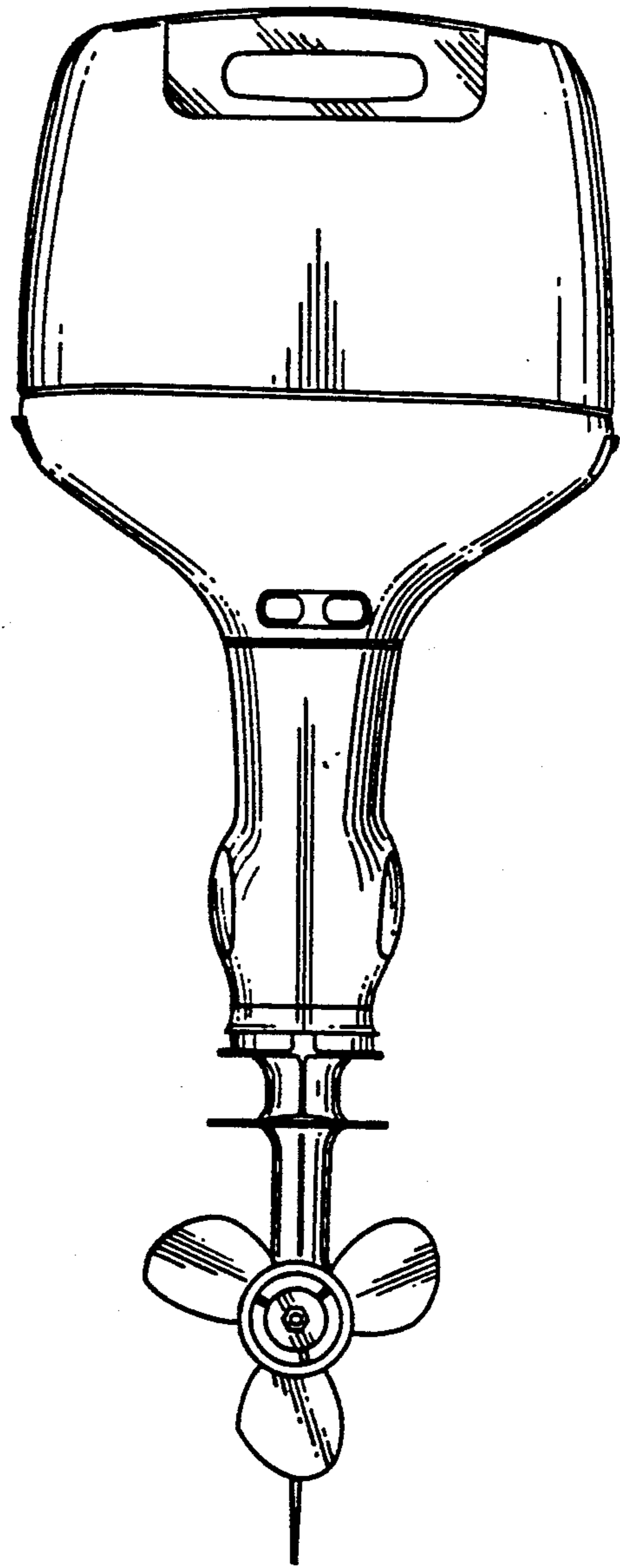

FIG. 5

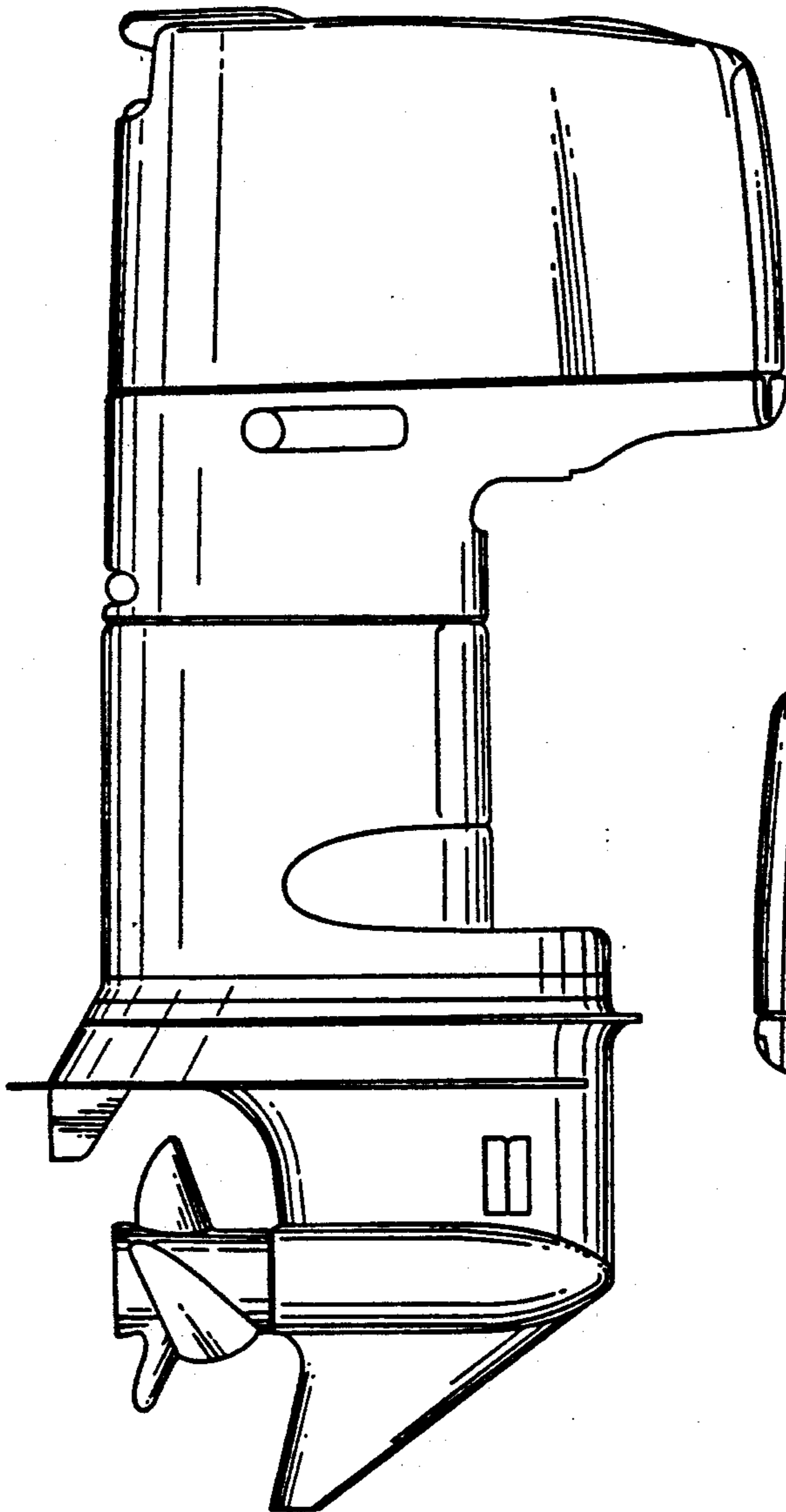

FIG. 4

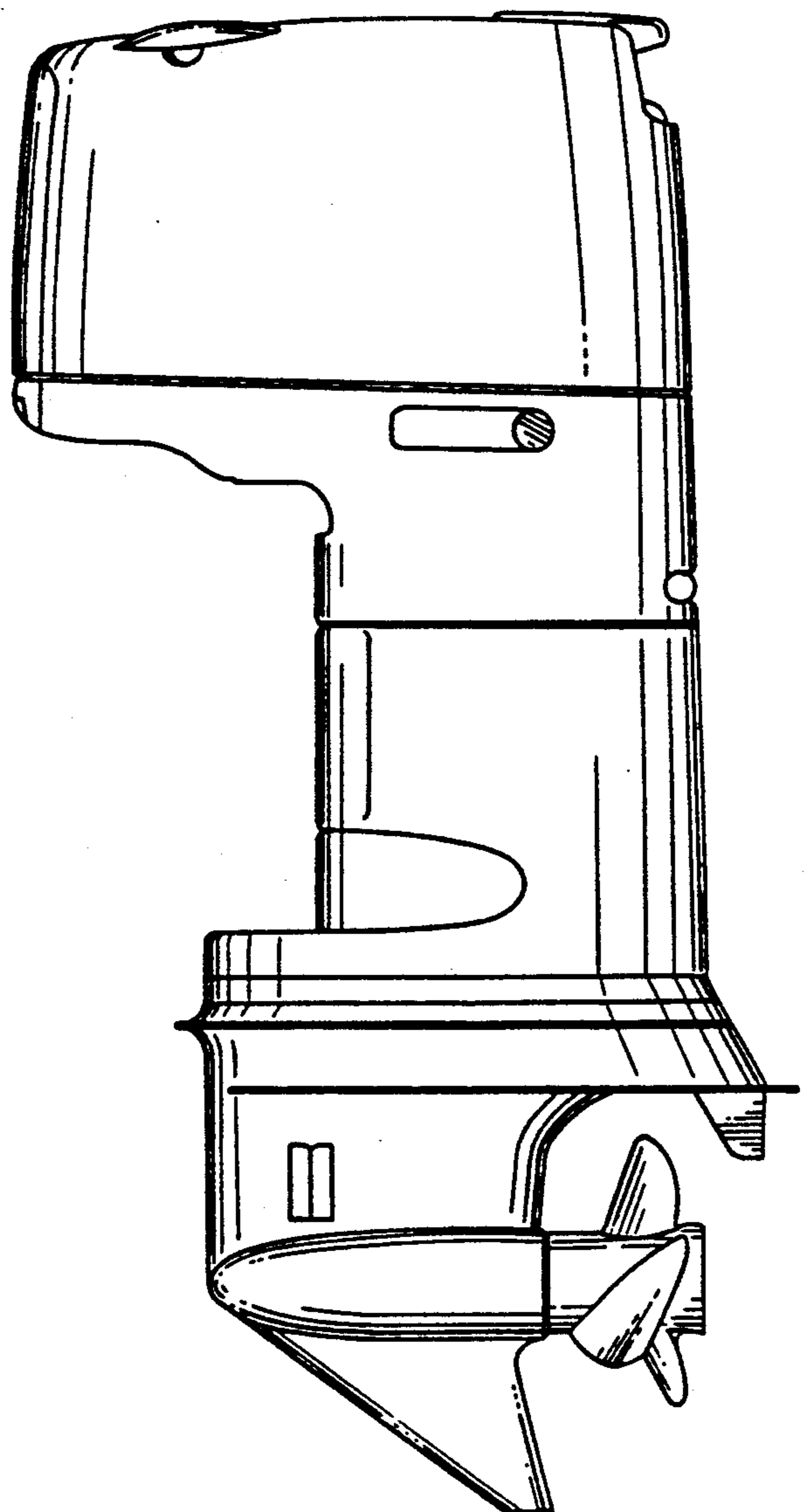

FIG. 6

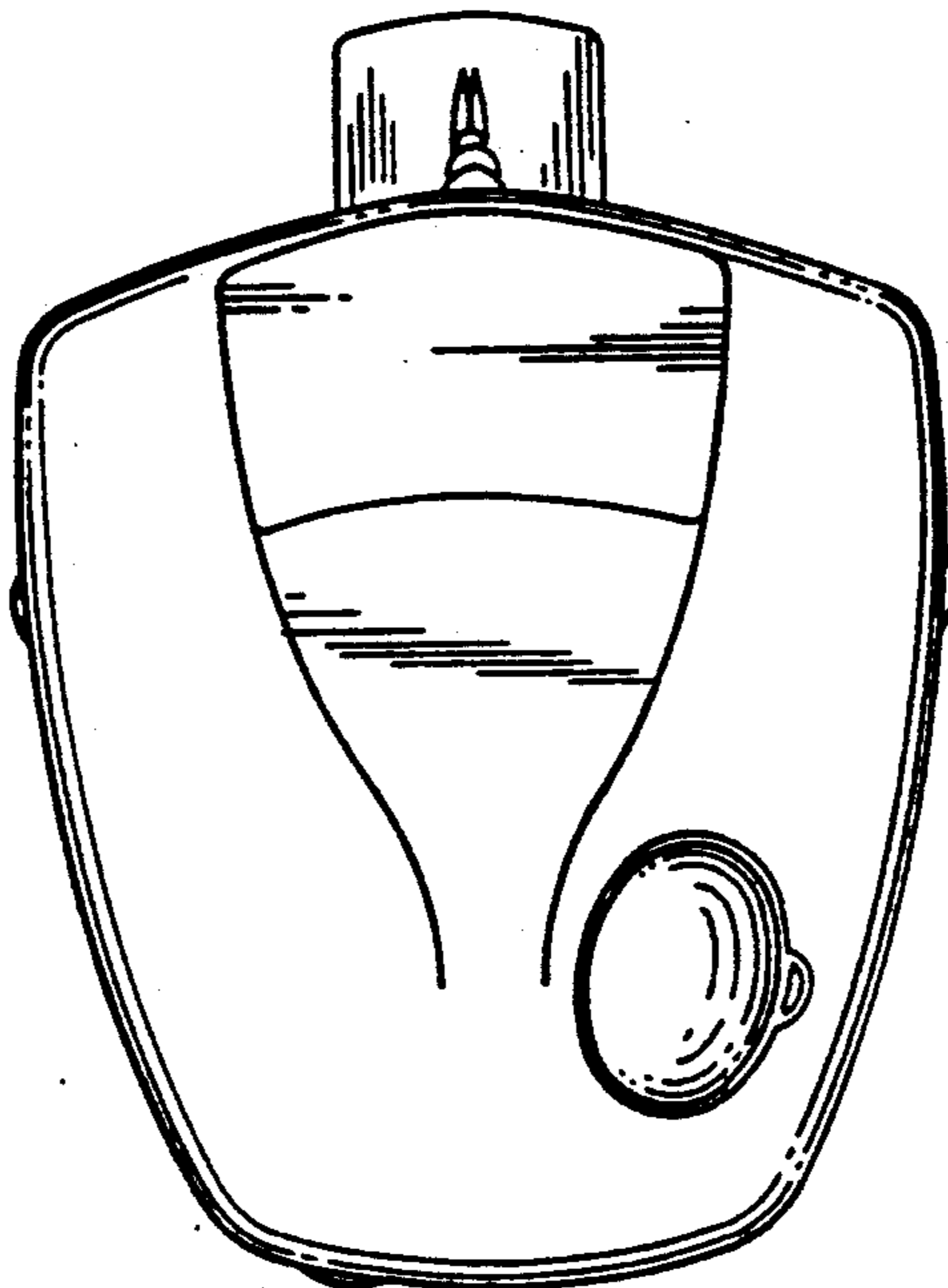

FIG. 7

