



US00D323479S

United States Patent [19]

[11] Patent Number: **Des. 323,479**

Akashi et al.

[45] Date of Patent: **** Jan. 28, 1992**

[54] **TONNEAU-COVER FOR AUTOMOBILE**

Attorney, Agent, or Firm—Laubscher, Presta & Laubscher

[75] Inventors: **Naoyuki Akashi; Hiromu Wada; Yukio Hirano; Tohru Takagi**, all of Fujisawa, Japan

[57] **CLAIM**

The ornamental design for a tonneau-cover for automobile, as shown and described.

[73] Assignee: **Isuzu Motors Limited**, Japan

DESCRIPTION

[**] Term: **14 Years**

[21] Appl. No.: **324,349**

FIG. 1 is a perspective view of a tonneau-cover for automobile showing our new design it being understood that the broken lines are for illustrative purposes only and form no part of the claimed design;

[22] Filed: **Mar. 16, 1989**

[30] **Foreign Application Priority Data**

Sep. 26, 1988 [JP] Japan 63-37411

FIG. 2 is a side elevation view thereof, the opposite side being a mirror image of that shown;

[52] U.S. Cl. **D12/156**

FIG. 3 is a top plan view thereof;

[58] Field of Search D12/156; 296/10, 99.1, 296/100

FIG. 4 is a bottom plan view thereof;

FIG. 5 is a rear elevation view thereof;

[56] **References Cited**

U.S. PATENT DOCUMENTS

D. 281,487 11/1985 Chapman D12/156

D. 294,242 2/1988 O'Neill D12/156

FIG. 6 is a front elevation view thereof;

FIG. 7 is a sectional view thereof taken along line 7—7 in **FIG. 2**;

FIG. 8 is a sectional view thereof taken along line 8—8 in **FIG. 2**; and

FIG. 9 is a sectional view thereof taken along line 9—9 in **FIG. 3**.

Primary Examiner—James M. Gandy

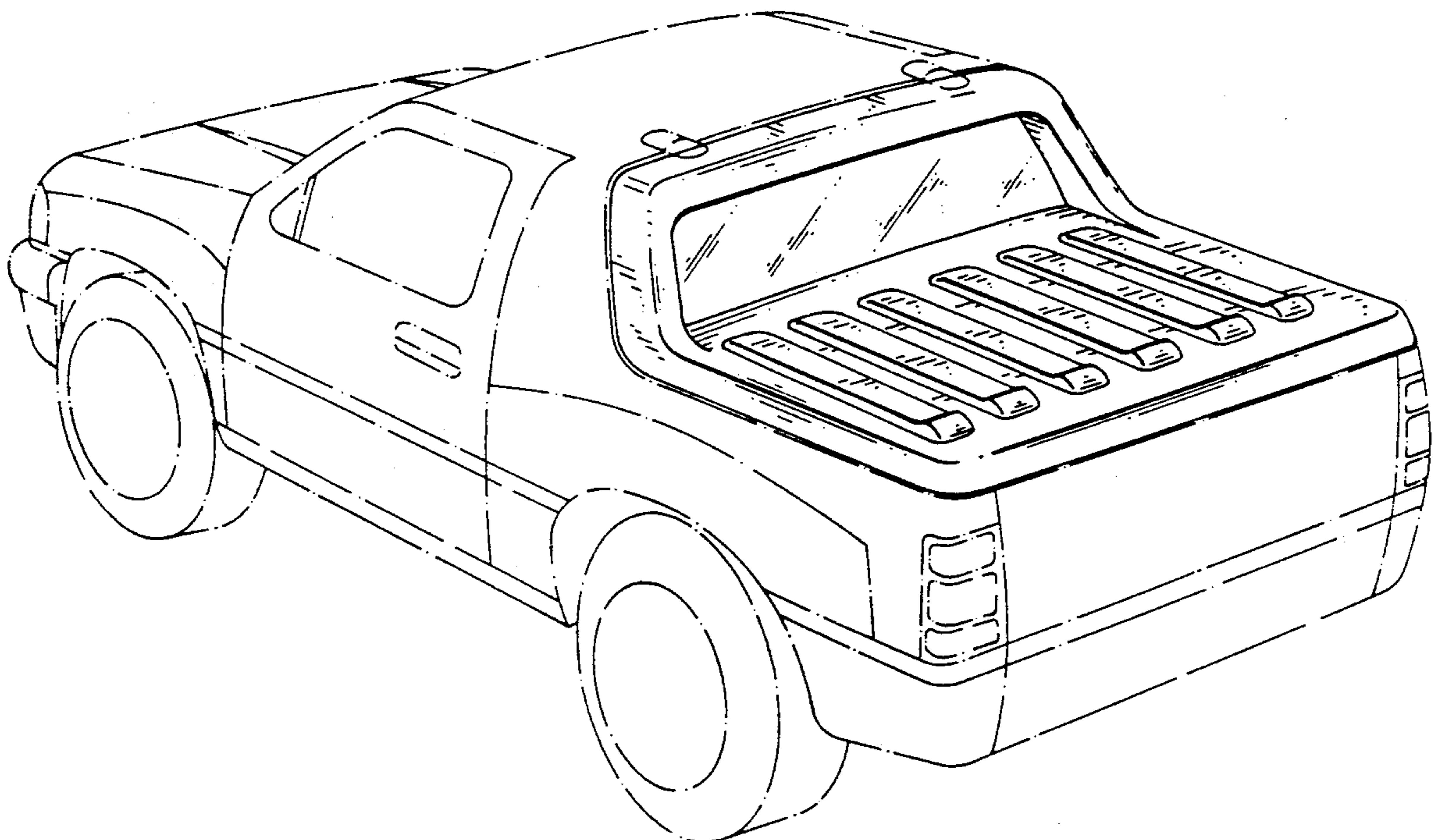

FIG. 1

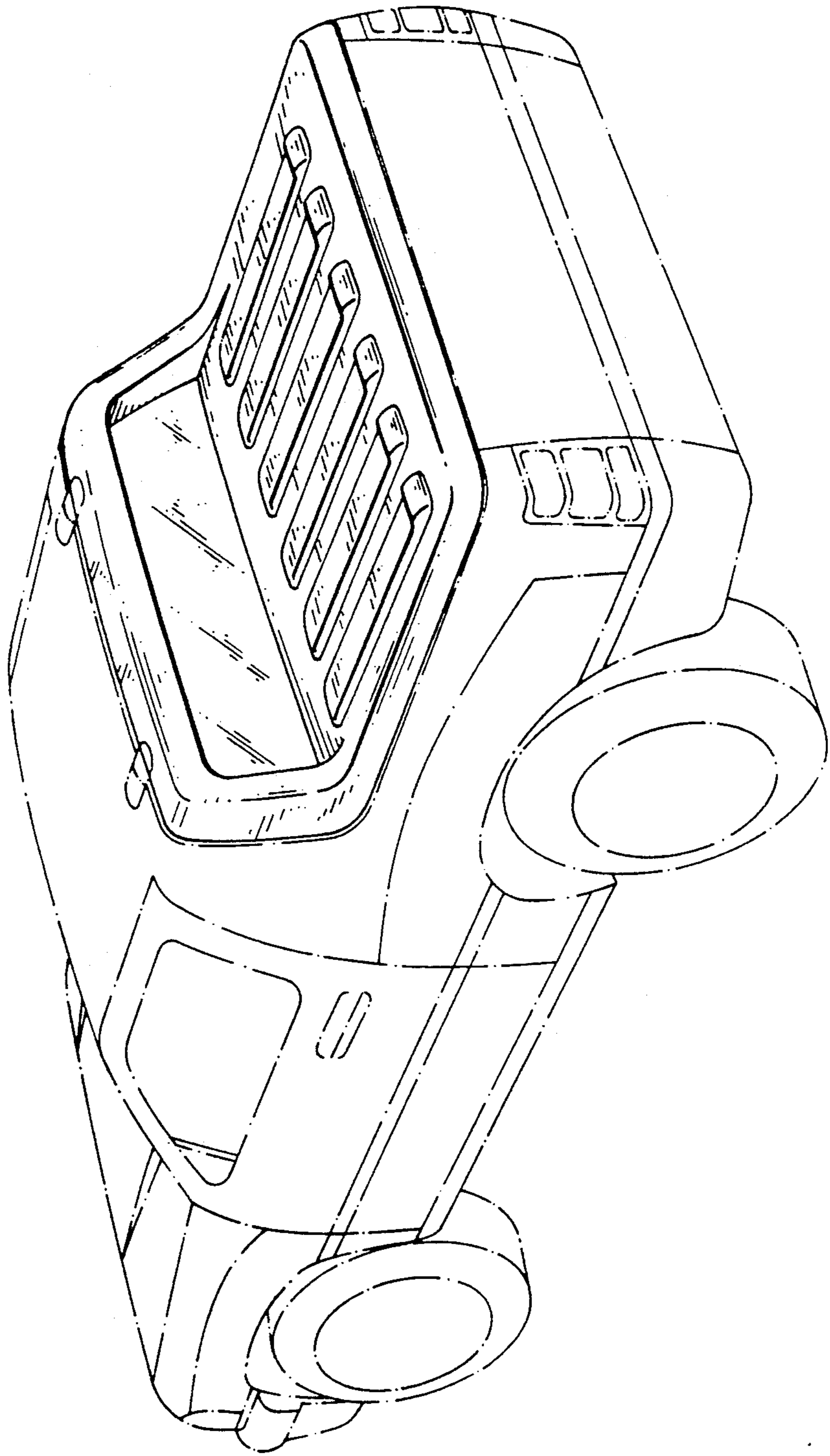

FIG. 2

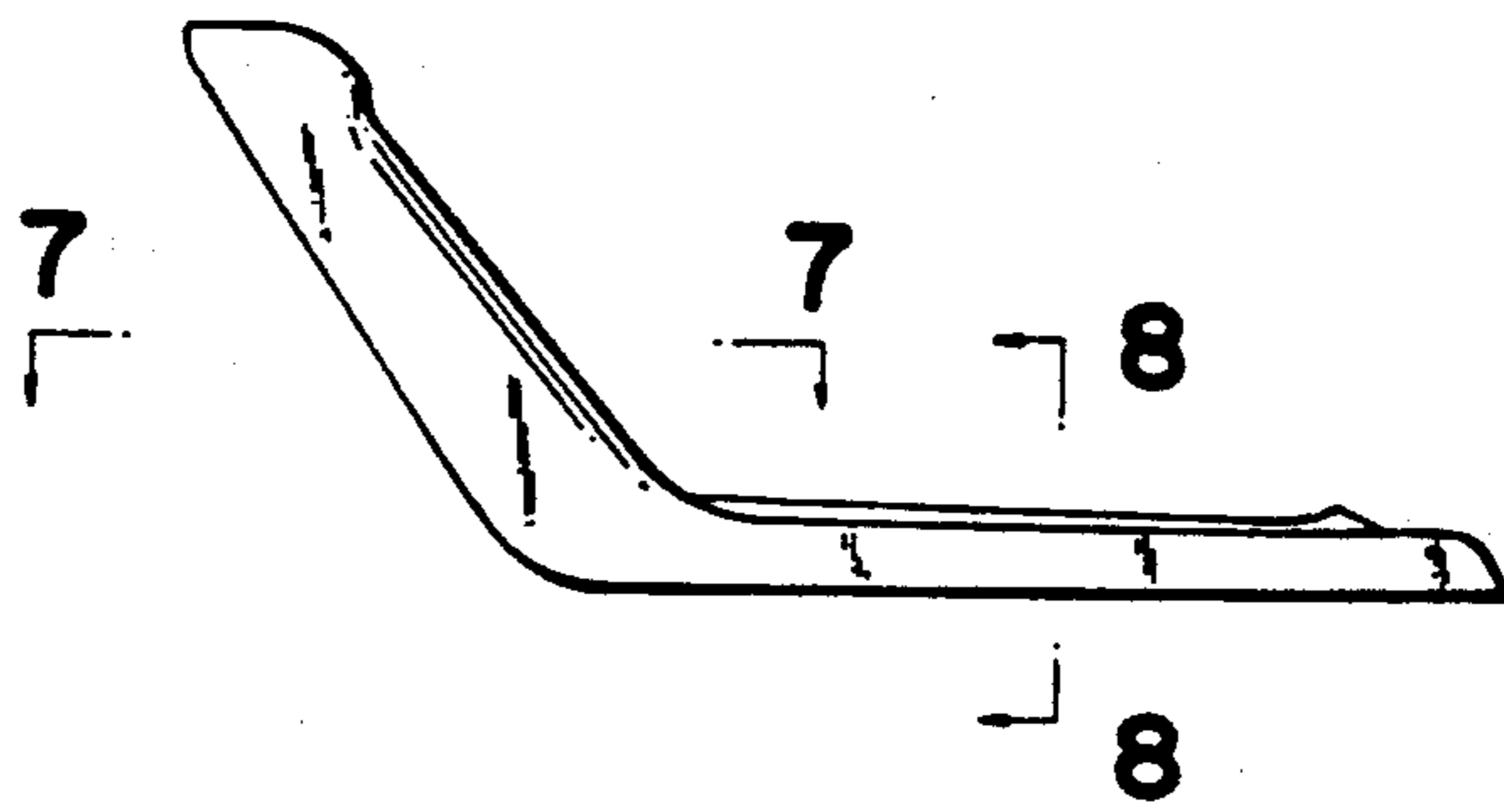

FIG. 3

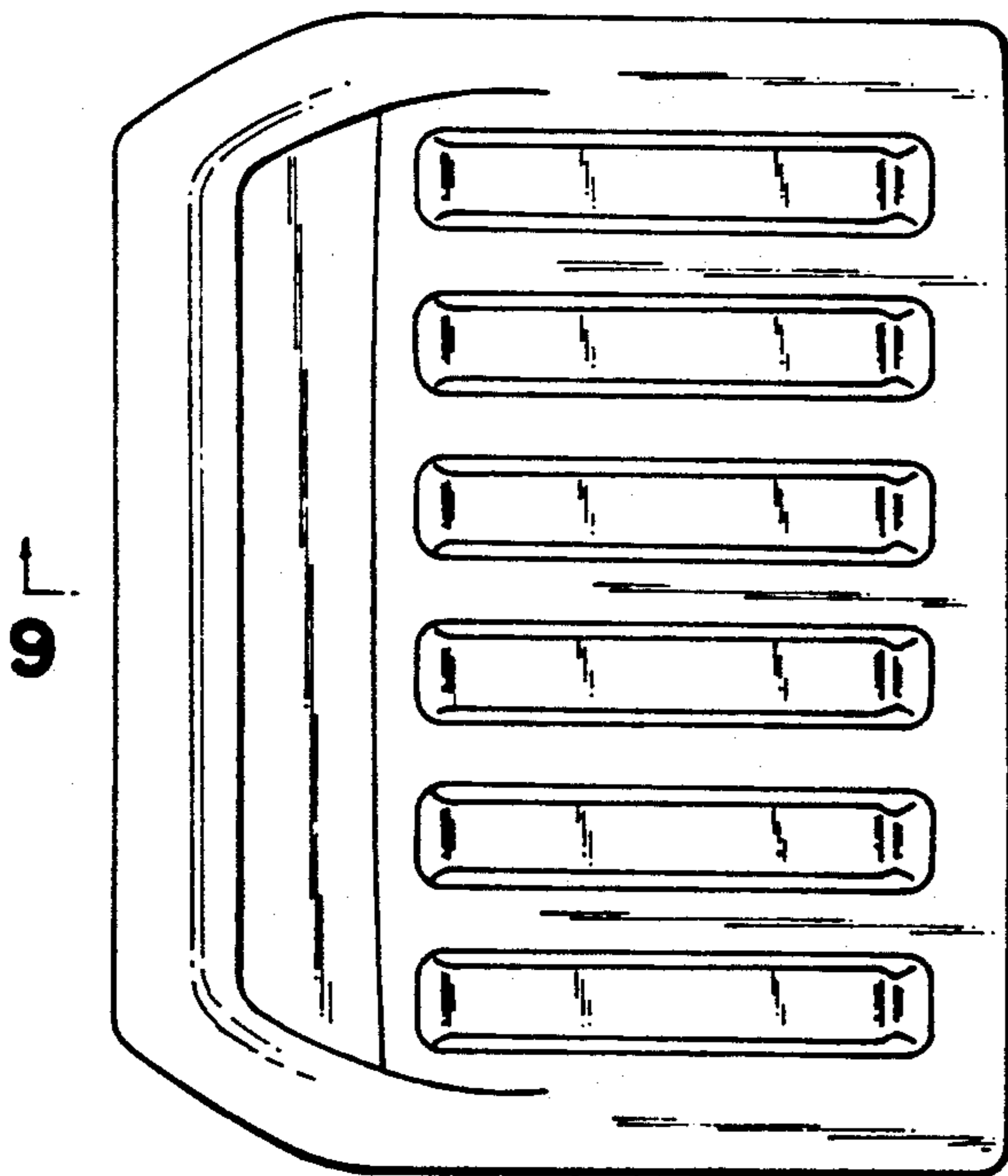

FIG. 4

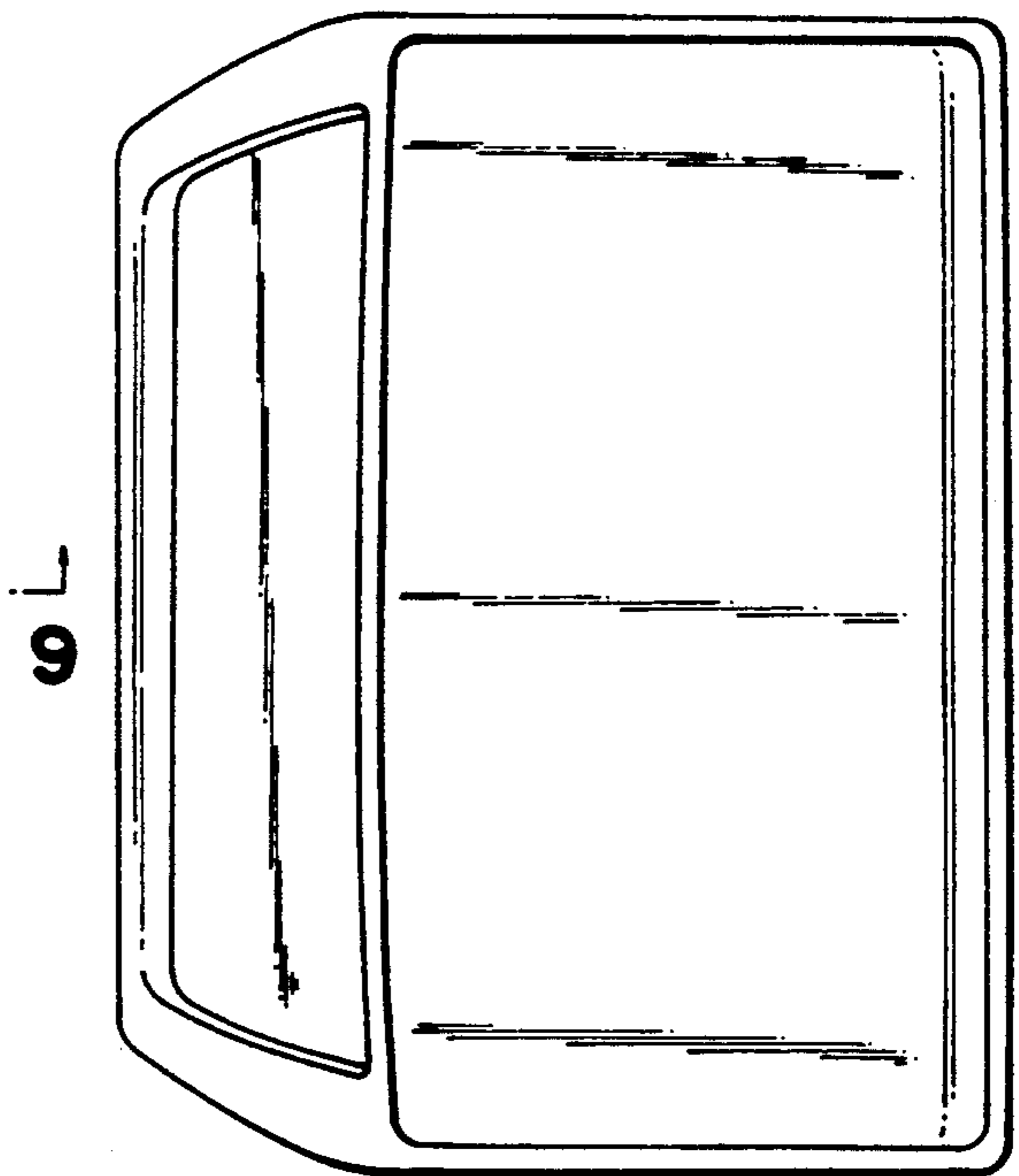

FIG. 5

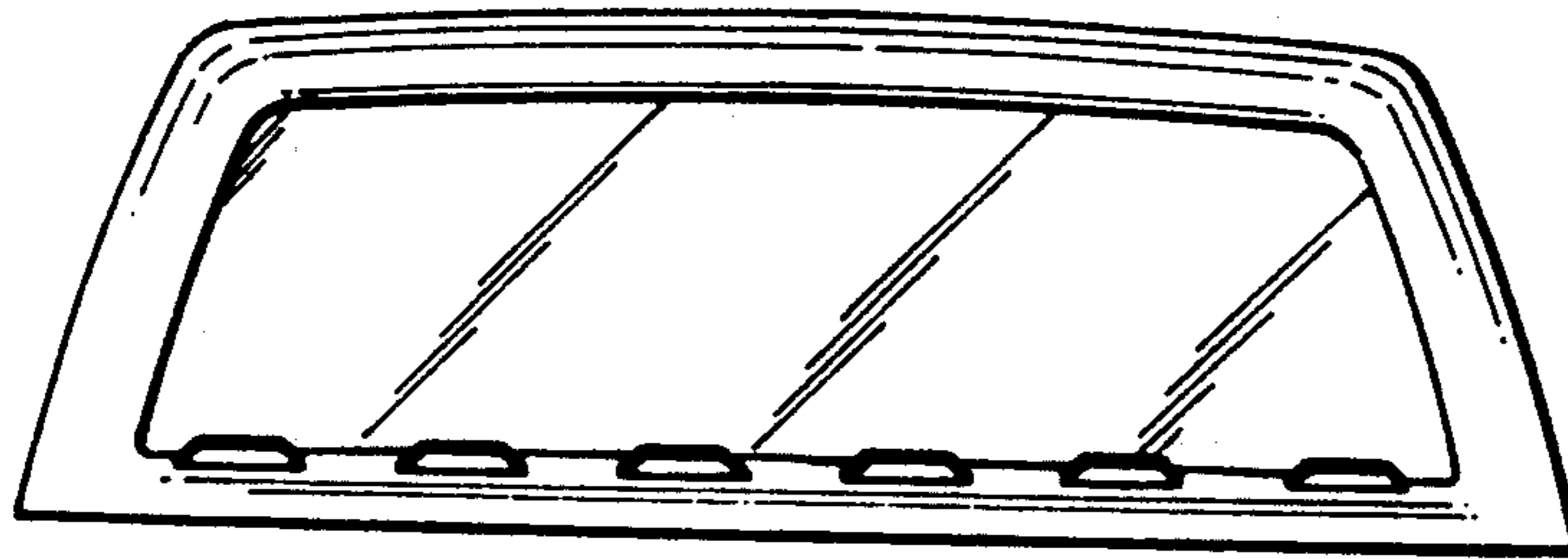

FIG. 6

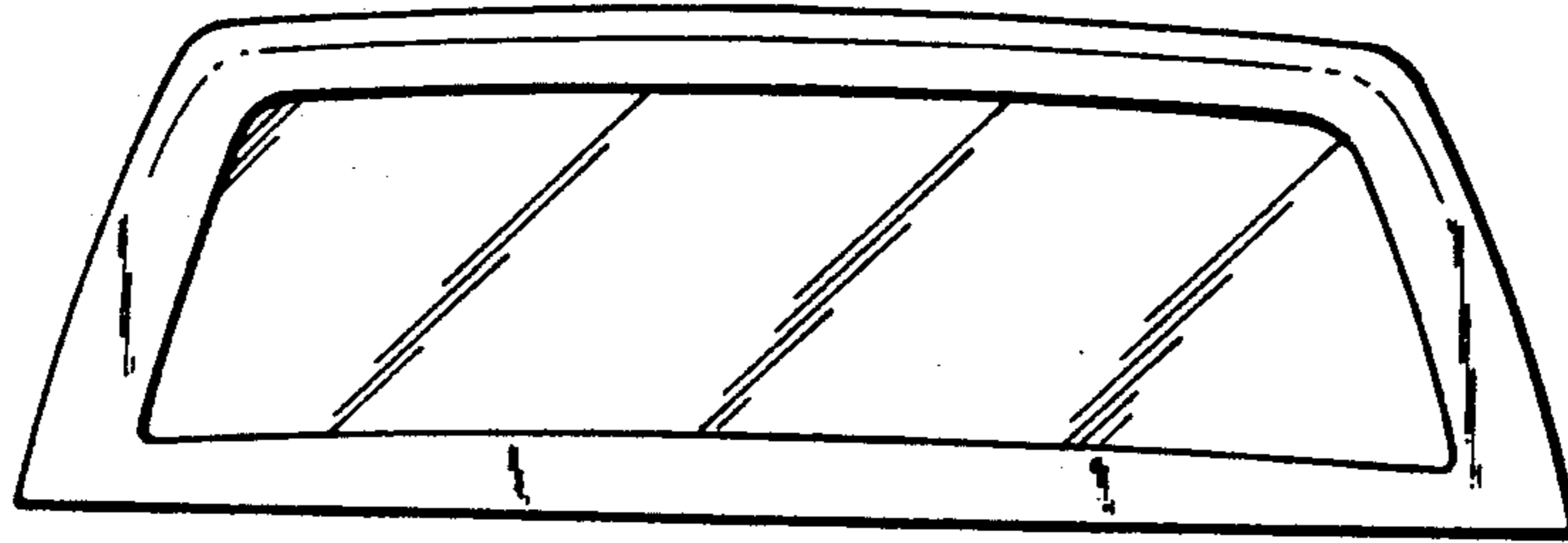

FIG. 7

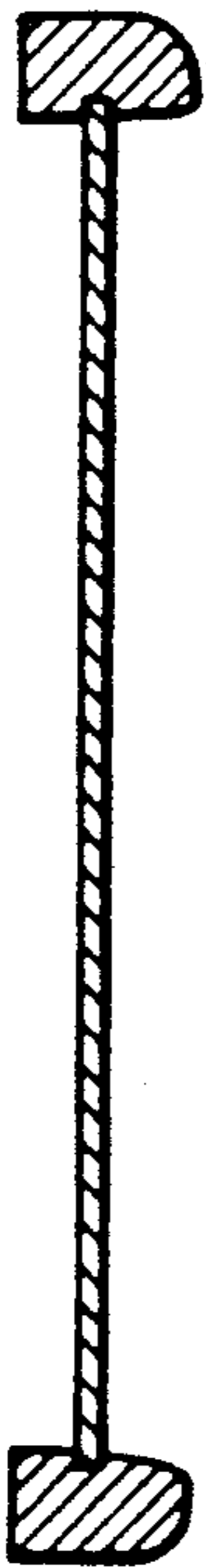

FIG. 8



FIG. 9

