



US00D323408S

United States Patent [19]

[11] Patent Number: **Des. 323,408**

Butler

[45] Date of Patent: **** Jan. 21, 1992**

[54] **ADJUSTABLE LANTERN HOLDER**

2,426,443	8/1947	Fetterman	248/156 X
3,179,144	4/1965	Kimoto	248/309.1 X
3,285,554	11/1956	Voelkerding	248/121

[76] Inventor: **Kenneth W. Butler**, 4376 Ecton Rd., Winchester, Ky. 40391

Primary Examiner—Susan J. Lucas
Attorney, Agent, or Firm—Leon Gilden

[**] Term: **14 Years**

[21] Appl. No.: **476,647**

[57] **CLAIM**

[22] Filed: **Feb. 8, 1990**

The ornamental design for an adjustable lantern holder, as shown and described.

[52] U.S. Cl. **D26/138**

[58] Field of Search D26/138, 140; 362/396; 248/121, 122, 127, 156, 158, 159, 545, 309.1

DESCRIPTION

[56] **References Cited**

FIG. 1 is a front elevational view of the adjustable lantern holder showing my new design; FIG. 2 is a rear elevational view thereof; FIG. 3 is a left side elevational view thereof; FIG. 4 is a right side elevational view thereof; FIG. 5 is a top plan view thereof; and FIG. 6 is a bottom plan view thereof.

U.S. PATENT DOCUMENTS

D. 211,120	5/1968	Sherbert	D26/138
D. 305,071	12/1989	Tripp	D26/138
1,619,307	3/1927	Offenbach	248/121 X
1,933,673	11/1933	Krajnc	248/121 X

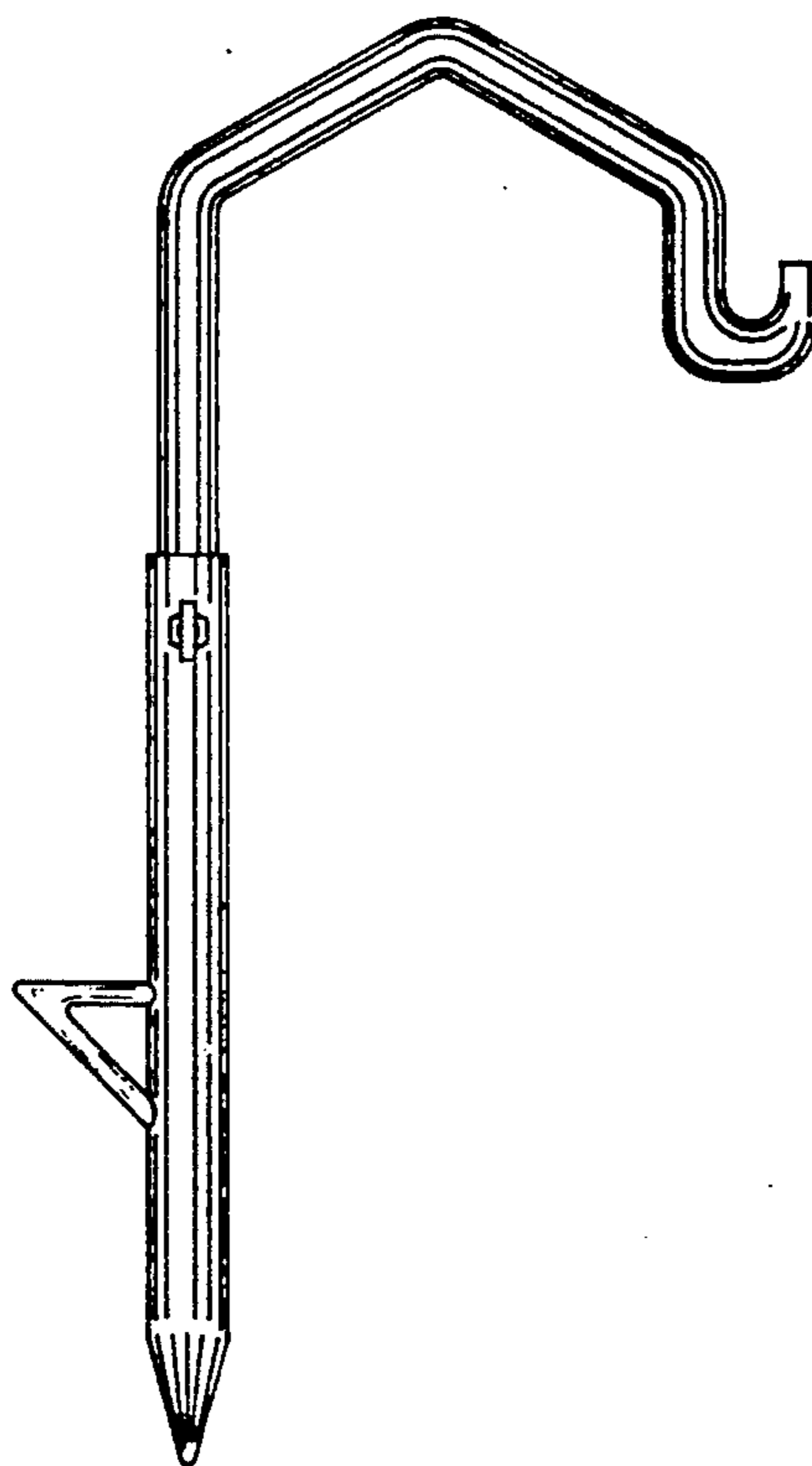

FIG. 1

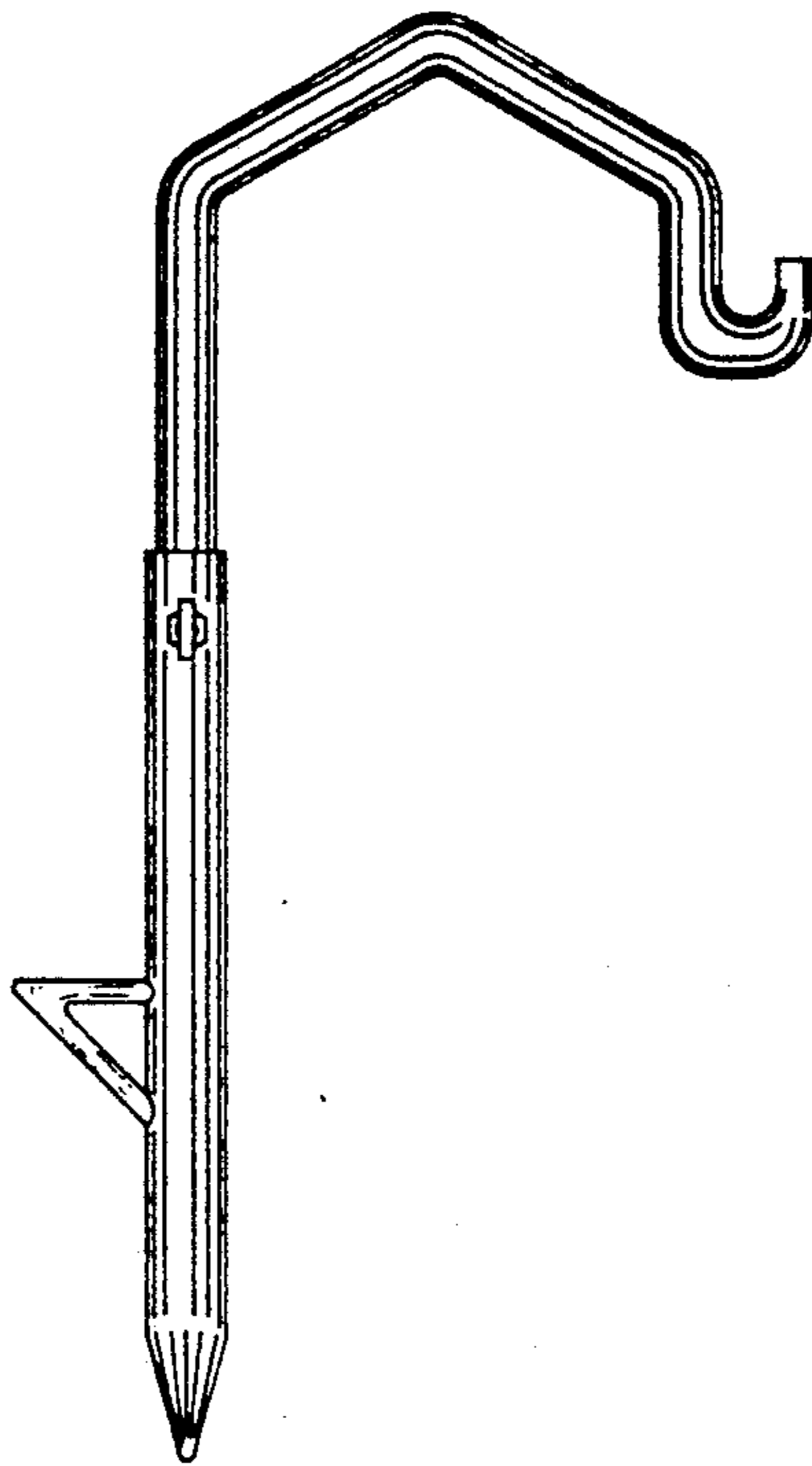

FIG. 2

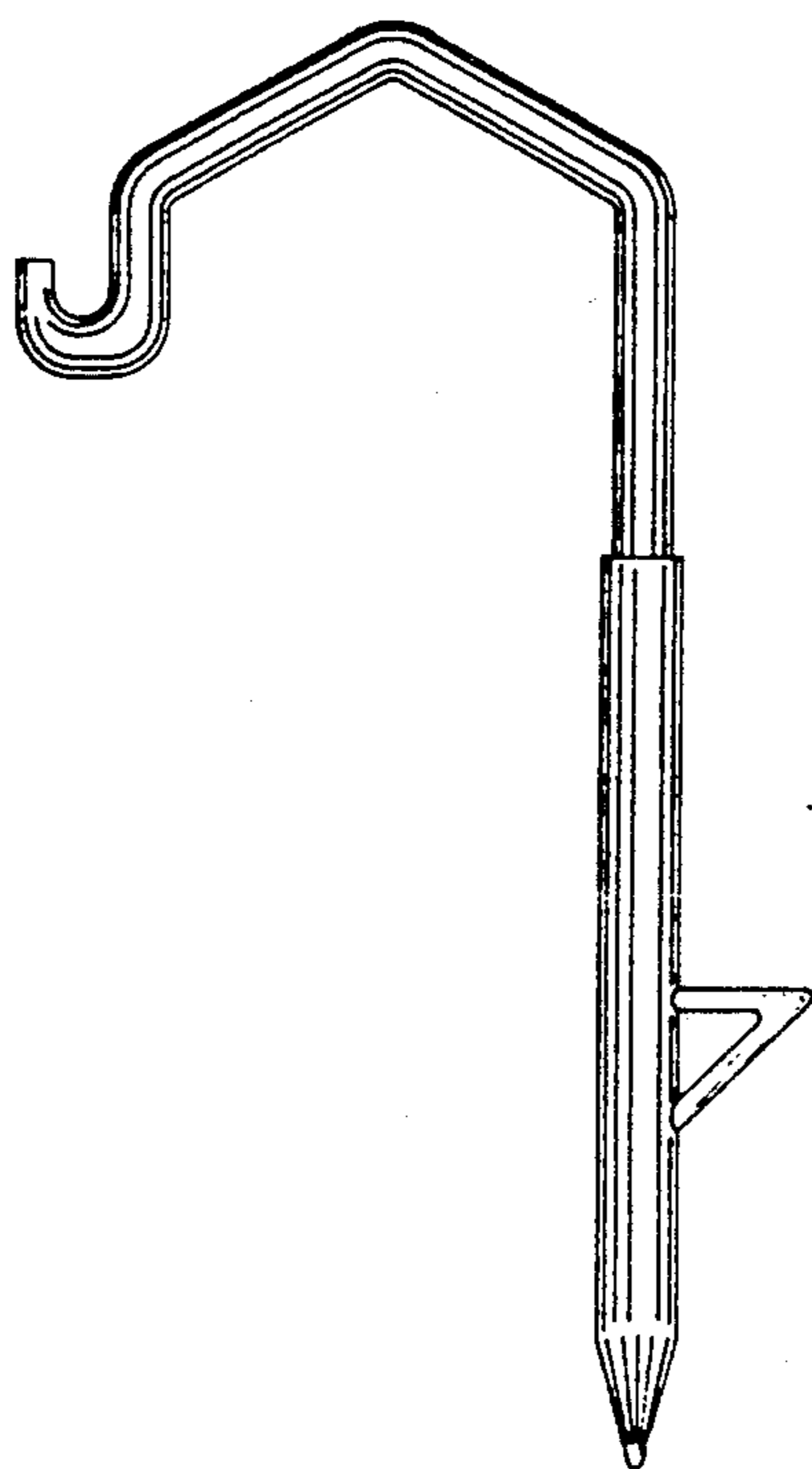

FIG. 3



FIG. 4



FIG. 5

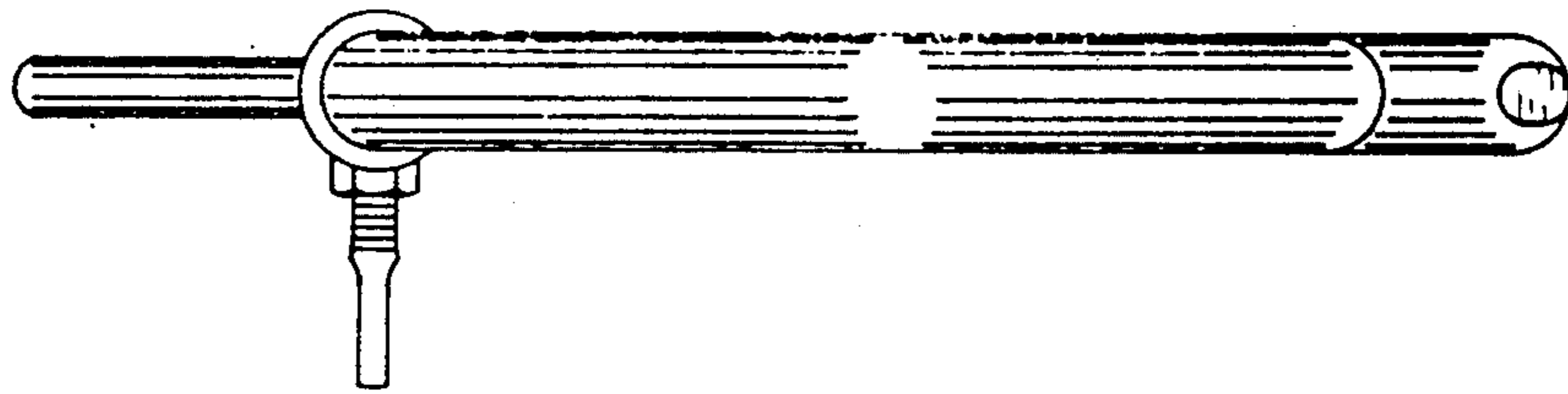

FIG. 6

