

[54] **OUTBOARD MOTOR CARRIER**

[76] **Inventor: Philip J. Greenberg, 20622 Superior St., Unit 6, Chatsworth, Calif. 91311**

[**] **Term: 14 Years**

[21] **Appl. No.: 495,214**

[22] **Filed: Mar. 19, 1990**

[52] **U.S. Cl. D12/317; D8/373**

[58] **Field of Search D12/317, 318; D8/349, D8/373; 248/641, 643, 642; 114/343**

[56] **References Cited**

U.S. PATENT DOCUMENTS

D. 259,228 5/1981 Fabian D8/373
2,808,218 10/1957 Steller D12/317

Primary Examiner—Kay H. Chin
Attorney, Agent, or Firm—Edward E. Roberts

[57] **CLAIM**

The ornamental design for an outboard motor carrier, as shown and described.

DESCRIPTION

FIG. 1 is a top, front and left side perspective view of an outboard motor carrier showing my new design; FIG. 2 is a left side elevational view thereof; FIG. 3 is a rear elevational view thereof; FIG. 4 is a right side elevational view thereof; and FIG. 5 is a bottom plan view thereof.

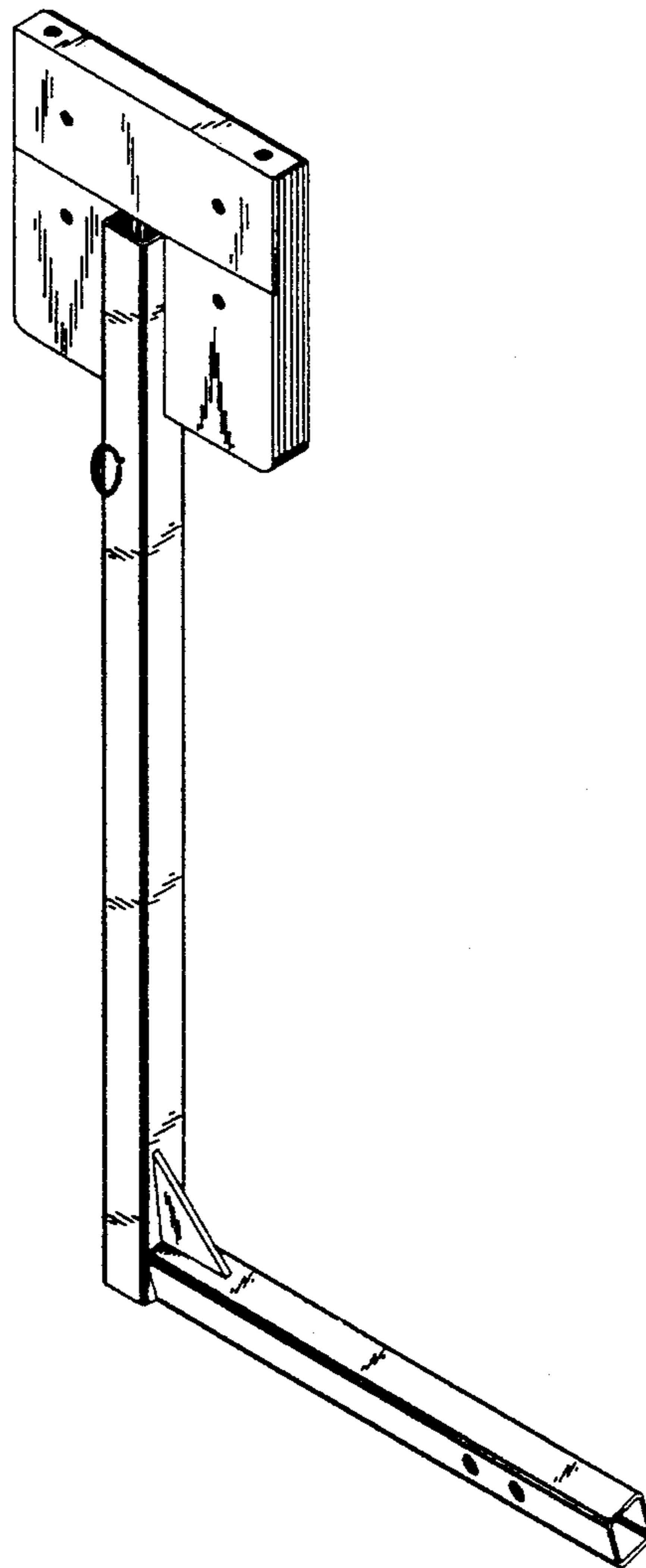

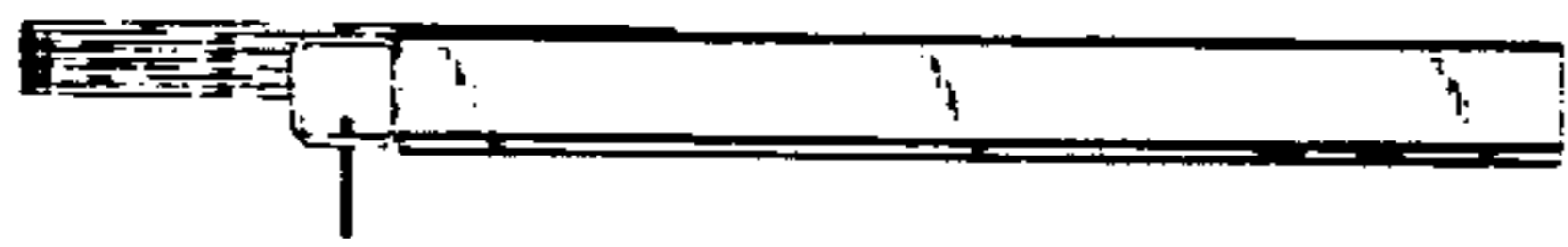

FIG. 5

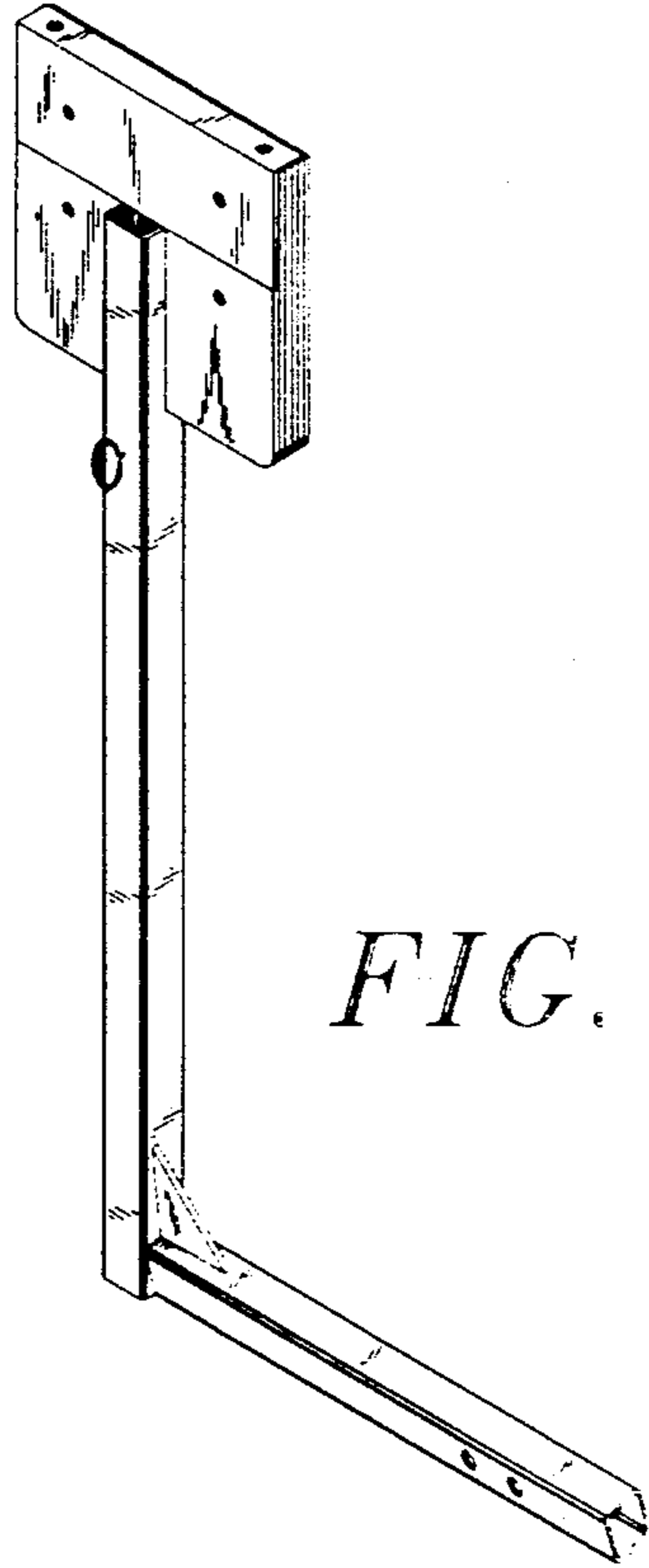

FIG. 1

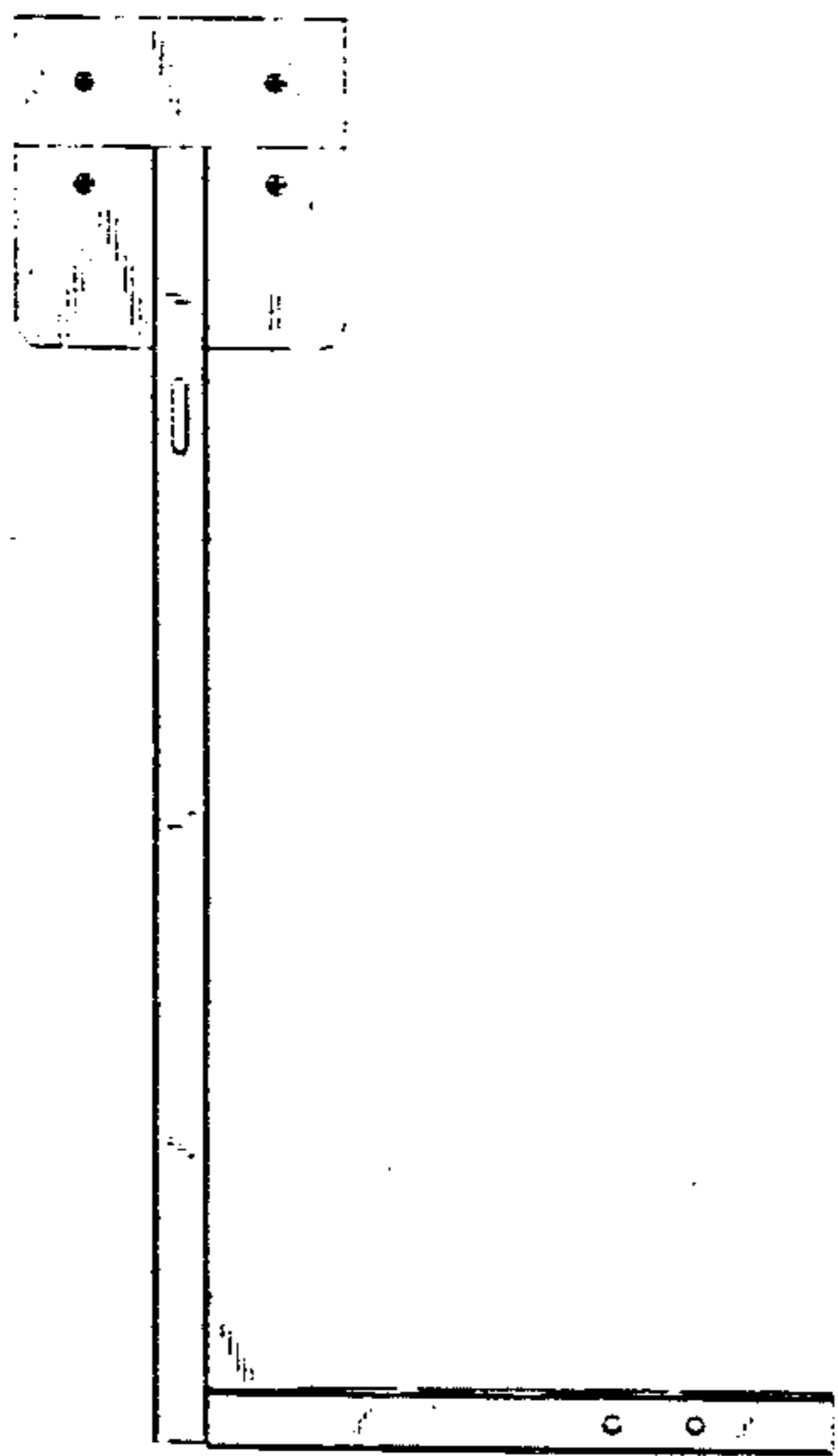

FIG. 2

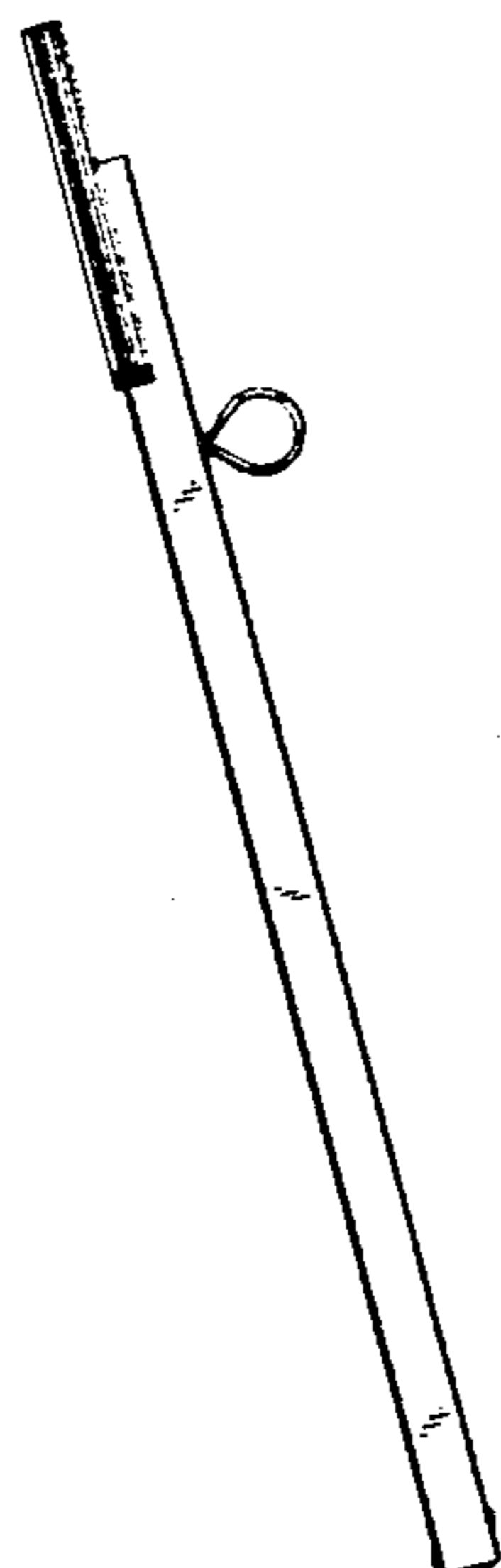

FIG. 3

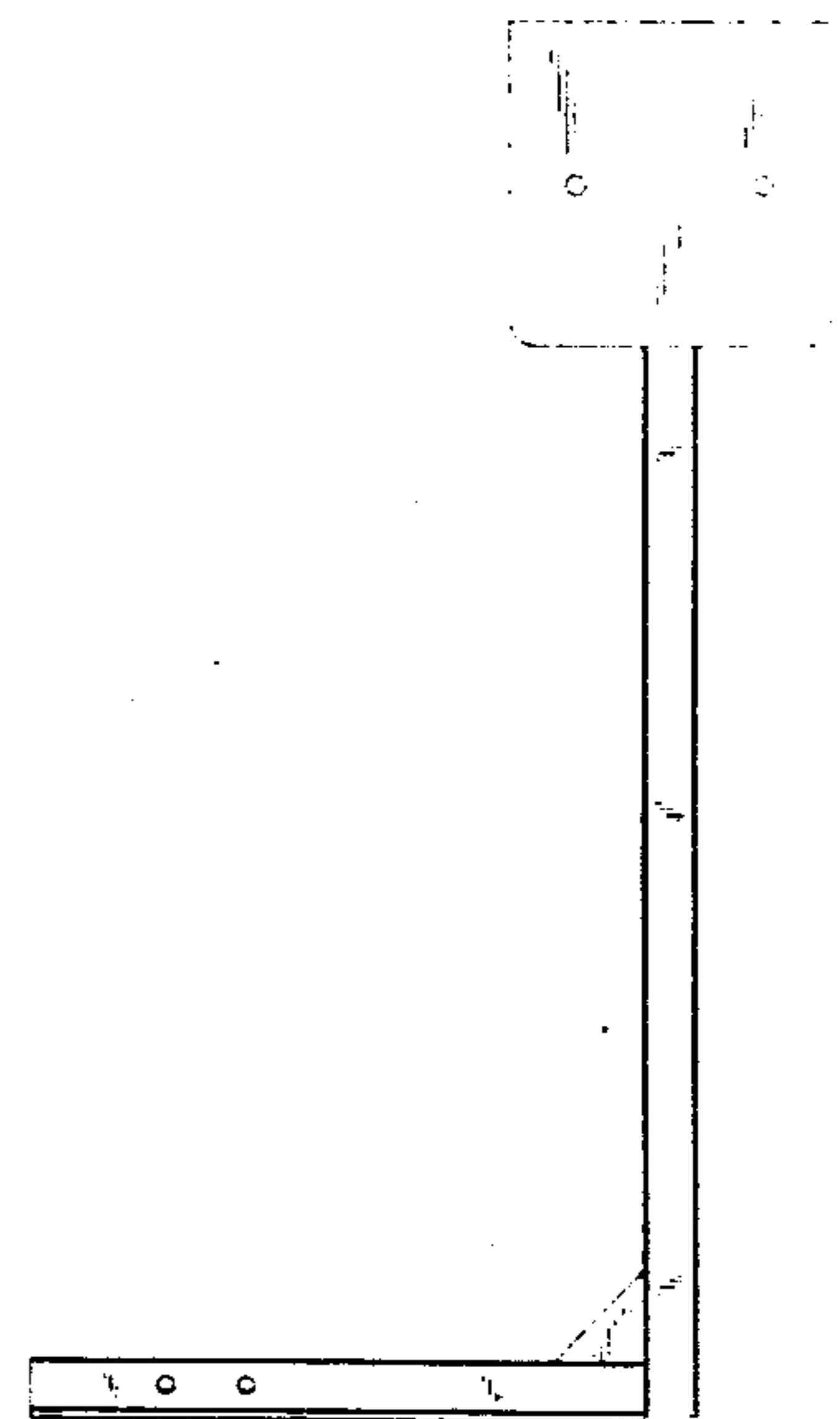

FIG. 4