

[54] **DRIVER FOR SCREWS OR THE LIKE**
[75] **Inventor: Albert Wan, Kowloon, Hong Kong**
[73] **Assignee: FEE TAT Plastic Factory Limited, Aberdeen, Hong Kong**
[**] **Term: 14 Years**
[21] **Appl. No.: 304,022**
[22] **Filed: Jan. 30, 1989**
[30] **Foreign Application Priority Data**
Aug. 12, 1988 [GB] United Kingdom 1052953
[52] **U.S. Cl. D8/68**
[58] **Field of Search D8/61, 62, 68; 81/54, 81/57.11, 57.13, 57.14, 429; 173/163, 170; 408/124, 125, 127**

3,869,942 3/1975 DeCaro 81/54
4,448,098 5/1984 Totsu 81/57.11
4,485,698 12/1984 Adman et al. 81/57.11
4,573,370 3/1986 Clemens 173/163

Primary Examiner—Nelson C. Holtje
Assistant Examiner—J. H. Musgrove
Attorney, Agent, or Firm—Cohen, Pontani & Lieberman

[57] **CLAIM**

The ornamental design for a driver for screws or the like, as shown.

DESCRIPTION

FIG. 1 is a top plan view of a driver for screws or the like showing my new design;
FIG. 2 is a right side elevational view;
FIG. 3 is a bottom plan view;
FIG. 4 is a left side elevational view;
FIG. 5 is a front elevational;
FIG. 6 is a rear elevational view;
FIG. 7 is a top, rear left side perspective view; and
FIG. 8 is a top right-front perspective view thereof.

[56] **References Cited**
U.S. PATENT DOCUMENTS
D. 302,786 8/1989 Fushiya et al. D8/68
D. 315,282 3/1991 Schmidt et al. D8/68

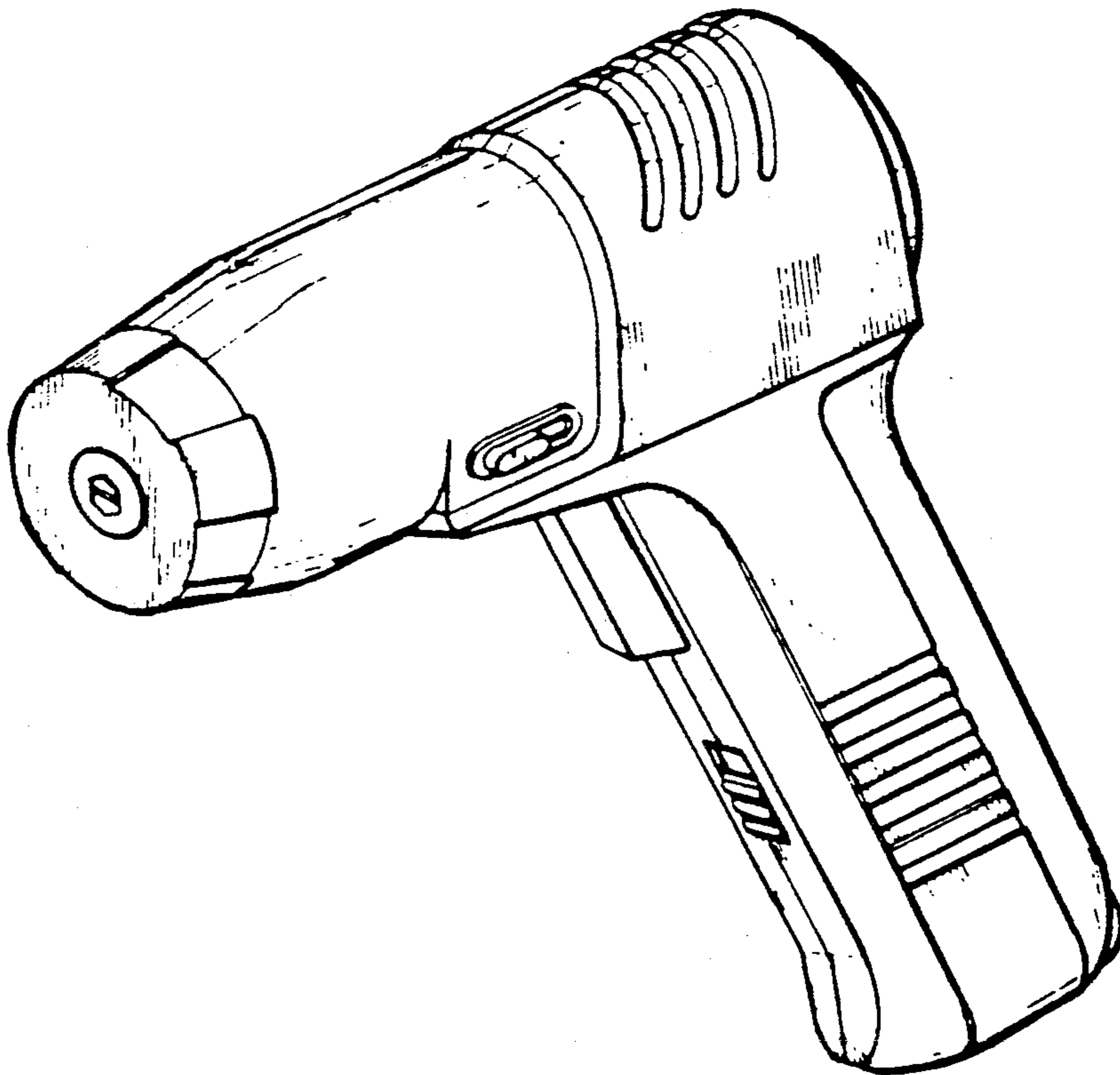

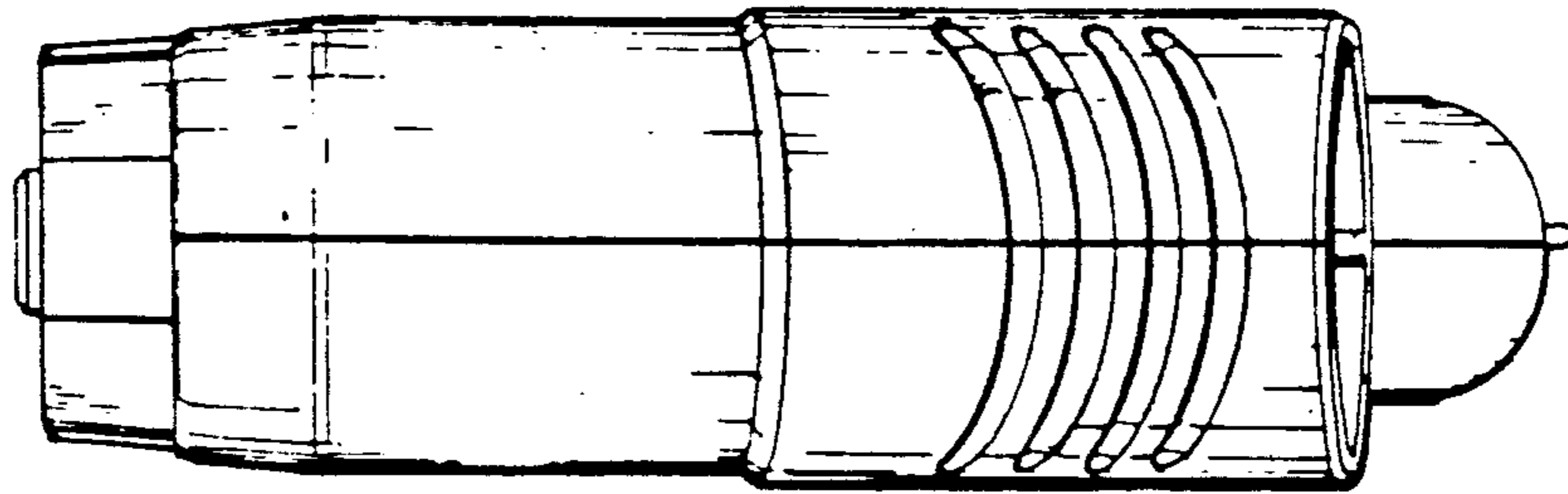

FIG. 1

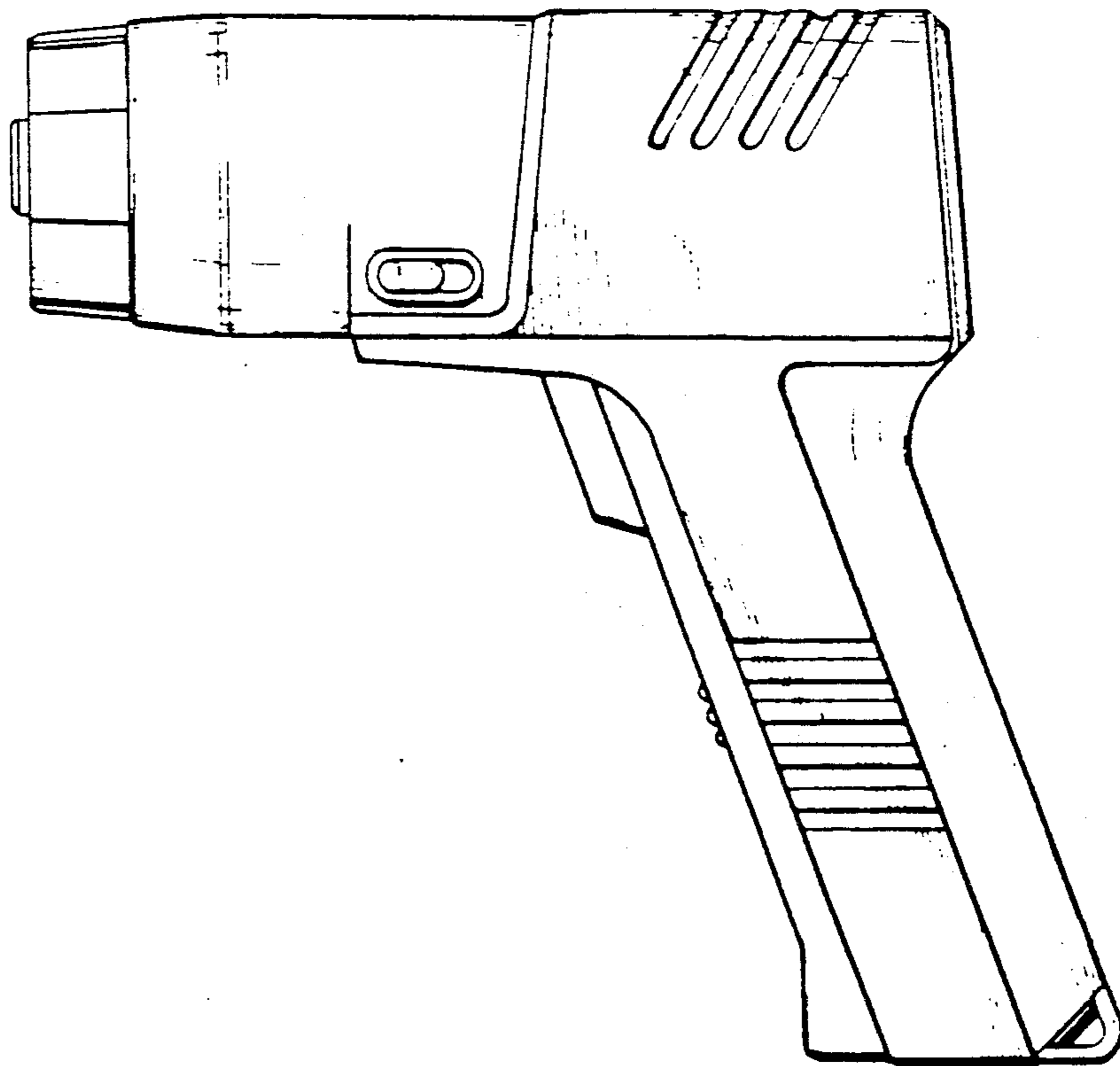

FIG. 2

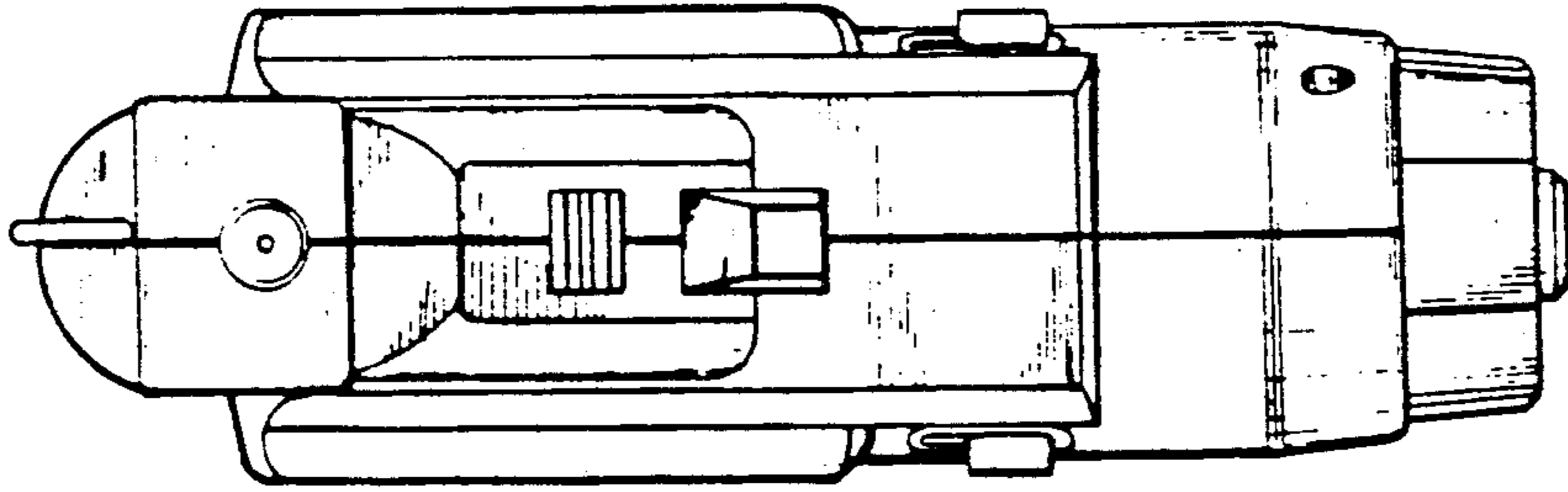

FIG. 3

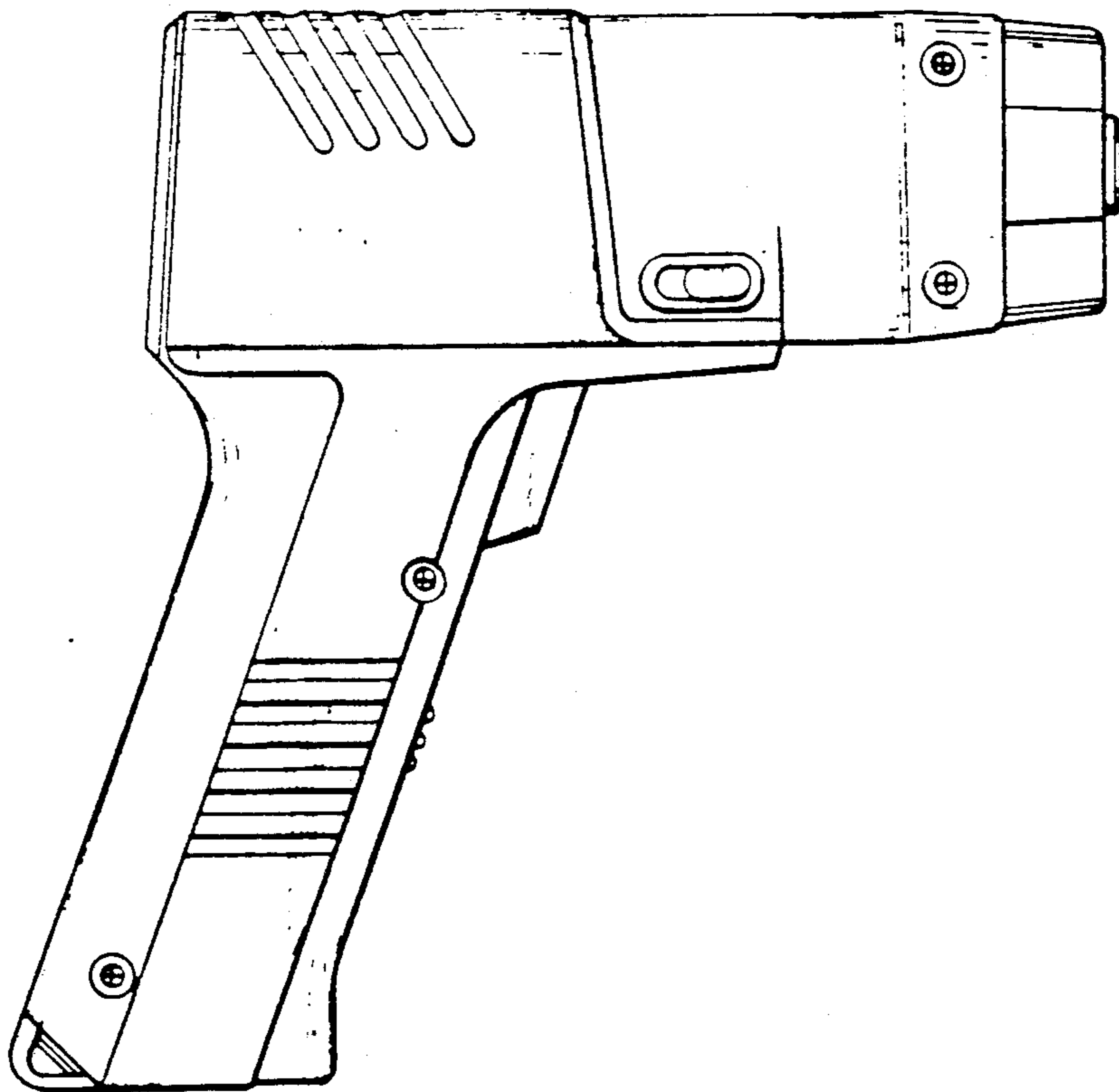

FIG. 4

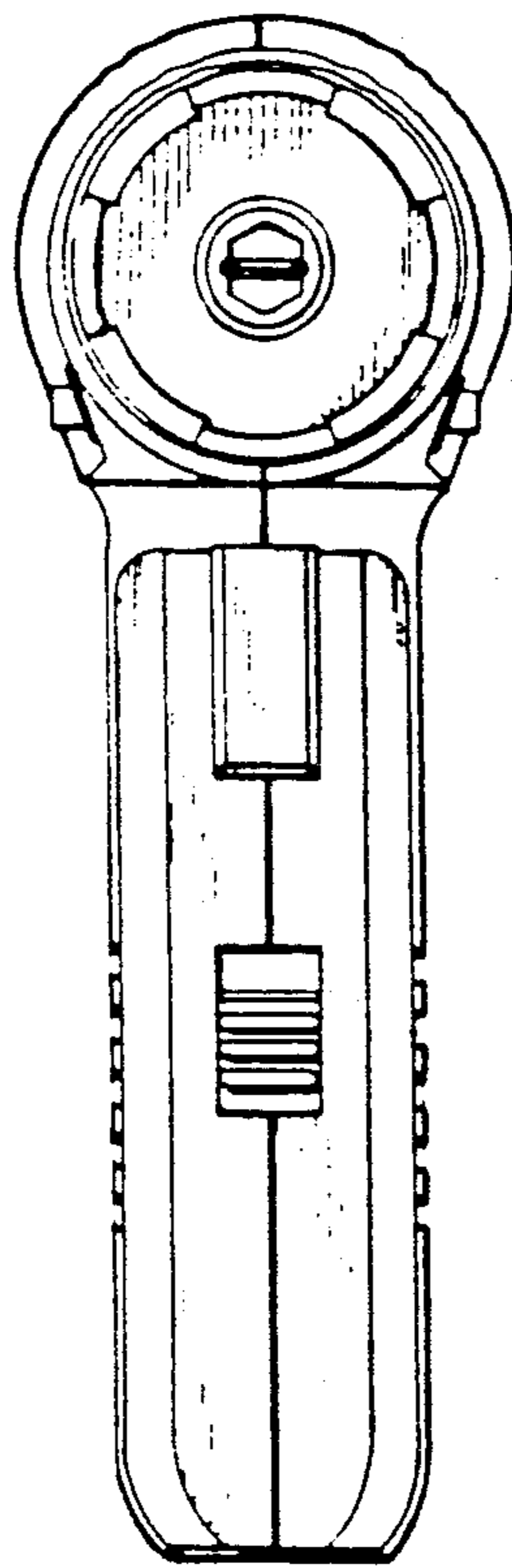

FIG. 5

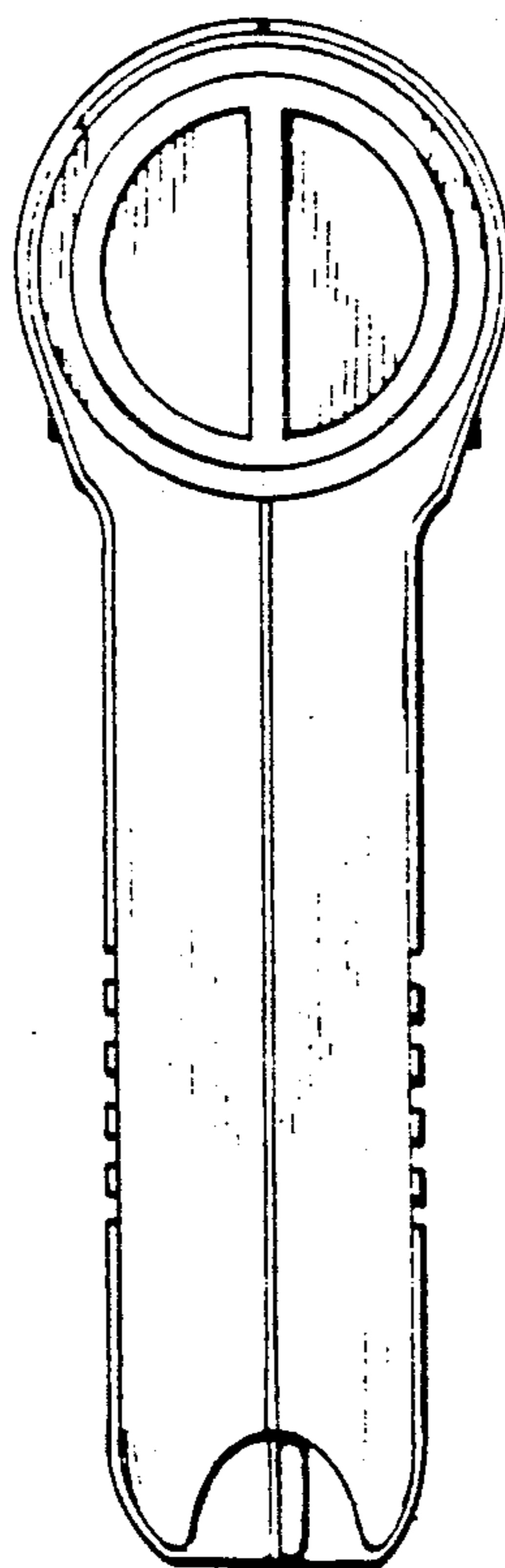

FIG. 6

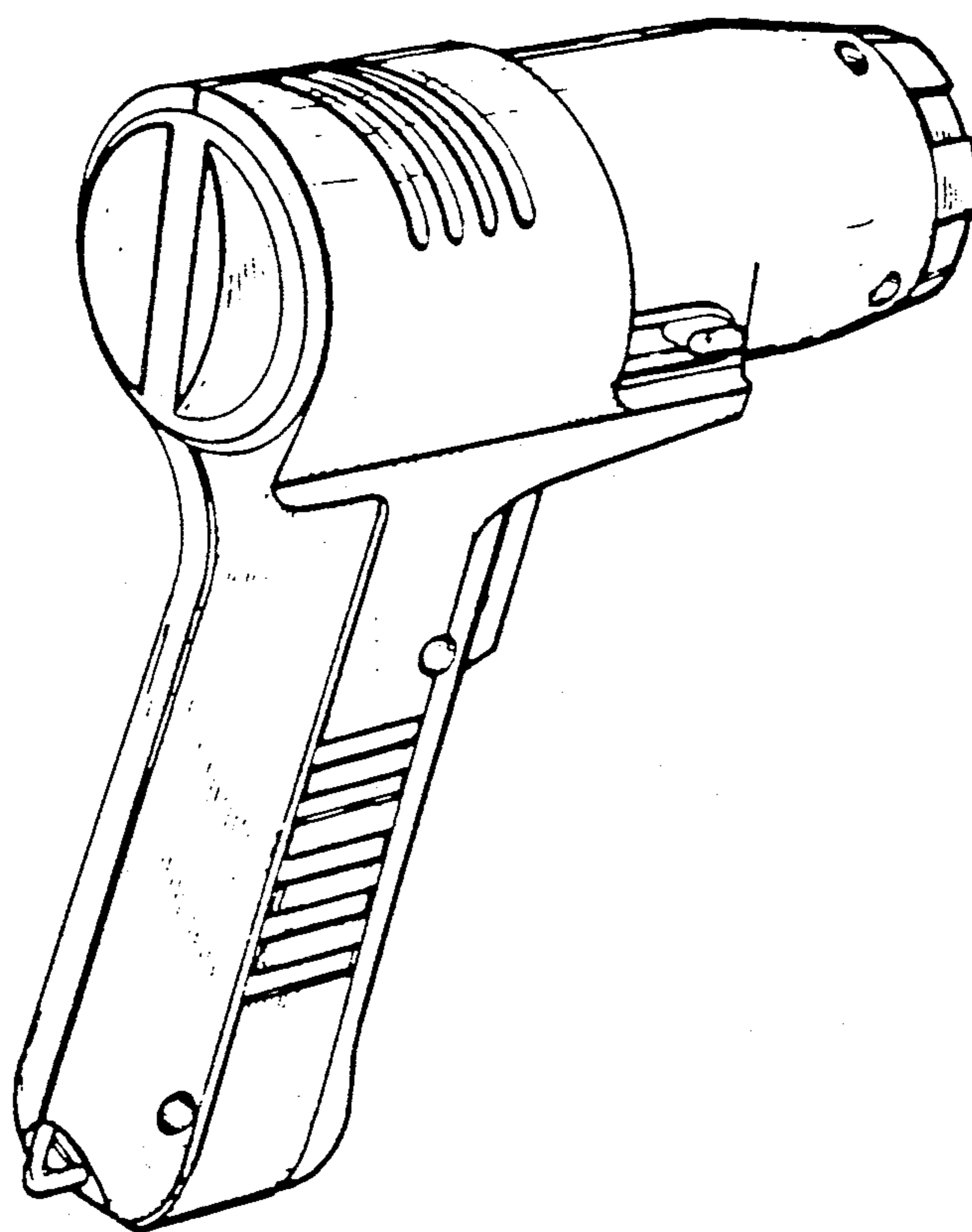

FIG. 7

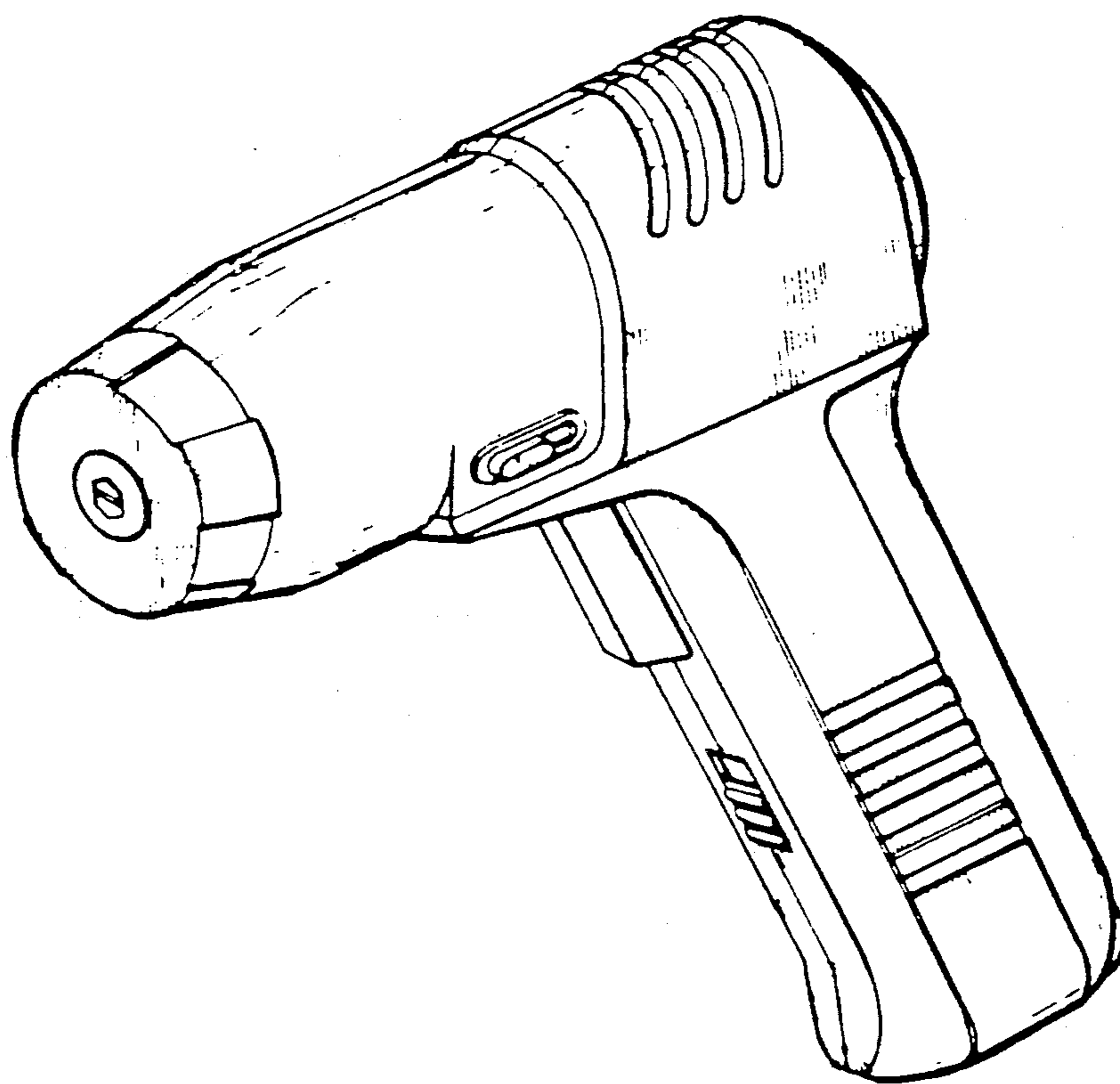

FIG. 8