

[54] OVERHEAD LUGGAGE RACK OR THE LIKE

[56] References Cited

[75] Inventor: Heinz Wirth, Aalen-Oberalfingen, Fed. Rep. of Germany

U.S. PATENT DOCUMENTS

D. 115,255	6/1939	Taylor	D6/566
D. 242,888	1/1977	Mazie et al.	D6/566
D. 282,995	3/1986	Beverly	D6/566
2,887,802	5/1959	Burmeister	211/90 X
4,122,955	10/1978	Celms	211/126

[73] Assignee: Eisen- und Drahtwerk Erlau Aktiengesellschaft, Aalen, Fed. Rep. of Germany

Primary Examiner—Brian N. Vinson
Attorney, Agent, or Firm—Robert W. Becker & Associates

[**] Term: 14 Years

[57] CLAIM

[21] Appl. No.: 398,250

The ornamental design for a overhead luggage rack or the like, as shown and described.

[22] Filed: Aug. 24, 1989

DESCRIPTION

[30] Foreign Application Priority Data

Feb. 24, 1989 [DE] Fed. Rep. of Germany ... 8901480[U]

[52] U.S. Cl. D6/566; D6/462

[58] Field of Search D6/552-553, D6/566-567, 574, 396, 449, 462, 524-525, 511; 211/13, 30, 32, 42, 86-88, 90, 126, 134, 181; 108/28, 42, 59, 149

FIG. 1 is a top, front, and left side perspective view of an overhead luggage rack or the like showing my new design;
FIG. 2 is a front elevational view thereof;
FIG. 3 is a top plan view thereof;
FIG. 4 is a rear elevational view thereof;
FIG. 5 is a bottom plan view thereof;
FIG. 6 is a left side elevational view thereof; and
FIG. 7 is a right side elevational view thereof.

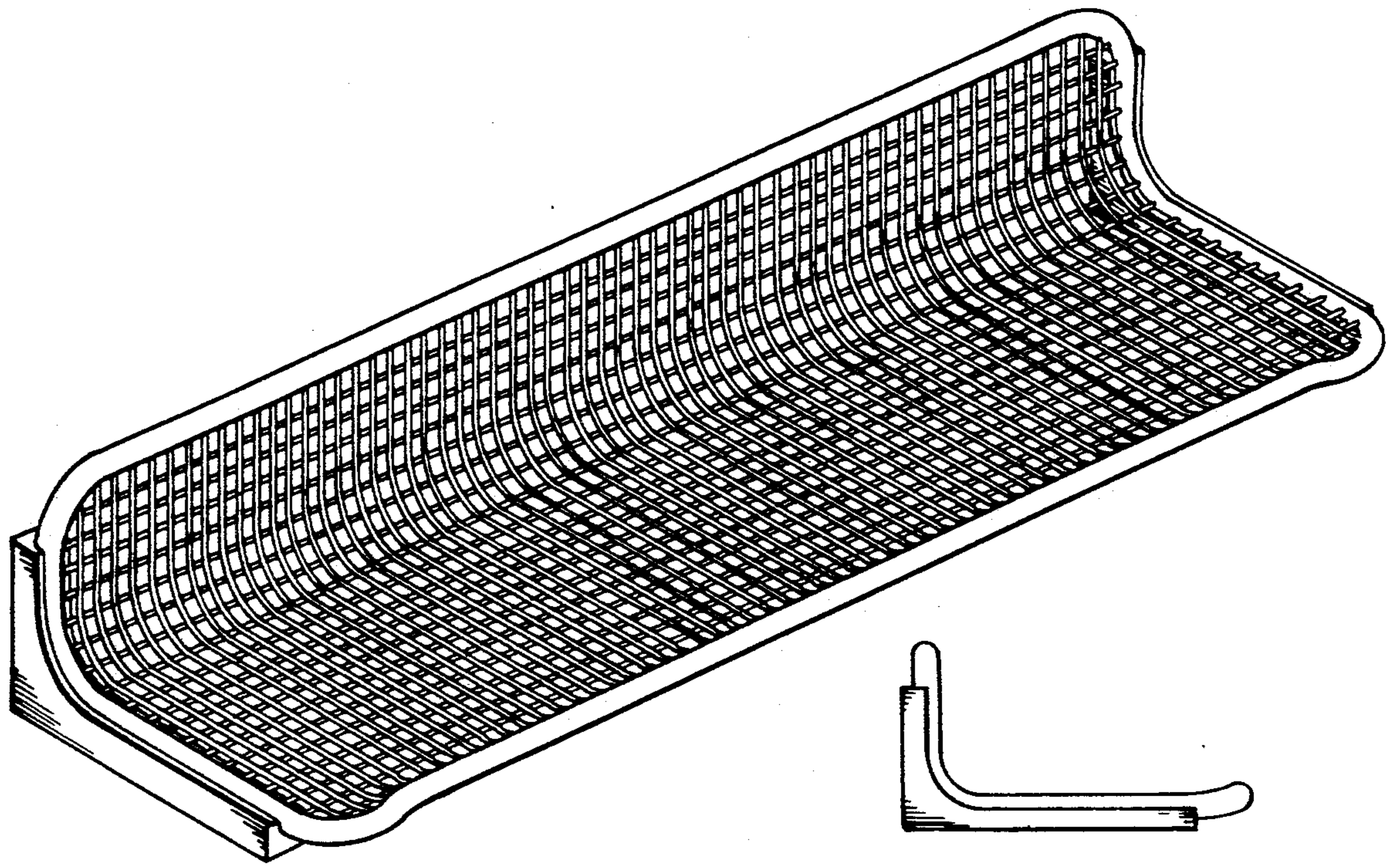

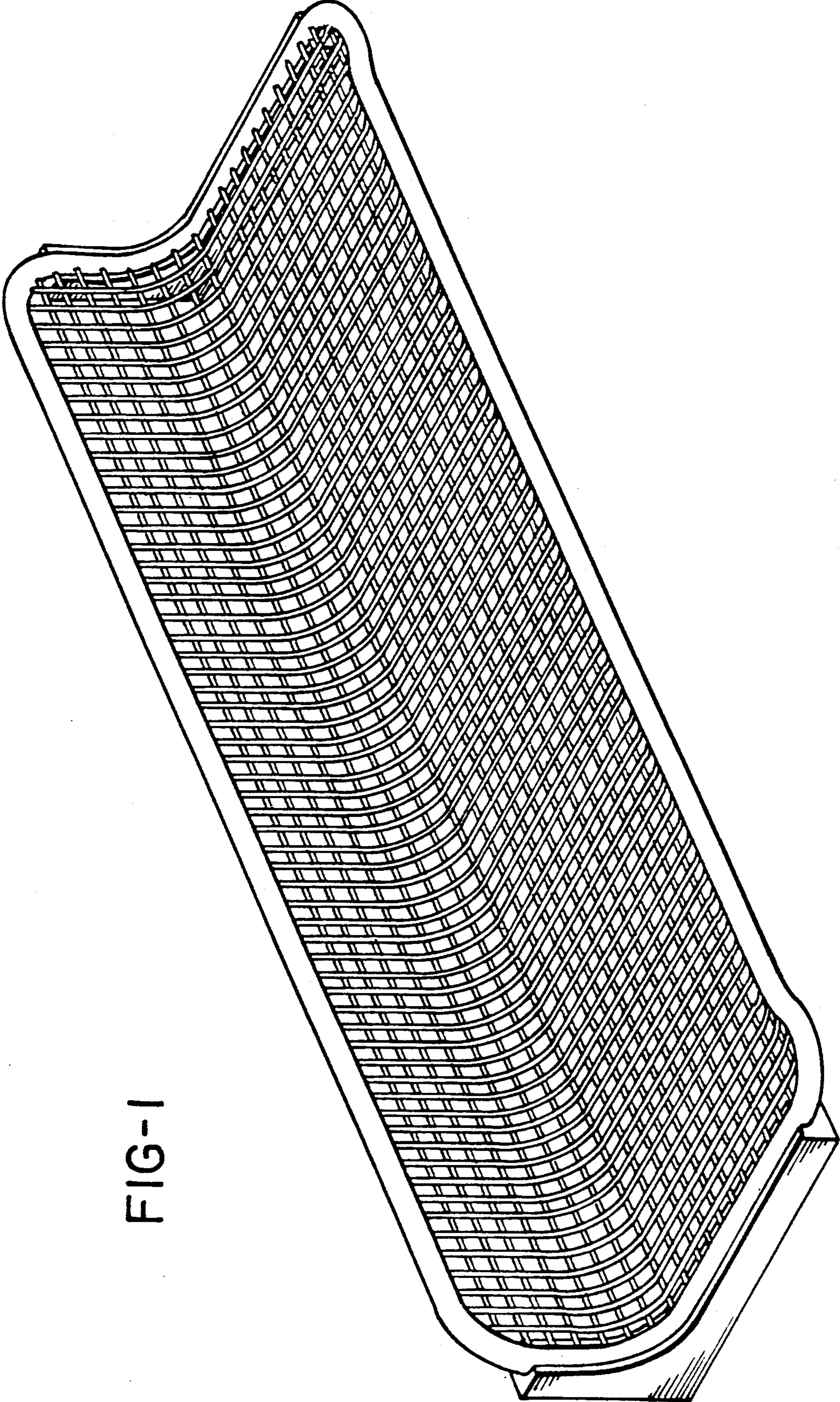

FIG-1

FIG-2

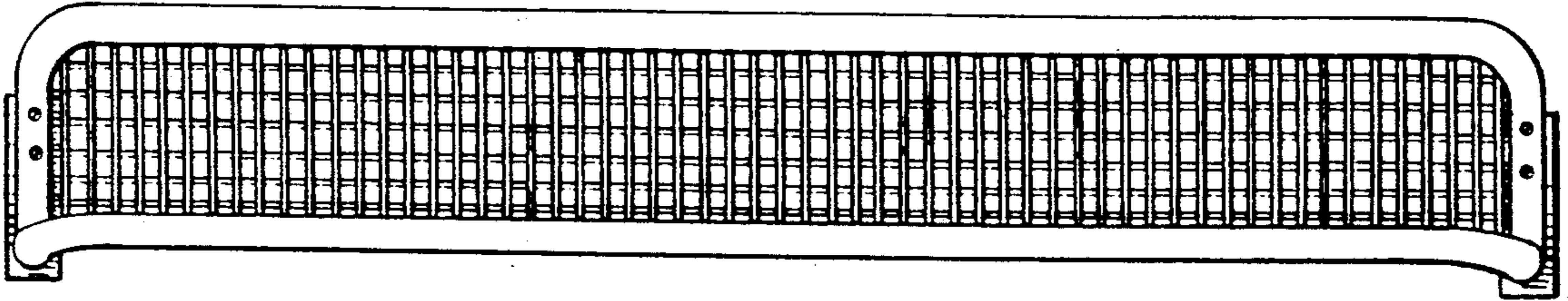

FIG-3

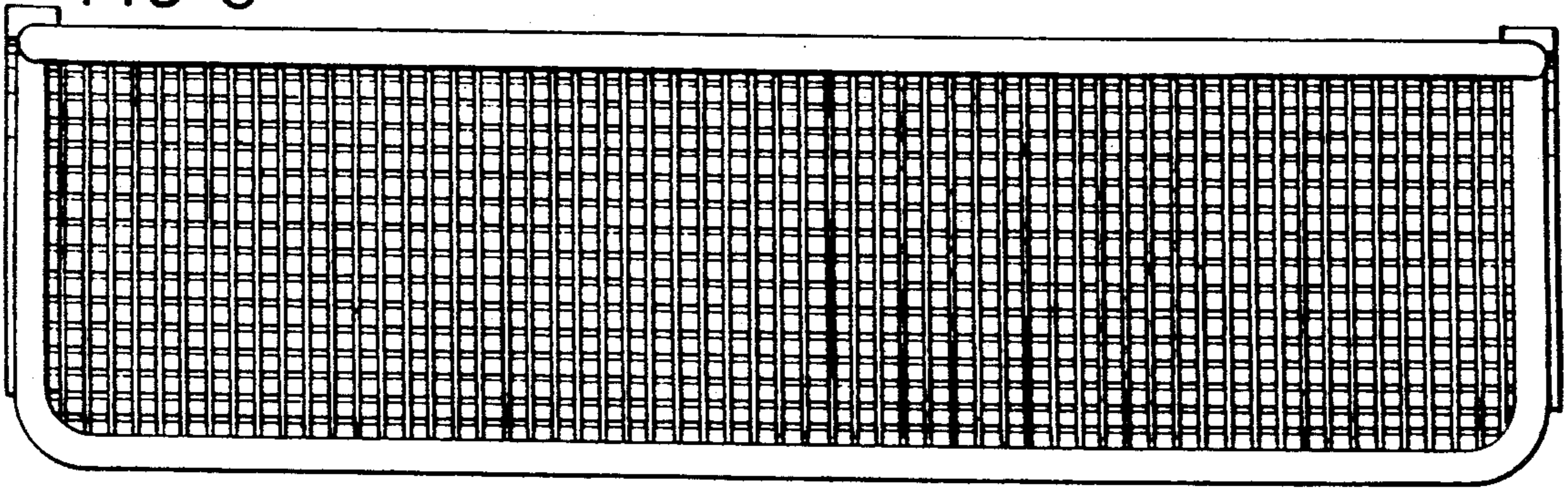

FIG-4

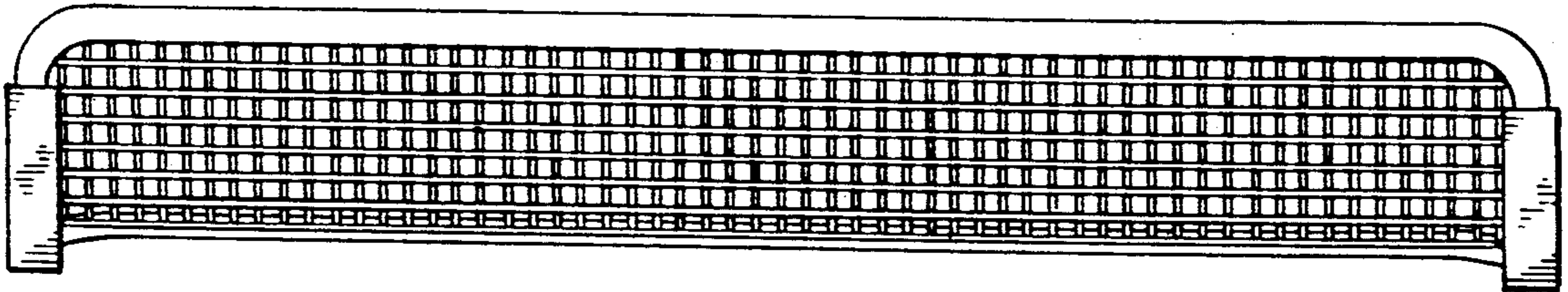

FIG-5

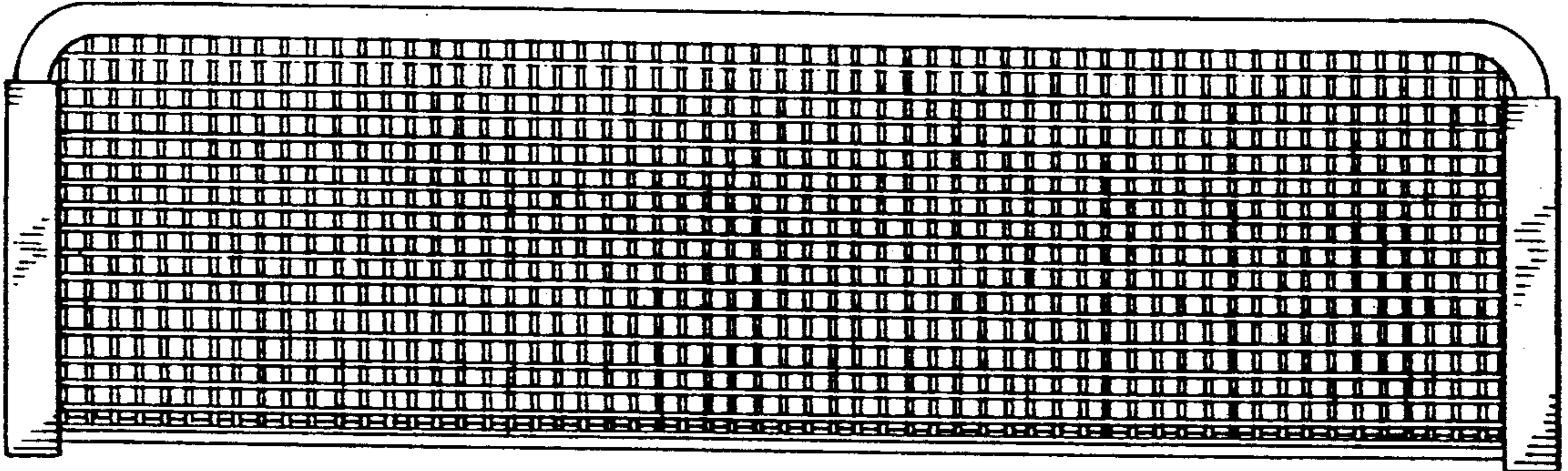

FIG-6

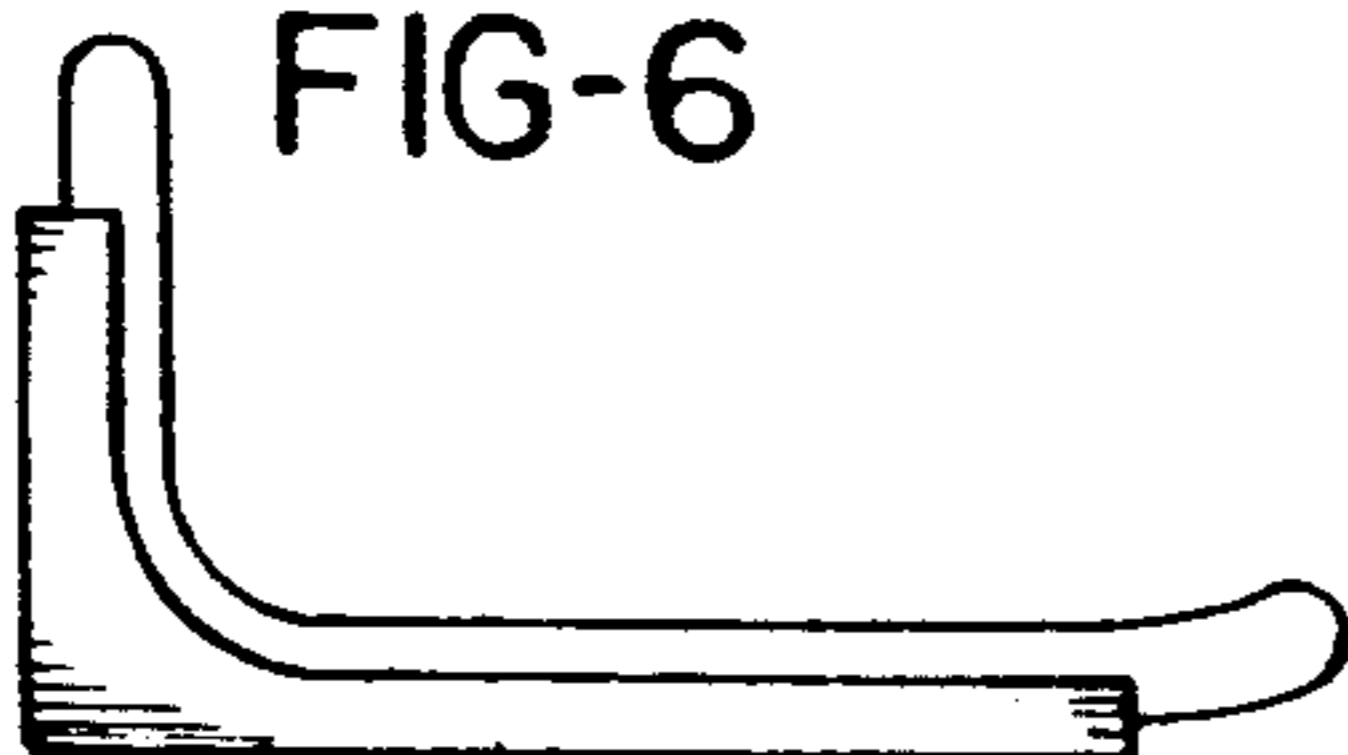

FIG-7

