

[54] PROPELLER GUARD FOR BOAT MOTOR

[75] Inventor: Rodney Reeves, Ocean Springs, Miss.

[73] Assignee: Glenn F. Mattina, Ocean Springs, Miss.

[\*\*] Term: 14 Years

[21] Appl. No.: 447,879

[22] Filed: Dec. 7, 1989

[52] U.S. Cl. .... D15/4; 440/72

[58] Field of Search ..... D12/70; D15/4, 5; 440/71-72, 107, 67; 416/247 A

[56] References Cited

U.S. PATENT DOCUMENTS

- 1,620,129 3/1927 Peterson .
- 2,244,217 6/1941 Pries .
- 2,355,842 8/1944 Arado .
- 2,470,874 5/1949 Sidney .
- 2,983,246 5/1961 Manley .

- 3,802,377 4/1974 Porter et al. .
- 3,889,624 6/1975 Balias ..... 440/72
- 4,078,516 3/1978 Balias .

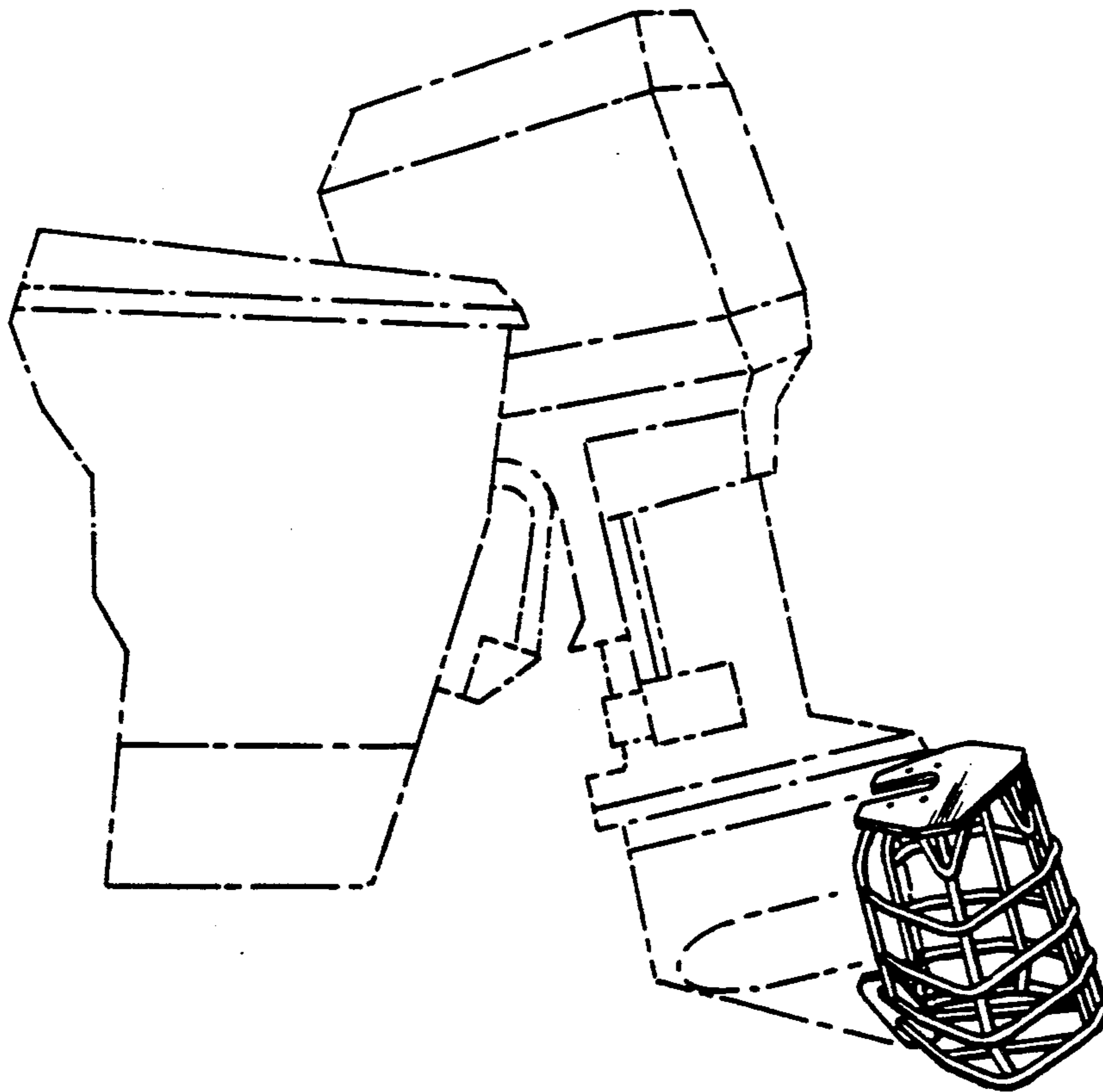
Primary Examiner—A. Hugo Word  
Assistant Examiner—R. Seifert  
Attorney, Agent, or Firm—Jones, Askew & Lunsford

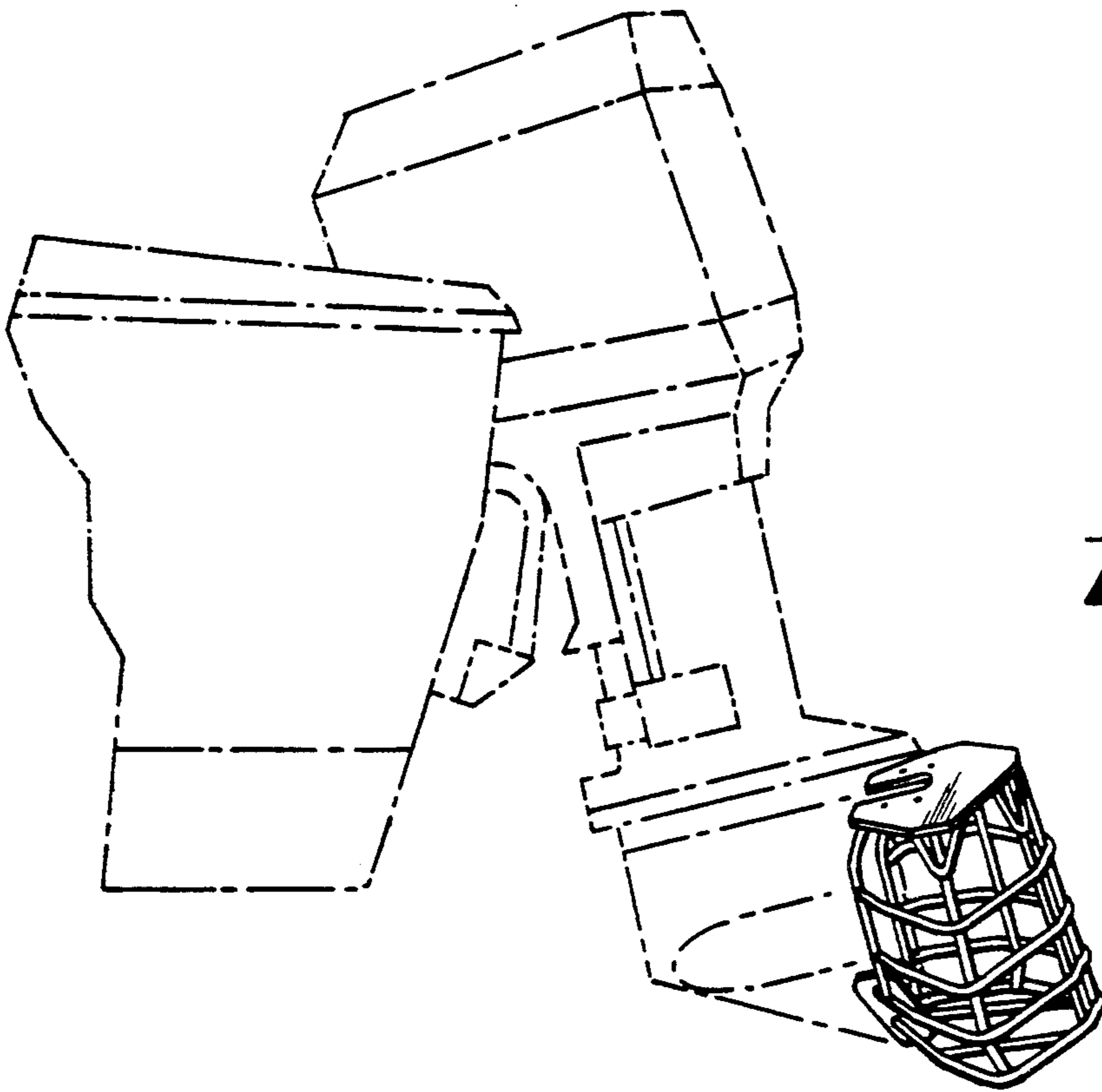
[57] CLAIM

The ornamental design for a propeller guard for boat motor, as shown and described.

DESCRIPTION

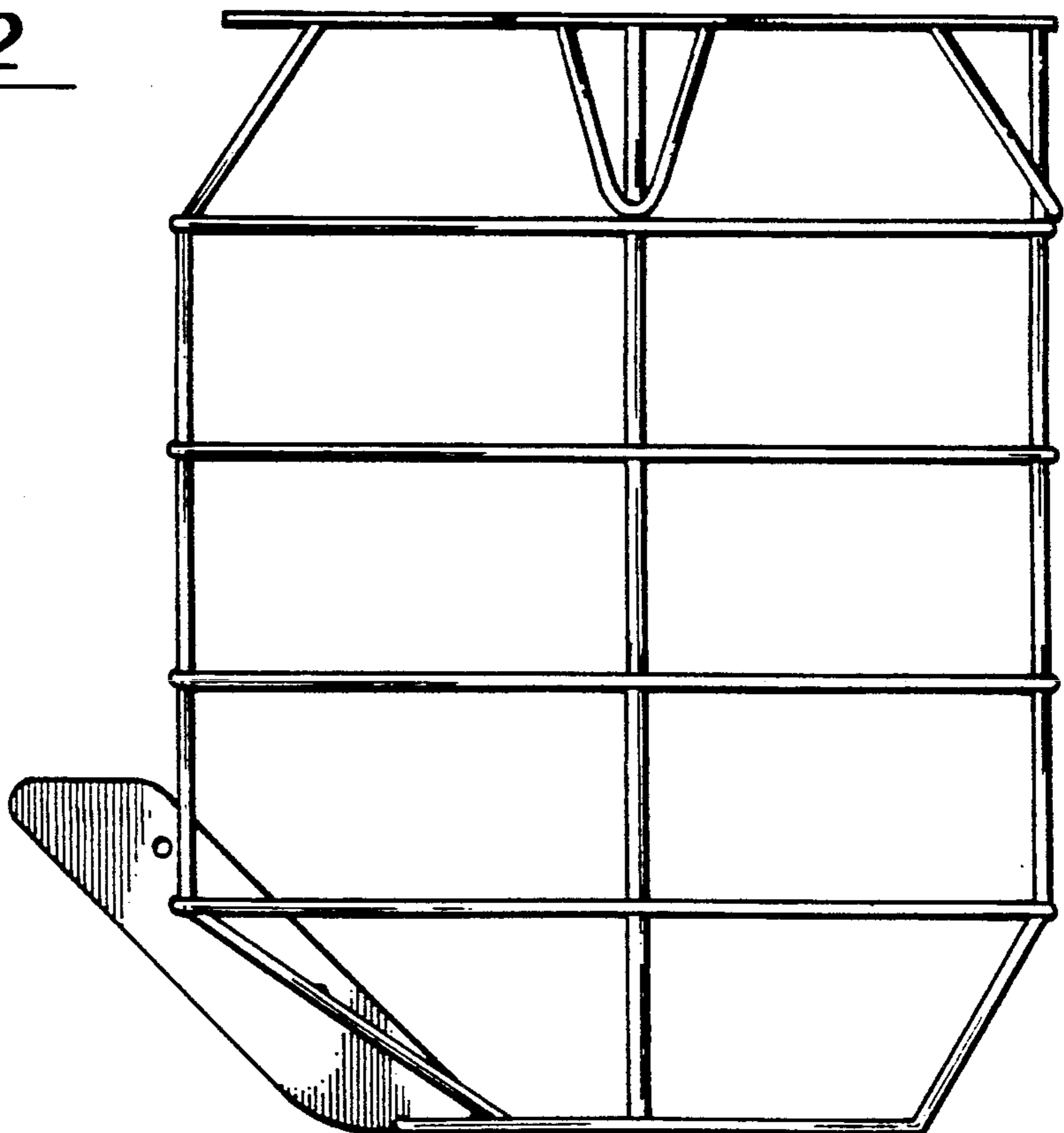
FIG. 1 is a perspective view of a propeller guard for boat motor showing my new design; FIG. 2 is a side elevational view; FIG. 3 is a top plan view; FIG. 4 is a front elevational view; FIG. 5 is a rear elevational view; and FIG. 6 is a bottom plan view. The broken line showing of an outboard motor and boat hull in FIG. 1 is for illustrative purposes only and forms no part of the claimed design.



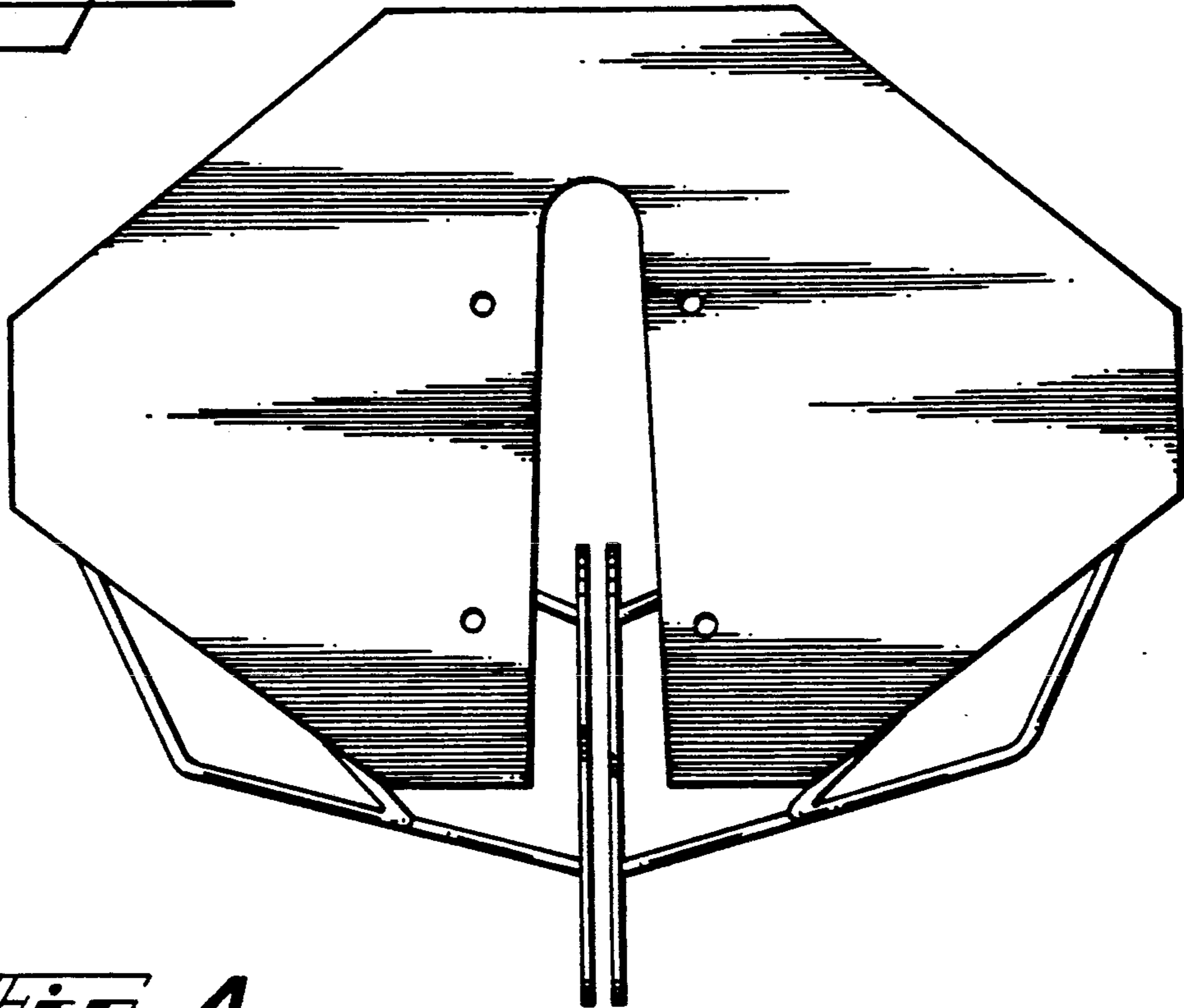


*Fig. 1*

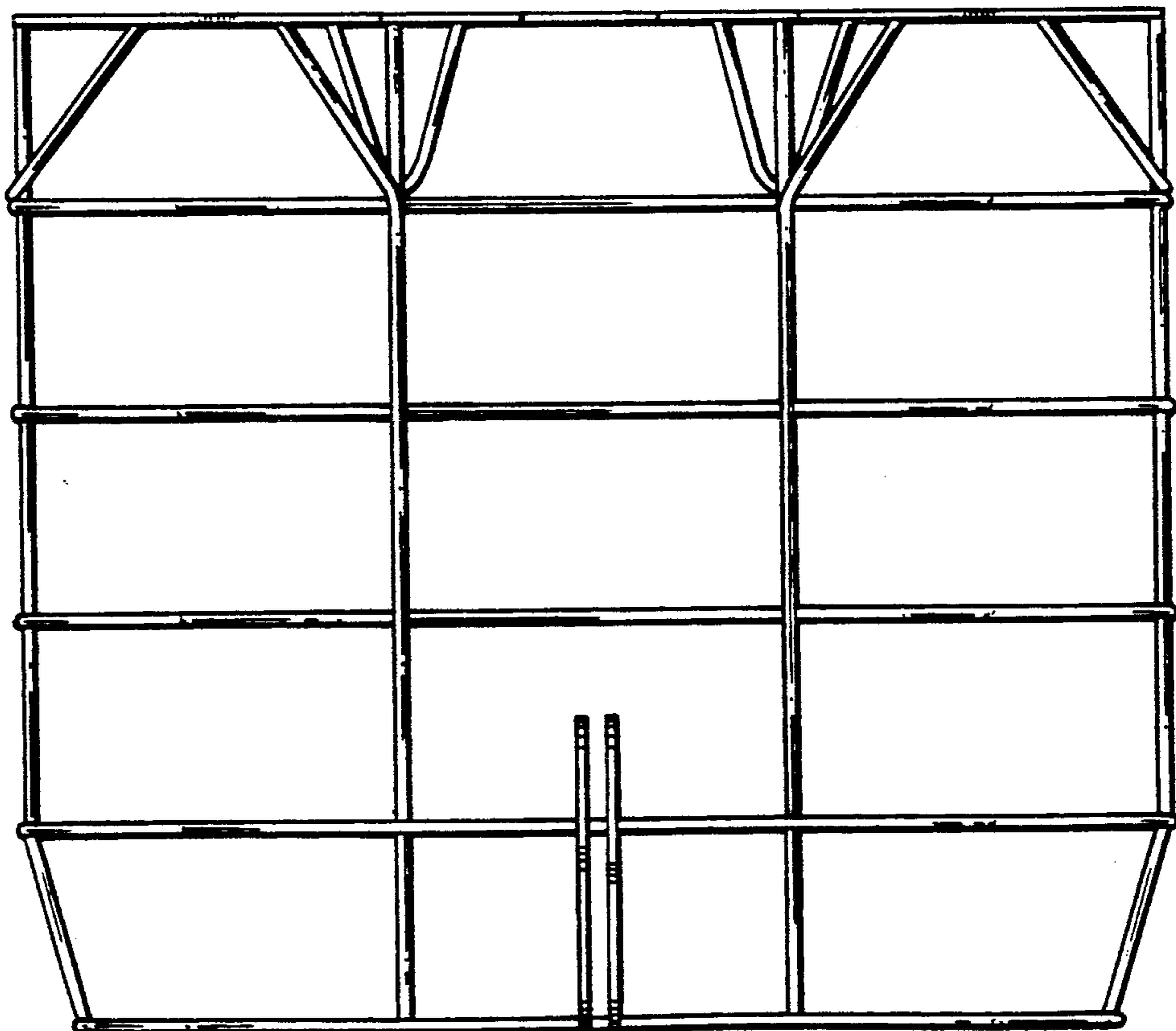
*Fig. 2*

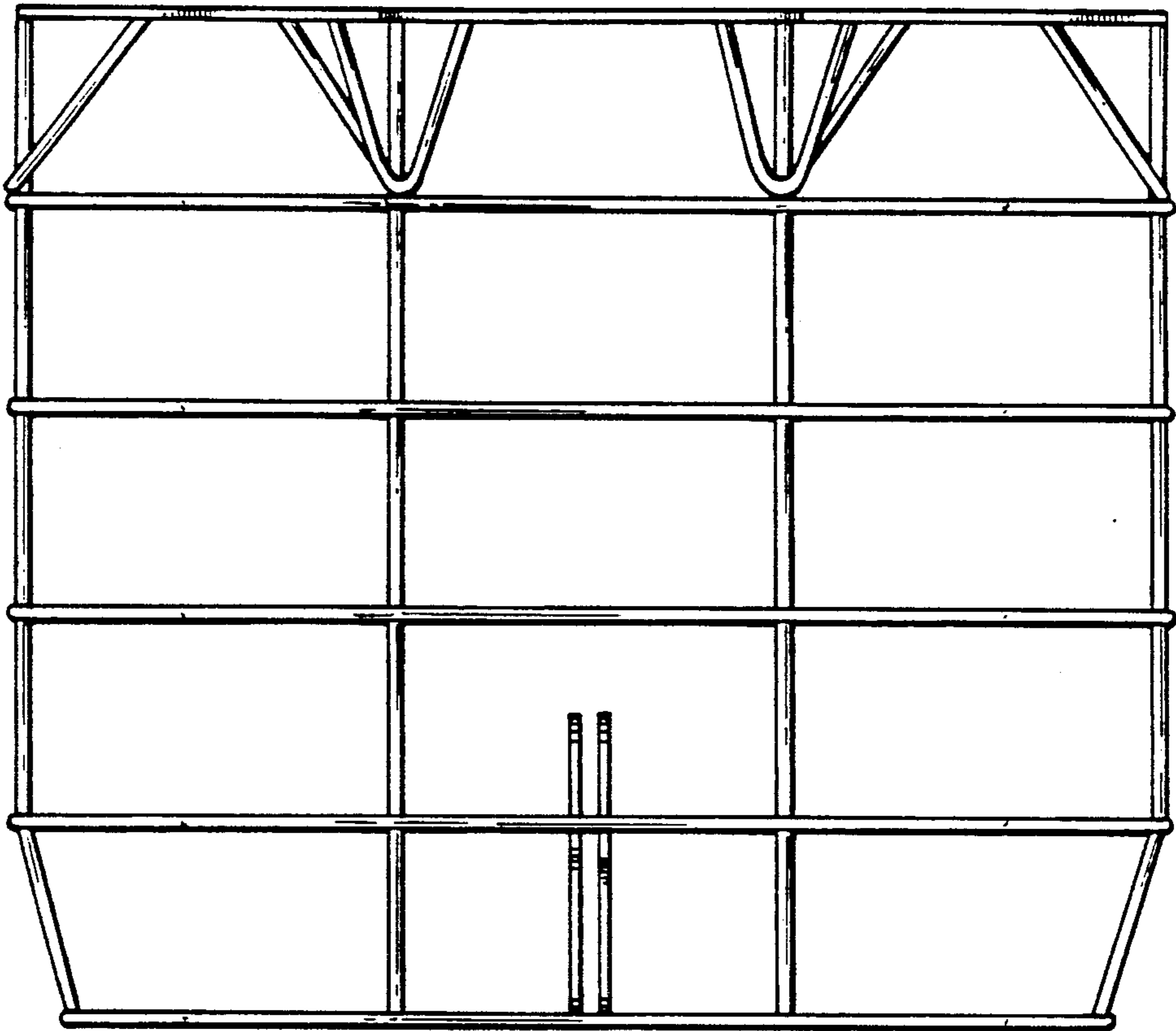


**Fig. 3**

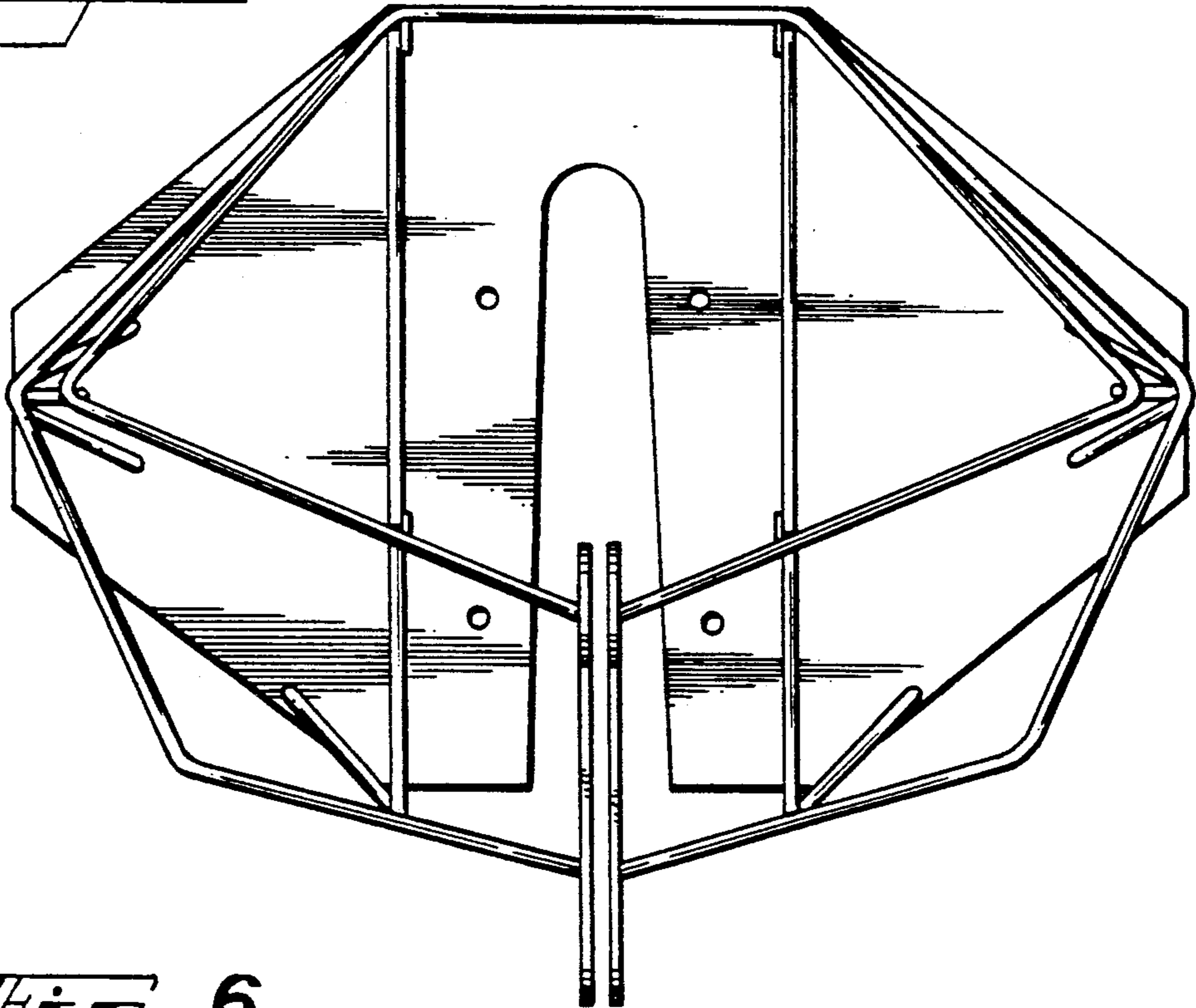


**Fig. 4**





**Fig. 5**



**Fig. 6**