

[54] **SPEED BOAT**

[75] **Inventor: Arthur E. Carlson, Cypress, Calif.**

[73] **Assignee: Glastron, Inc., New Braunfels, Tex.**

[\*\*] **Term: 14 Years**

[21] **Appl. No.: 450,016**

[22] **Filed: Dec. 13, 1989**

[52] **U.S. Cl. .... D12/300; D12/314**

[58] **Field of Search ..... D12/300, 310, 311, 312,  
D12/313, 314, 315, 318; 114/56, 291**

[56] **References Cited**

**U.S. PATENT DOCUMENTS**

- D. 190,400 5/1961 Tritt ..... D12/314
- D. 301,711 6/1989 Allbritton ..... D12/300

- D. 313,220 12/1990 Winn, Jr. et al. .... D12/315
- 4,827,862 5/1989 Enriquez ..... D12/300

*Primary Examiner—Kay H. Chin*

*Attorney, Agent, or Firm—Merchant, Gould, Smith,  
Edell, Welter & Schmidt*

[57] **CLAIM**

The ornamental design for a speed boat, as shown and described.

**DESCRIPTION**

FIG. 1 is a top and rear perspective view of a speed boat showing my new design;

FIG. 2 is a left side elevational view thereof, the right side view being a mirror image of that shown;

FIG. 3 is a top plan view thereof;

FIG. 4 is a front elevational view thereof; and

FIG. 5 is a rear elevational view thereof.

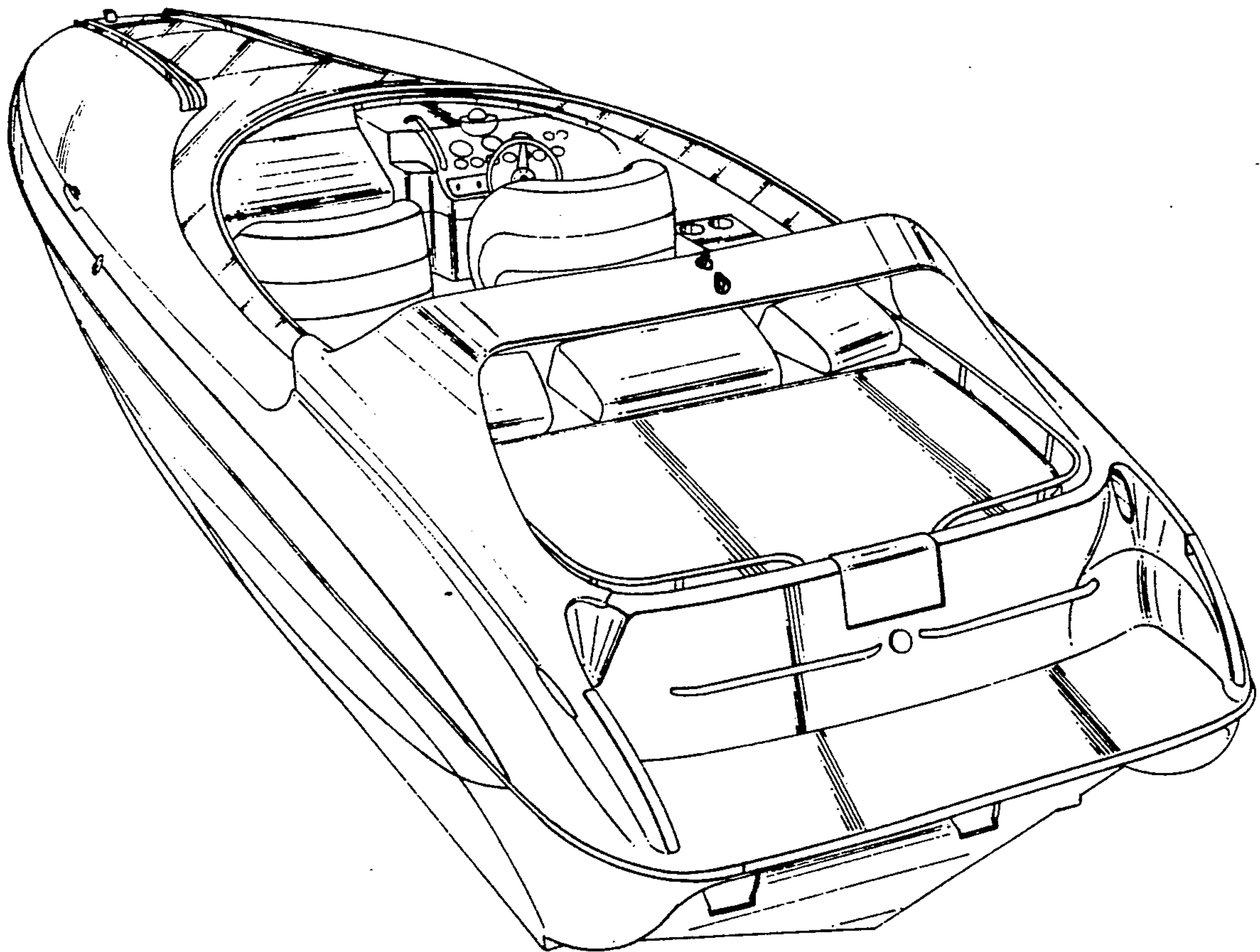
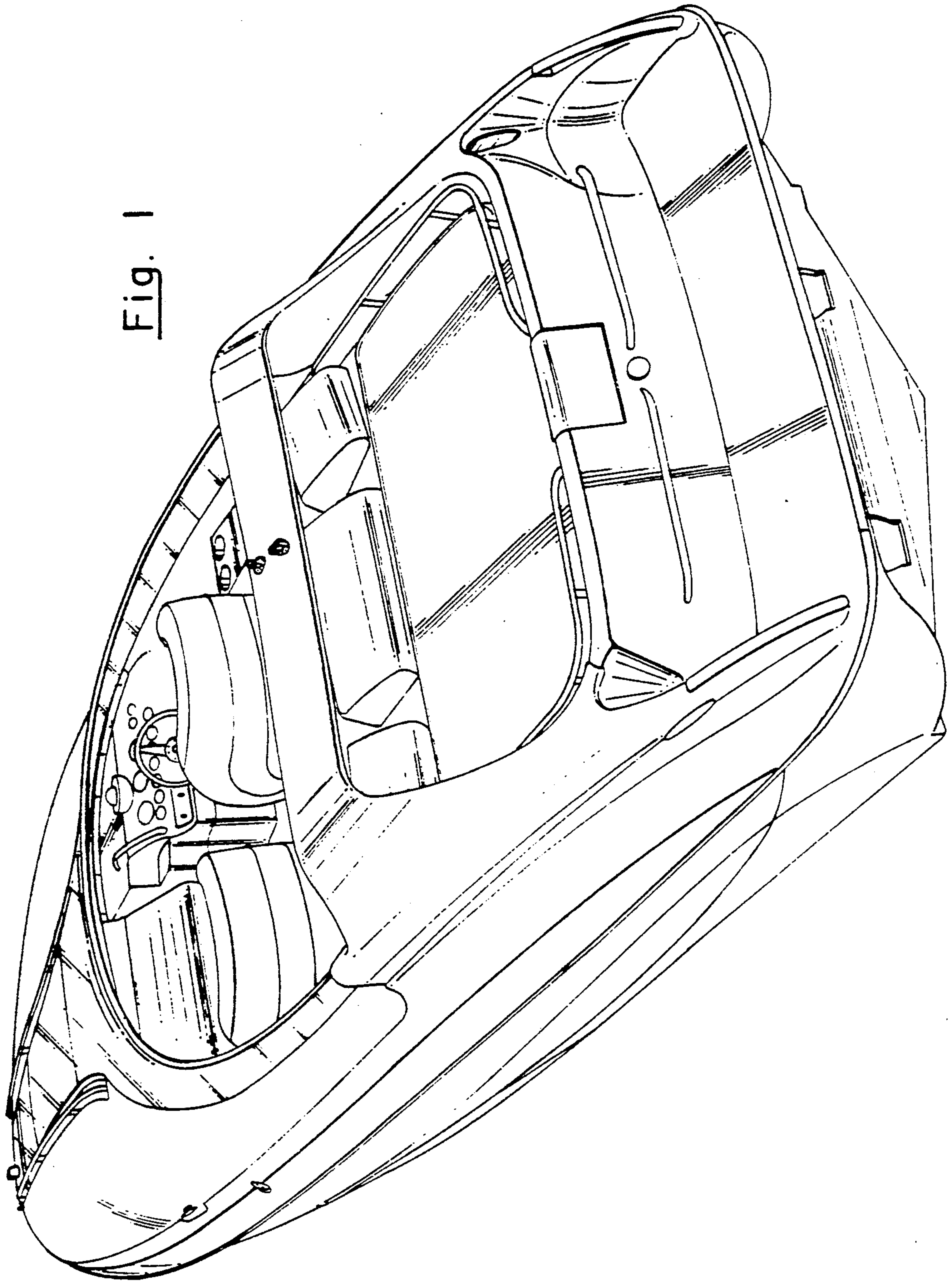

Fig. 1



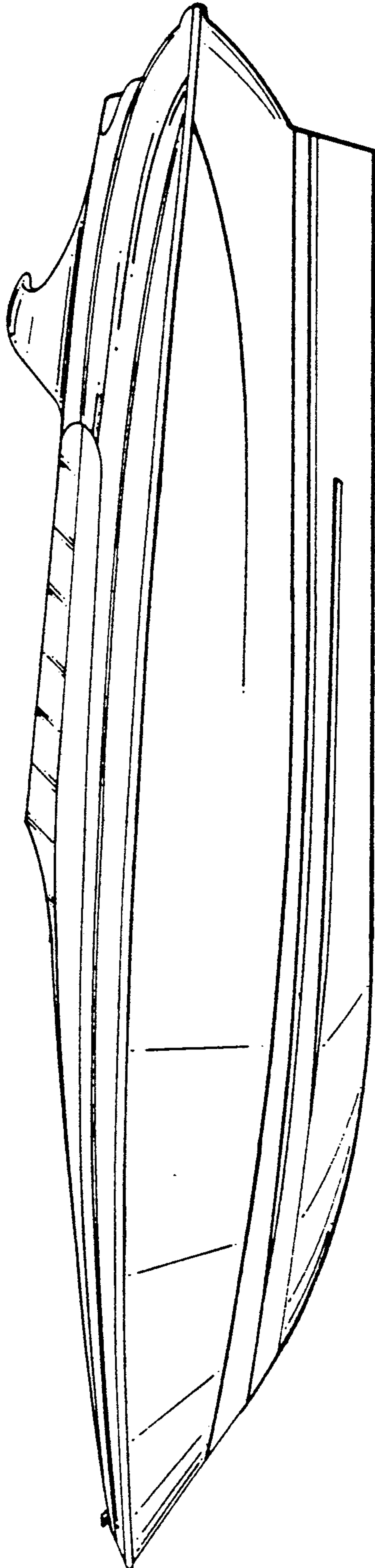

Fig. 2



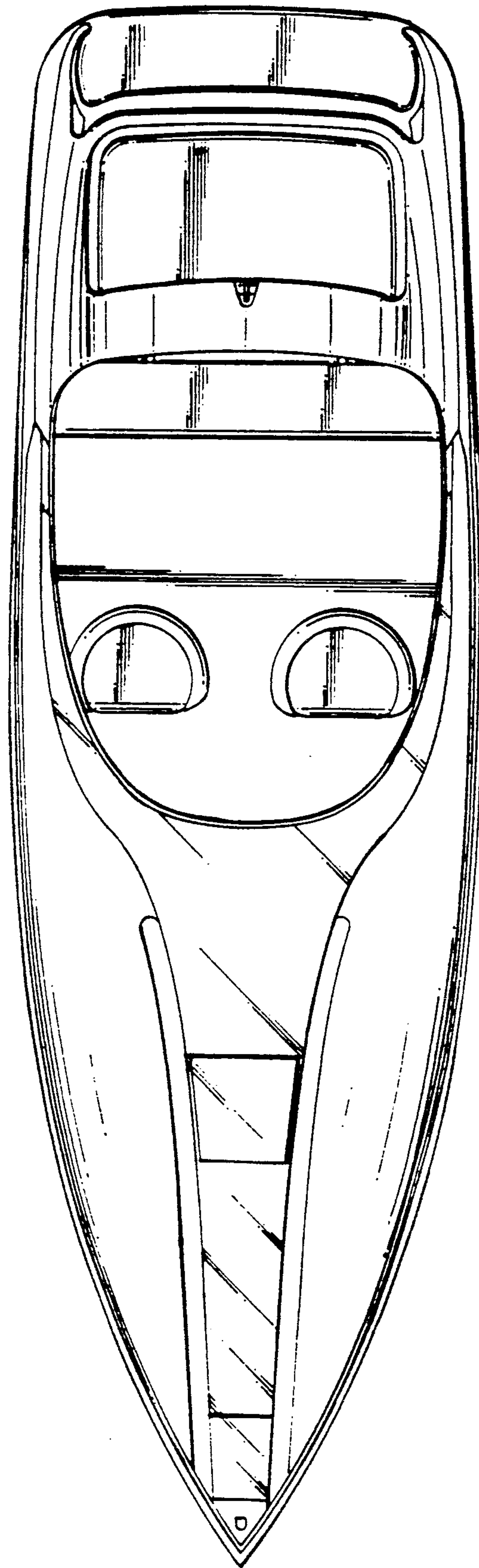

Fig. 3

Fig. 5

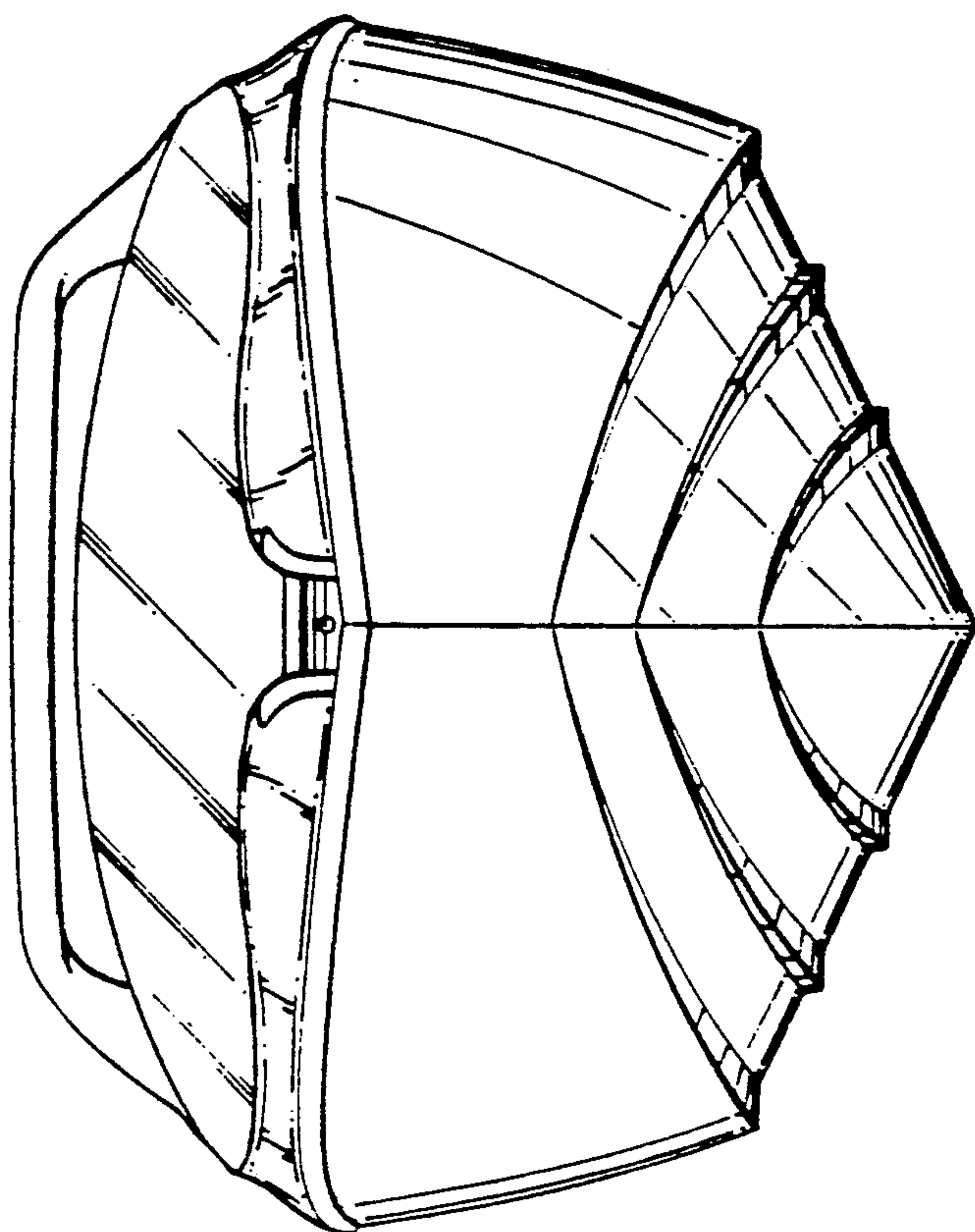
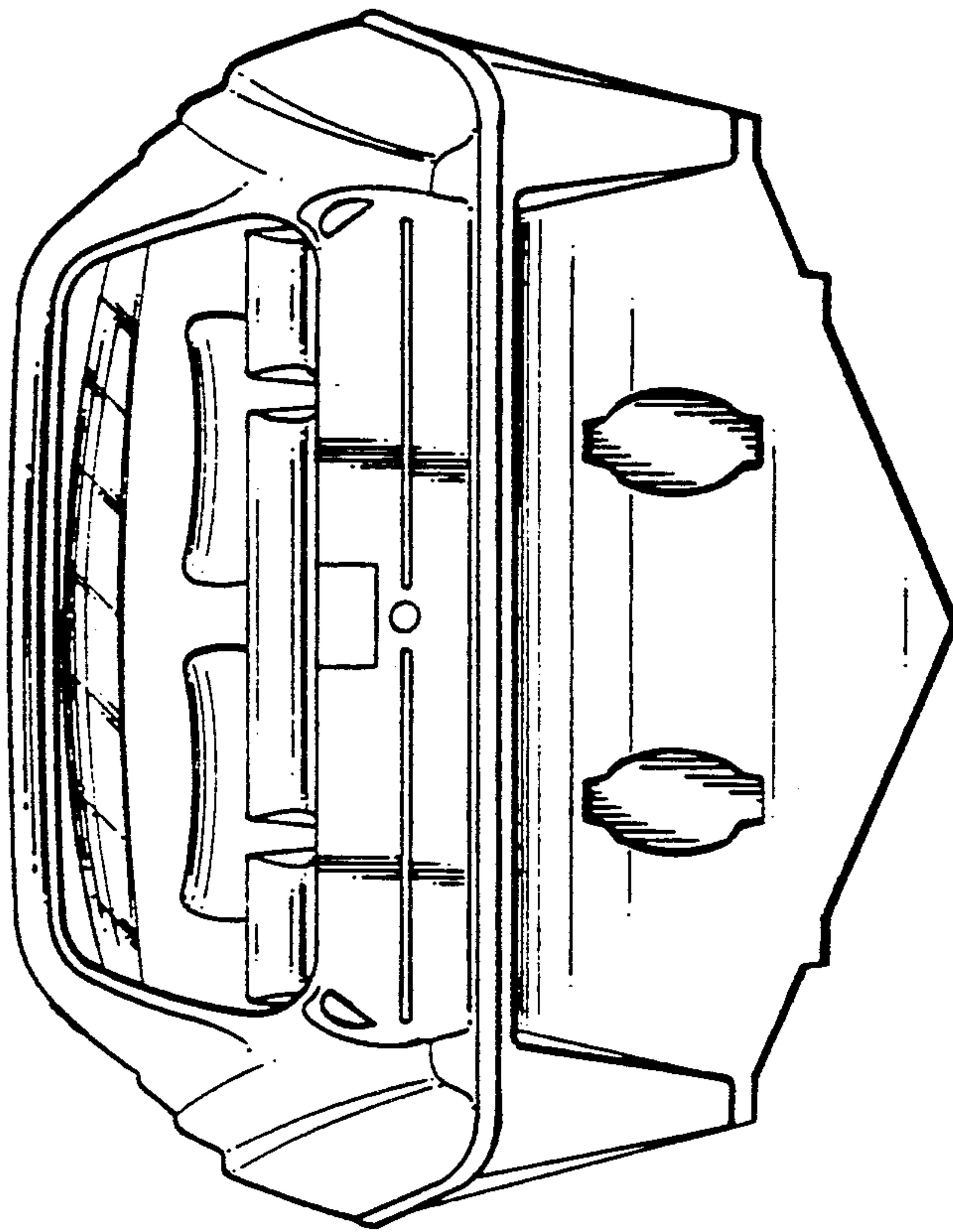

Fig. 4