

[54] **FOLDING TRAY FOR VEHICLES**

[76] **Inventor: Meung-Joung Shu, 7Fl., No. 37, Lane 697, Tun-Hua S. Rd., Taipei, Taiwan**

[\*\*] **Term: 14 Years**

[21] **Appl. No.: 358,046**

[22] **Filed: May 30, 1989**

[52] **U.S. Cl. .... D3/40**

[58] **Field of Search .... D3/40; D12/155, 177; D7/553, 554, 555, 616, 619, 620, 621; 224/273, 275, 276, 279, 42.42, 42.43; 108/45; 248/311.2; 211/88, 126; 296/37.1, 37.5, 37.8, 37.12**

[56] **References Cited**

**U.S. PATENT DOCUMENTS**

D. 292,445	10/1987	Judge	.....	D3/40
1,900,325	3/1933	Bayman et al.	.....	108/45
2,270,557	1/1942	Randall	.....	108/45
2,597,330	5/1952	Huddleston	.....	108/45
2,719,066	9/1955	Budzinski	.....	108/45
2,825,611	3/1958	Aynsworth	.....	108/45

**FOREIGN PATENT DOCUMENTS**

885350 11/1971 Canada ..... 224/276

*Primary Examiner*—James M. Gandy  
*Attorney, Agent, or Firm*—Varndell Legal Group

[57] **CLAIM**

The ornamental design for a folding tray for vehicles, as shown and described.

**DESCRIPTION**

FIG. 1 is a perspective view taken from above and one side of a folding tray for vehicles showing my new design;

FIG. 2 is a top plan view thereof;

FIG. 3 is a front elevation view thereof;

FIG. 4 is a rear elevation view thereof;

FIG. 5 is a bottom plan view thereof;

FIG. 6 is a side elevation view thereof;

FIG. 7 is a side elevation view thereof in folded condition;

FIG. 8 is an enlarged fragmentary perspective view of one of the hinge connections thereof in exploded condition; and

FIG. 9 is a side elevation view thereof in an alternate position of use.

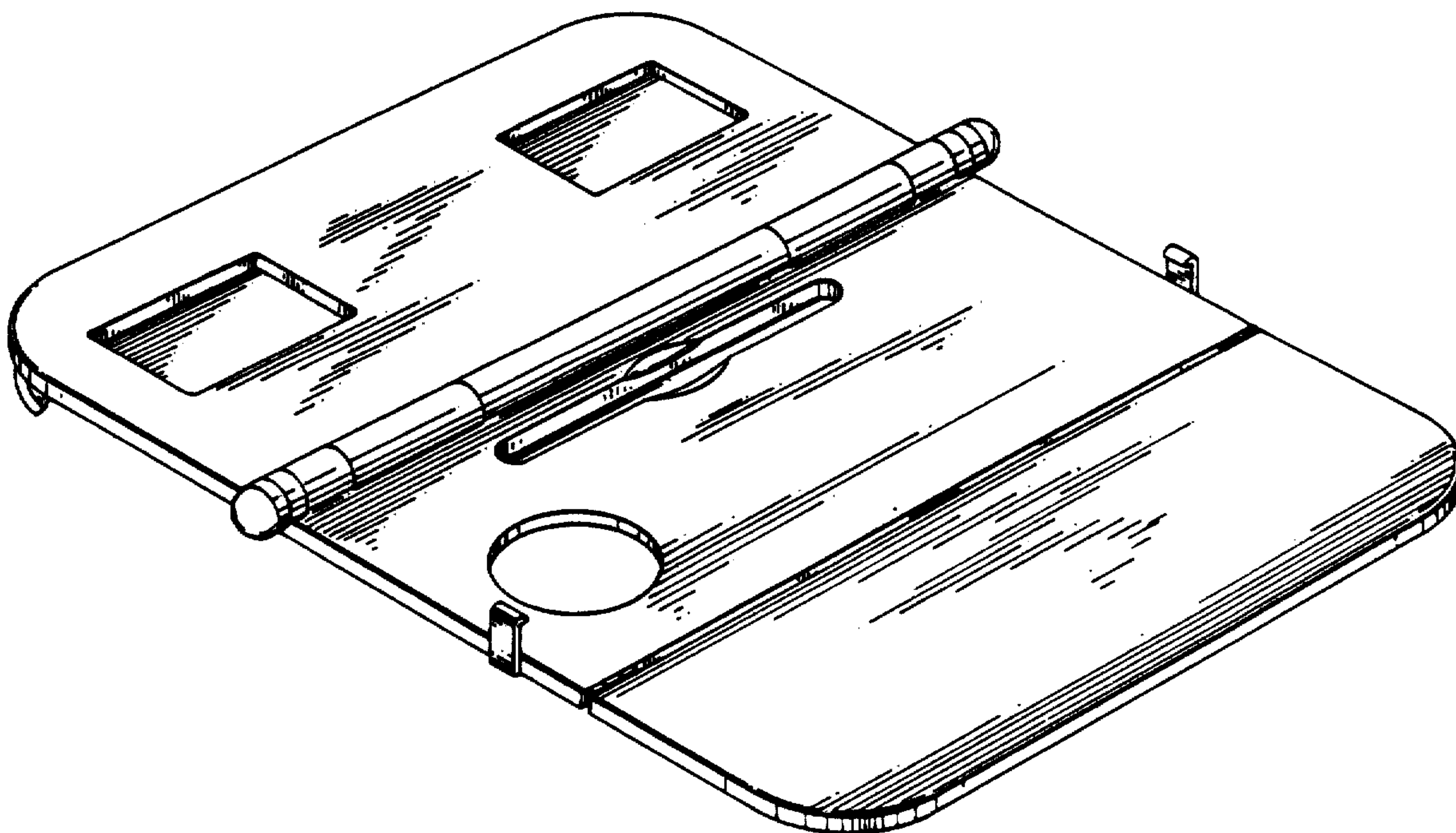

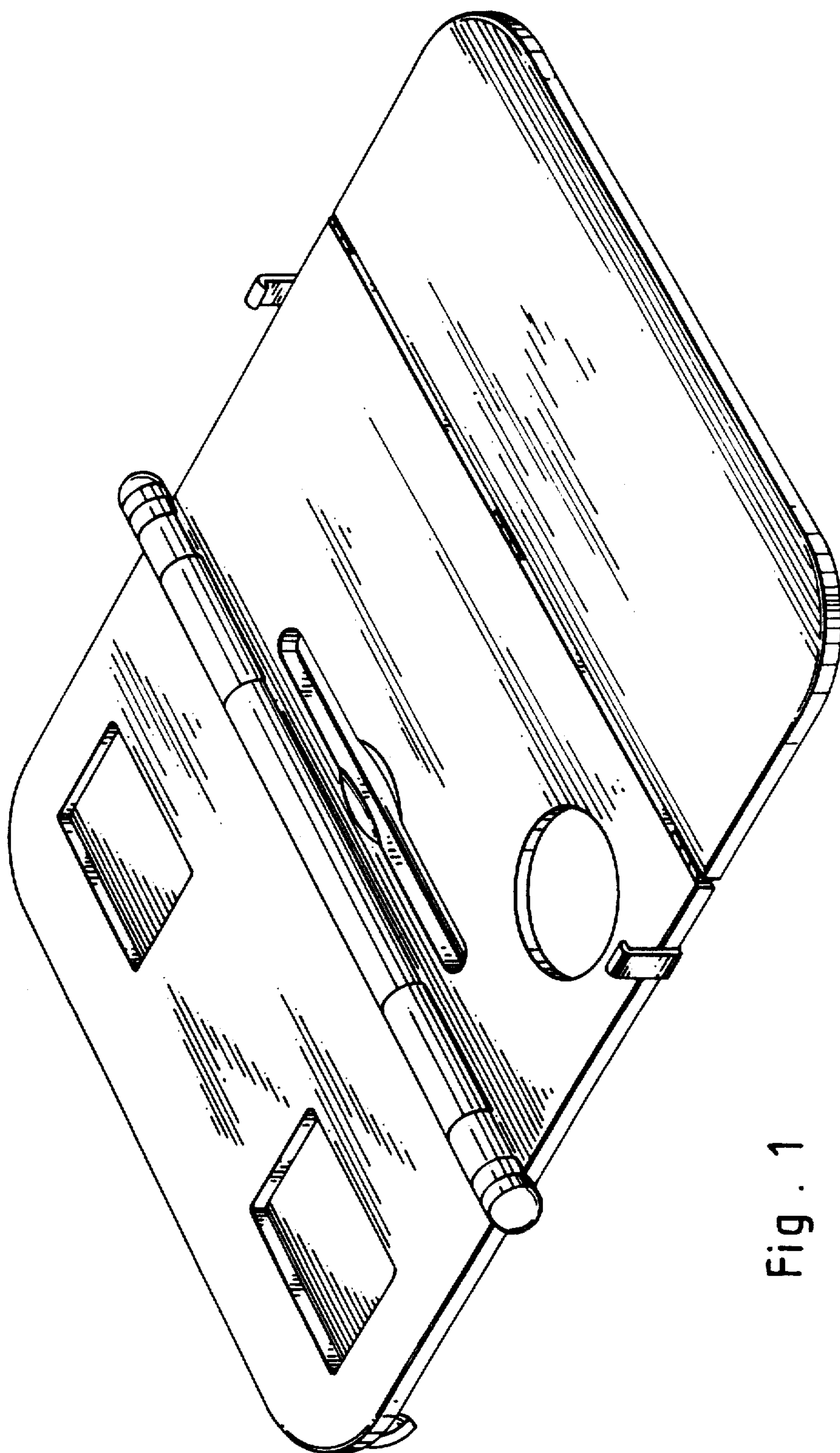

Fig. 1

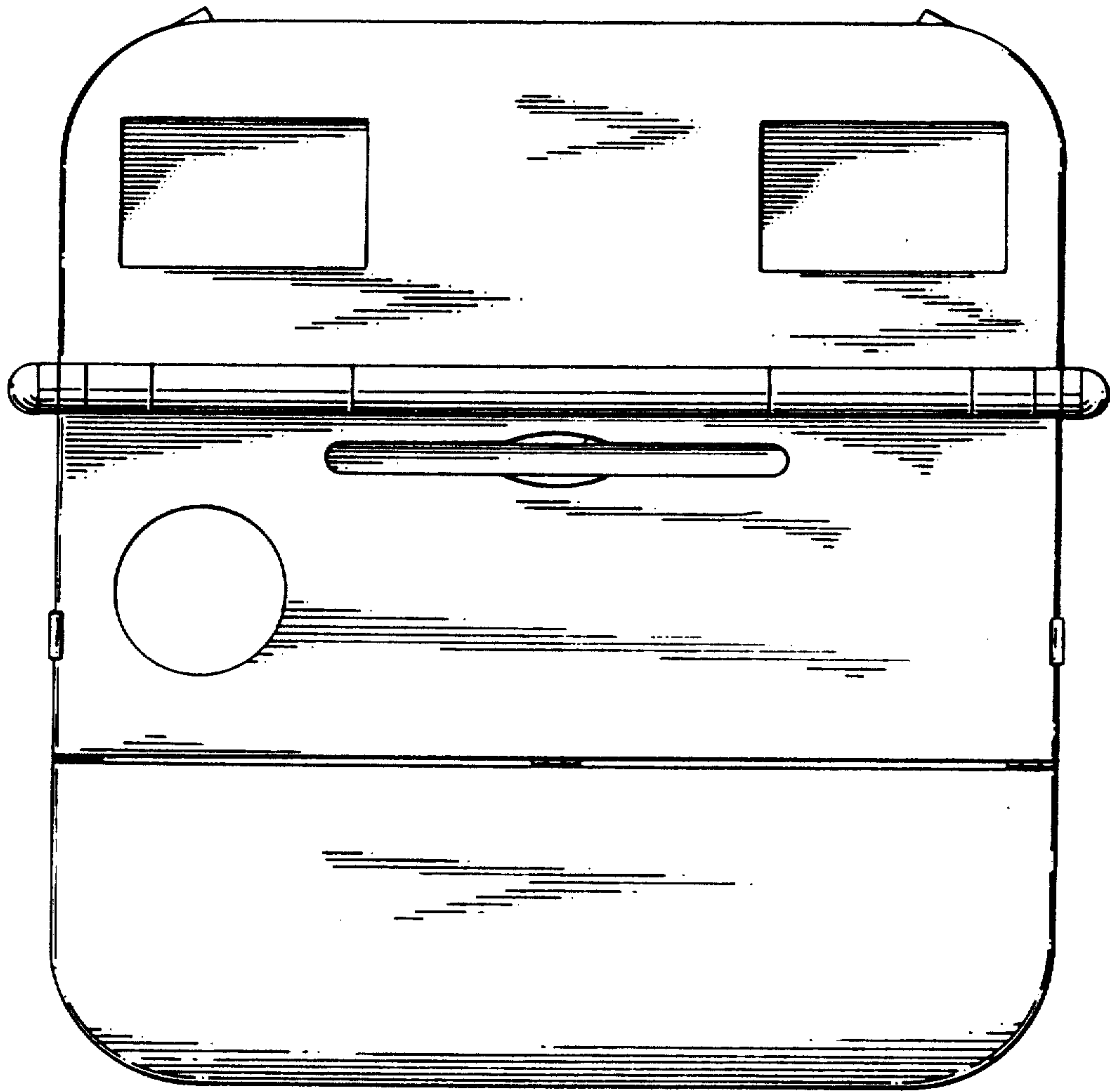

Fig. 2

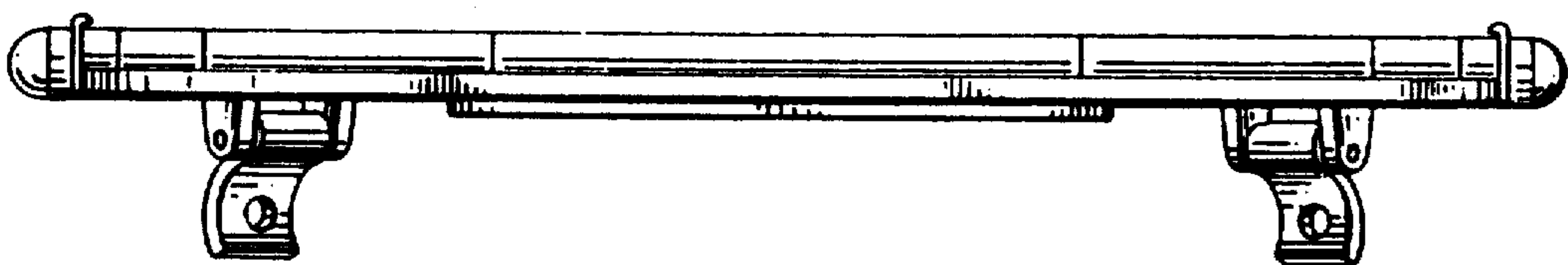

Fig. 3



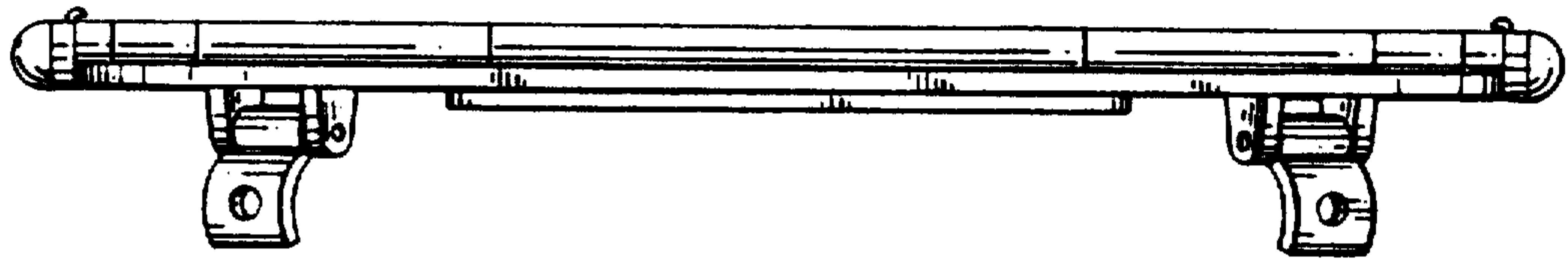

Fig. 4

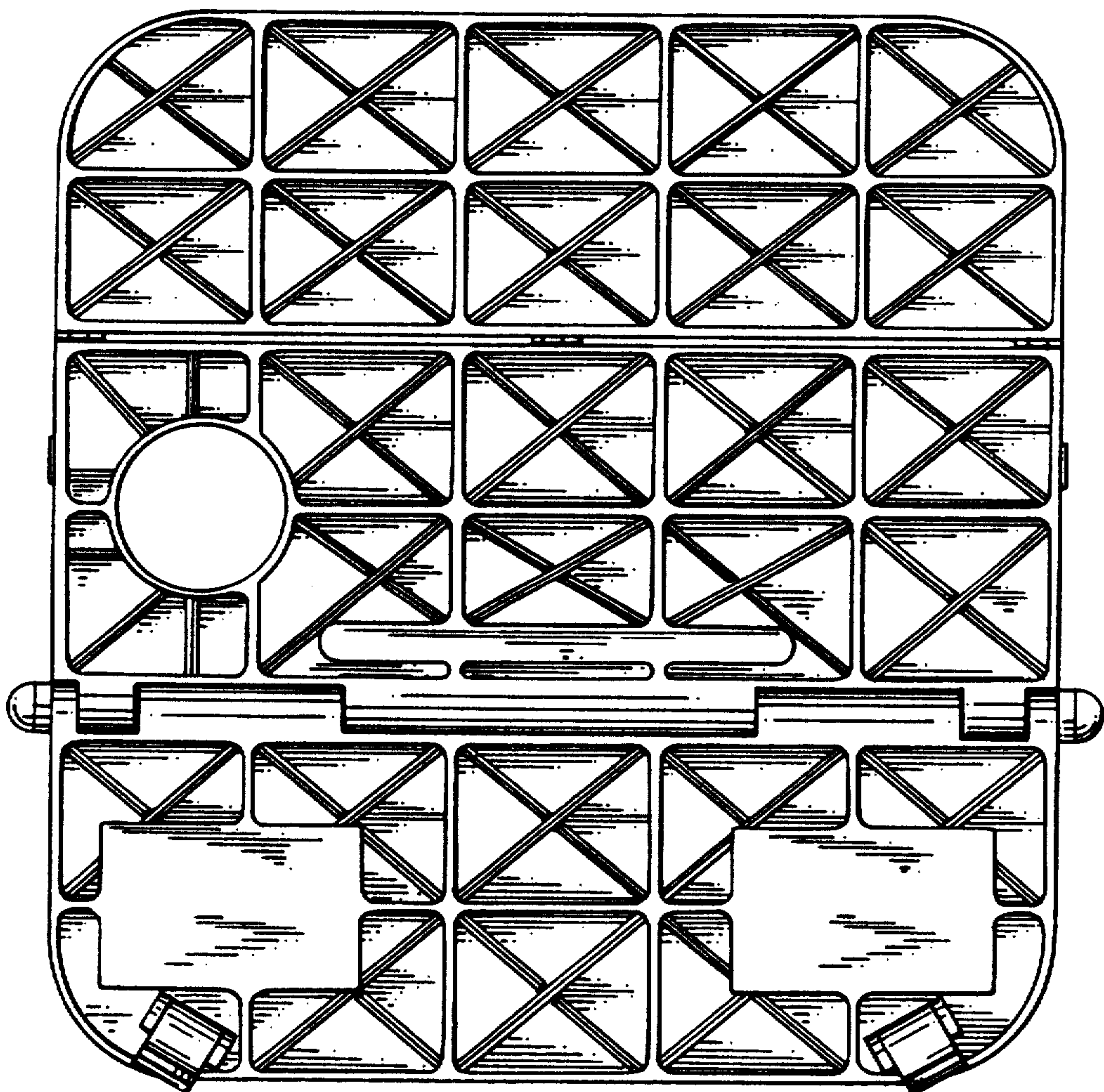

Fig. 5

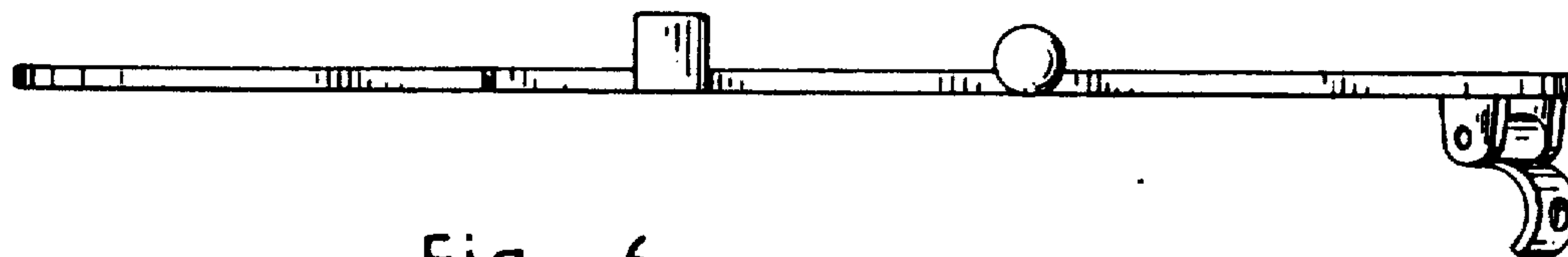

Fig. 6

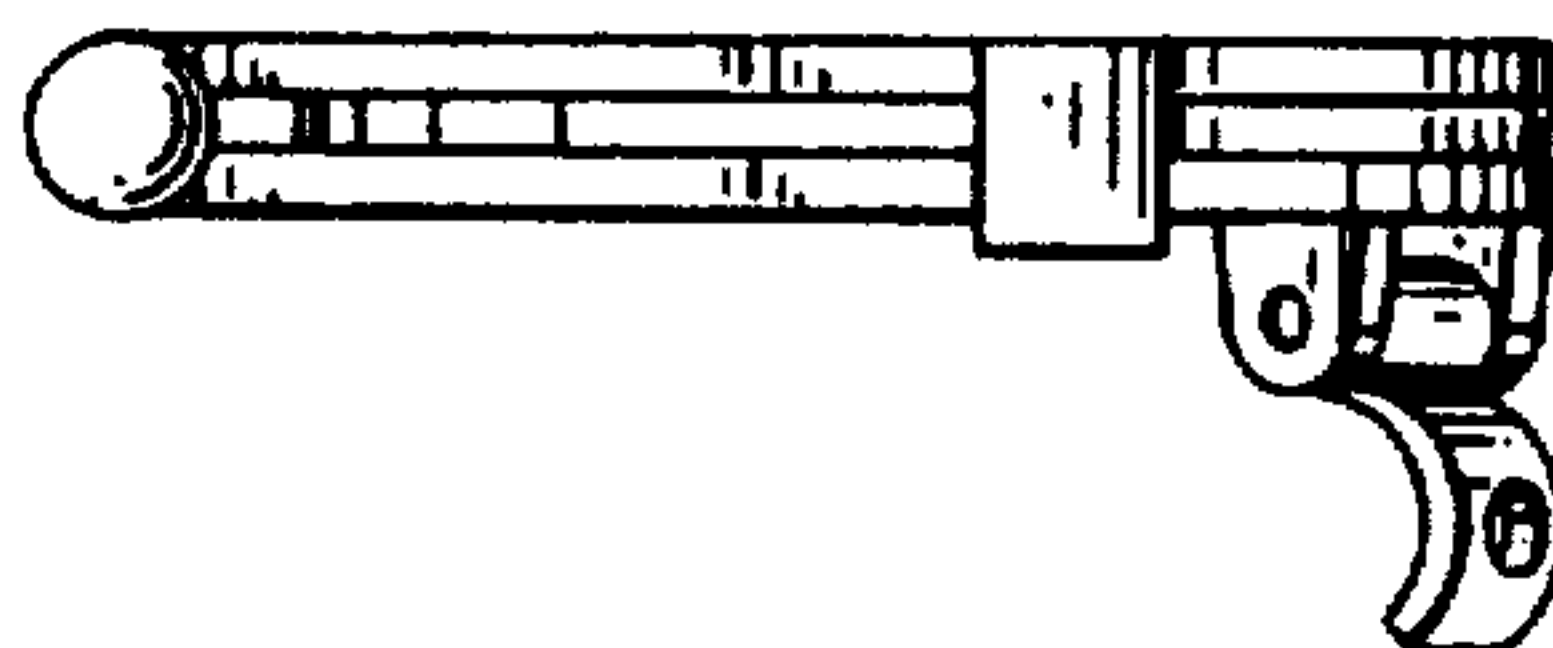

Fig. 7

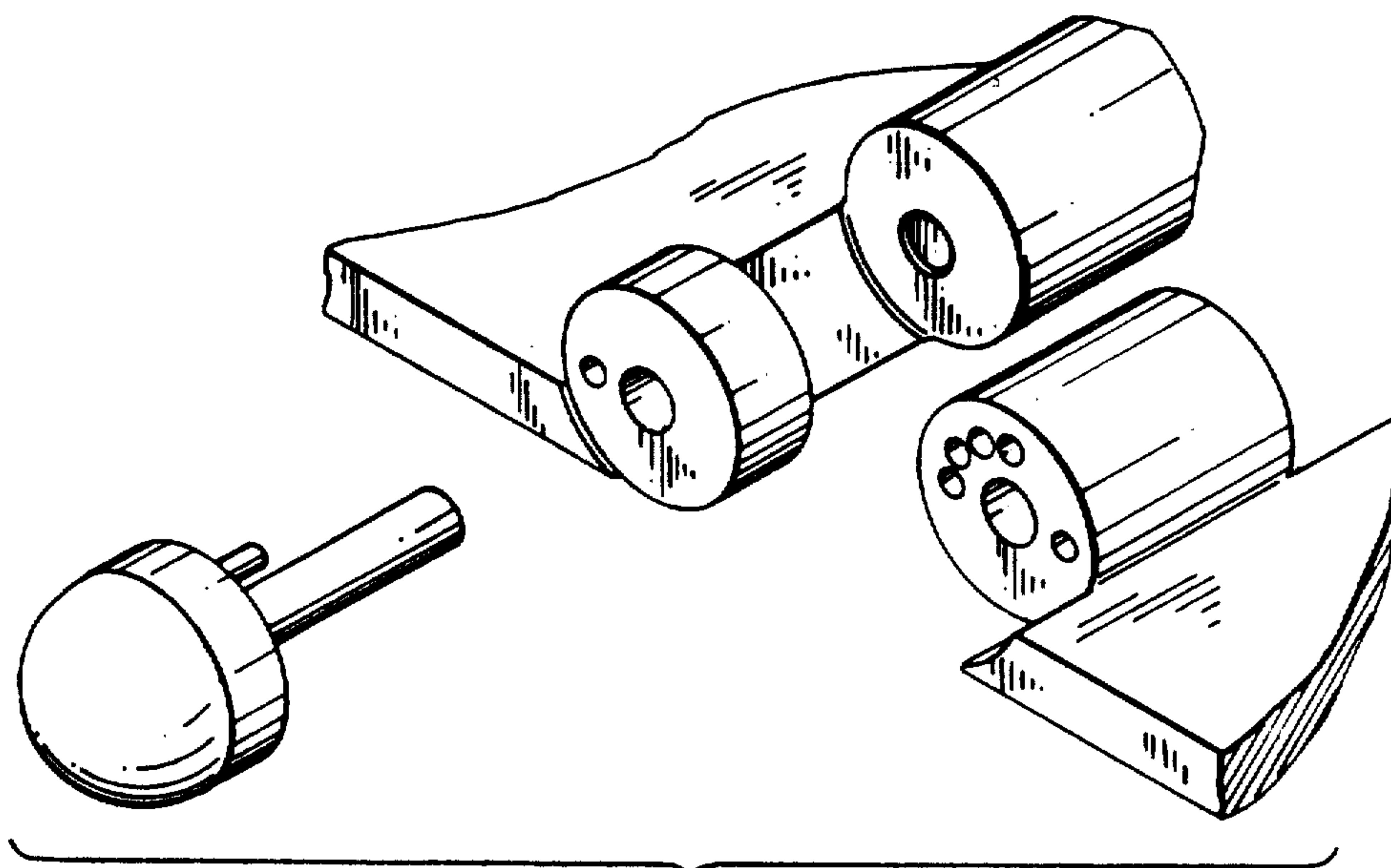

Fig. 8

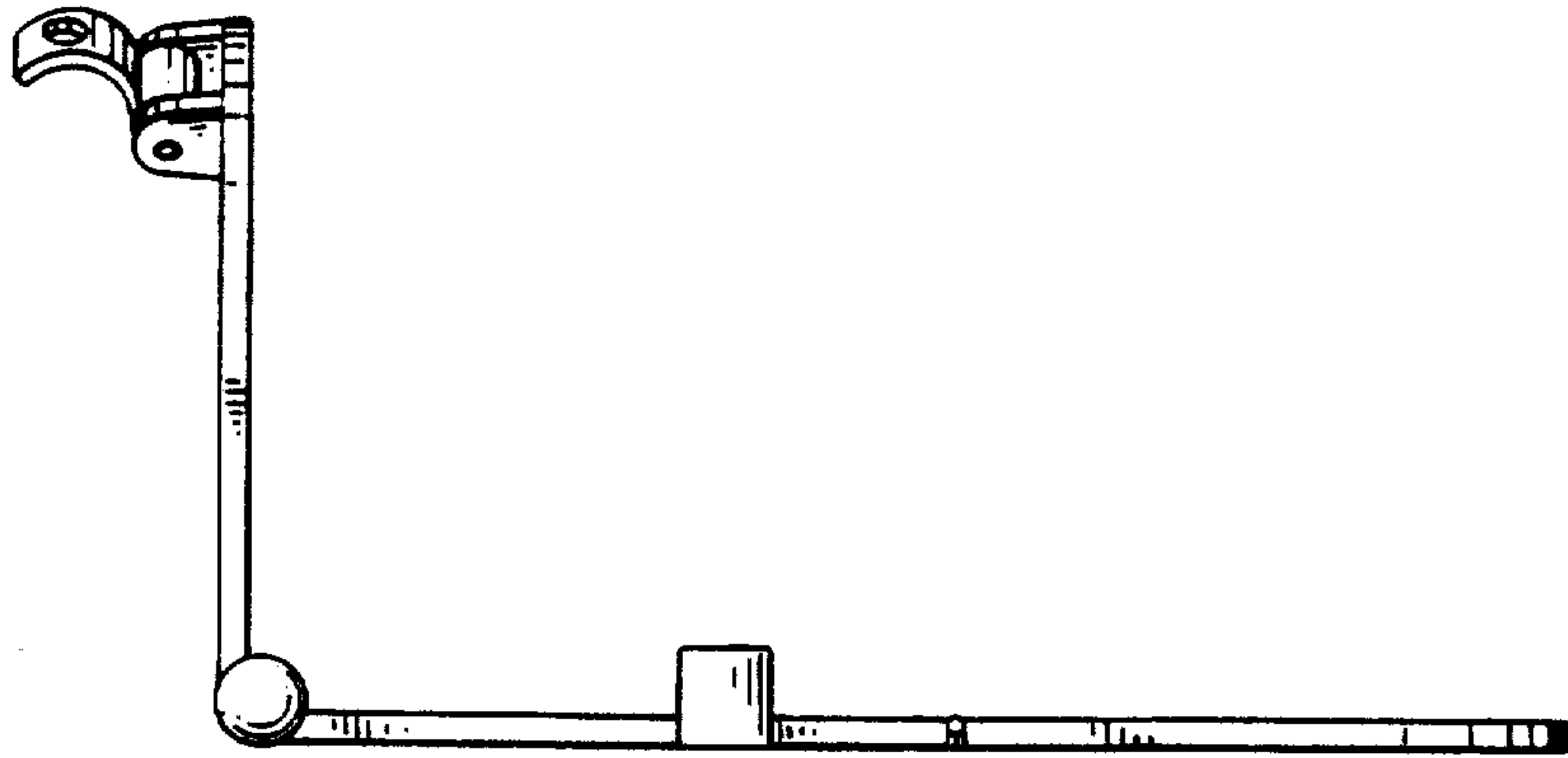

Fig . 9