

[54] TOY CAR

[75] Inventor: Shigeki Araki, Shizuoka, Japan

[73] Assignee: Kabushiki Kaisha Tamiya Mokei, Shizuoka, Japan

[**] Term: 14 Years

[21] Appl. No.: 431,852

[22] Filed: Nov. 6, 1989

[30] Foreign Application Priority Data

Sep. 12, 1989 [JP] Japan 1-33159

[52] U.S. Cl. D21/137

[58] Field of Search D21/136, 137; D12/86, D12/88; 446/444, 446, 454, 455, 456, 470

[56] References Cited

U.S. PATENT DOCUMENTS

D. 227,385	6/1973	Dragster	D21/137
D. 253,605	12/1979	Herd	D21/137
D. 260,913	9/1981	Chapman	D12/88
D. 261,672	11/1981	Phillippe	D12/88
D. 266,779	11/1982	Appel et al.	D21/137
D. 268,940	5/1983	Head	D12/88

OTHER PUBLICATIONS

Hong Kong Toys '88, p. 242, #889.
Hong Kong Toys '88, p. 86, "Turbo Eagle".
Monogram Catalog 1987, p. 43, Toy Fair '87.
Hong Kong Toys '88, p. 242, #3300.

Primary Examiner—Charles A. Rademaker
Assistant Examiner—R. Barkai
Attorney, Agent, or Firm—Finnegan, Henderson, Farabow, Garrett & Dunner

[57] CLAIM

The ornamental design for a toy car, as shown and described.

DESCRIPTION

FIG. 1 is a perspective view of a toy car showing my new design;
FIG. 2 is a front elevational view thereof;
FIG. 3 is a rear elevational view thereof;
FIG. 4 is a top plan view thereof;
FIG. 5 is a bottom plan view thereof;
FIG. 6 is a right side elevational view thereof; and
FIG. 7 is a left side elevational view thereof.

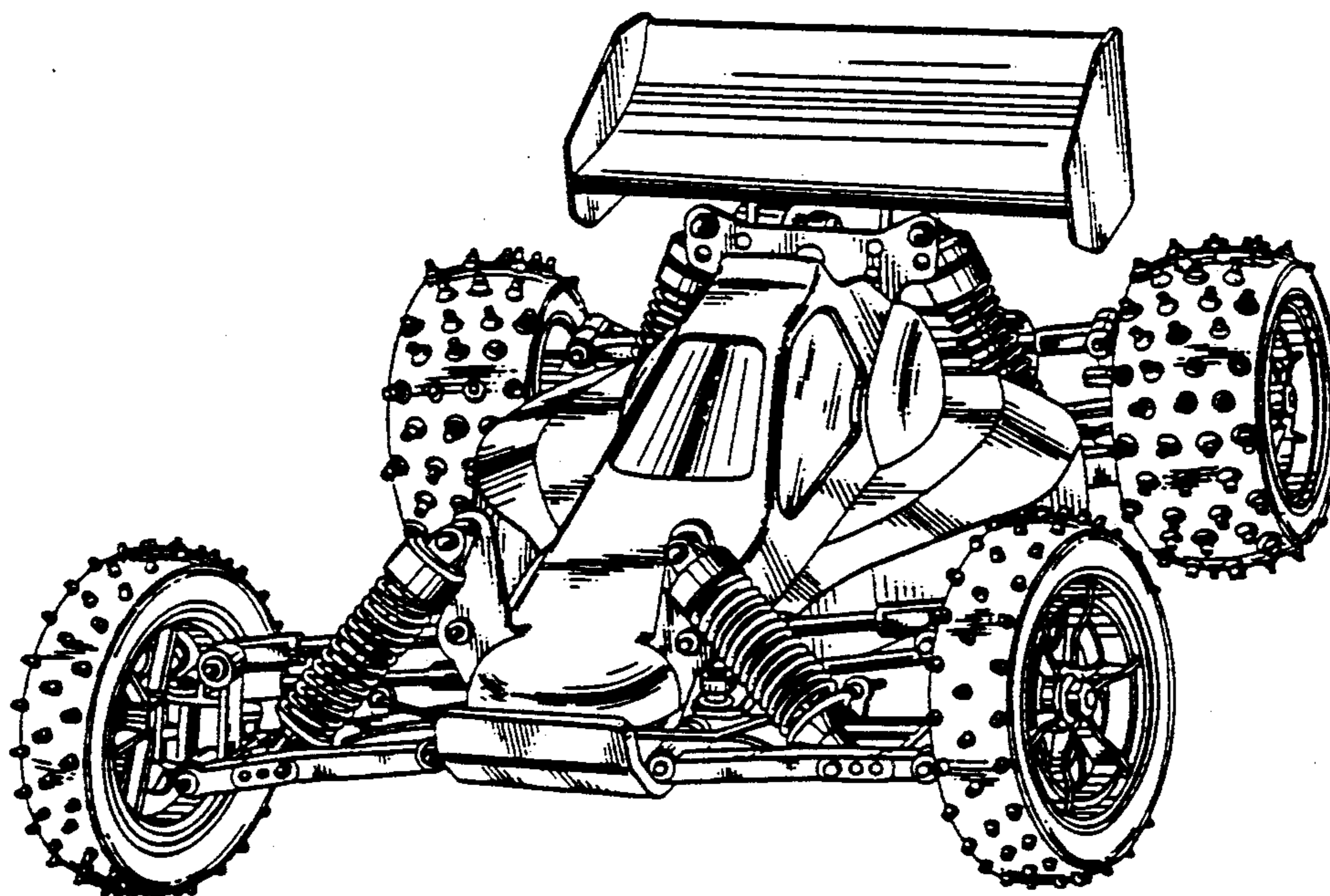
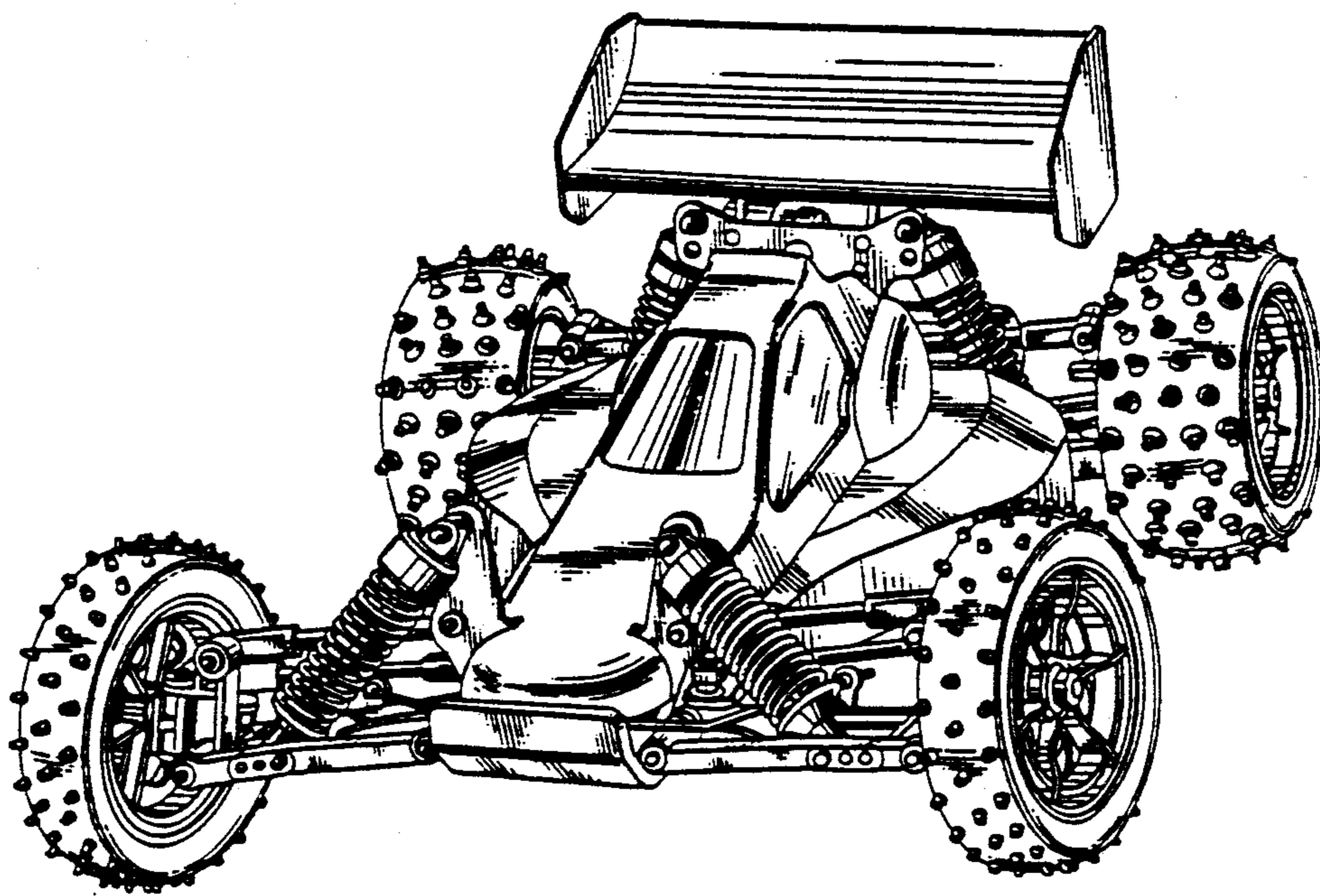

FIG. 1



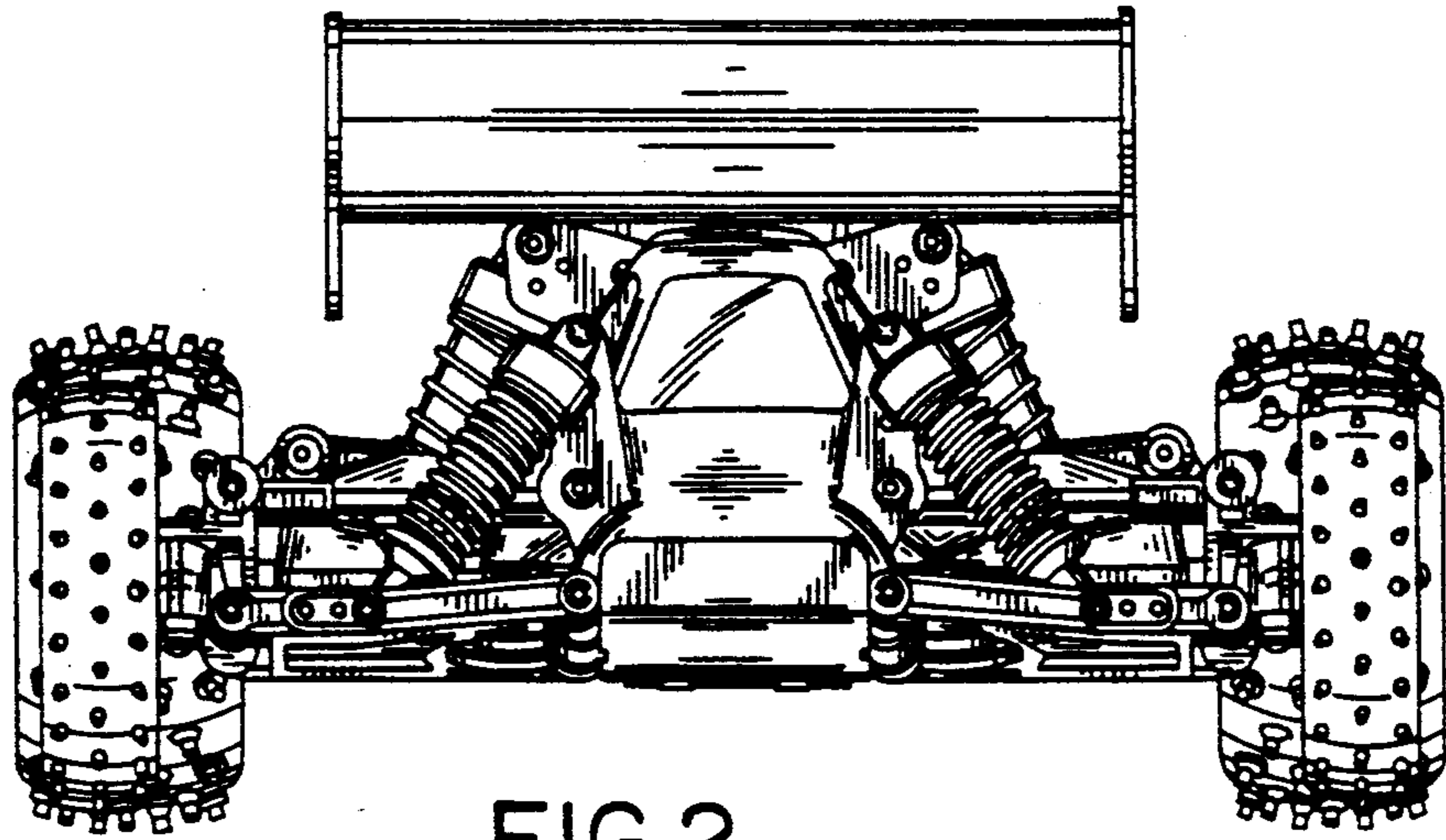

FIG. 2

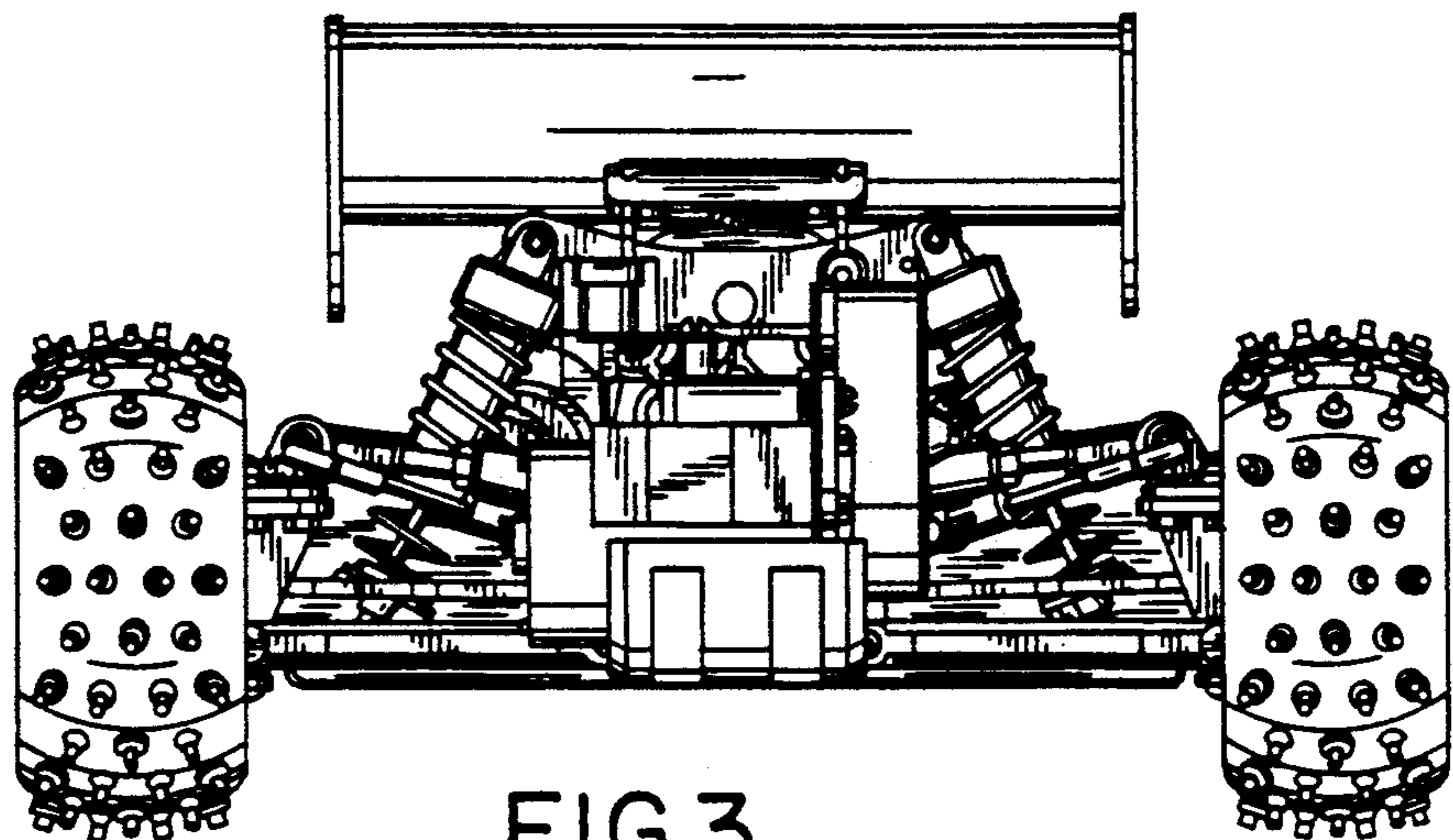

FIG. 3

FIG. 4

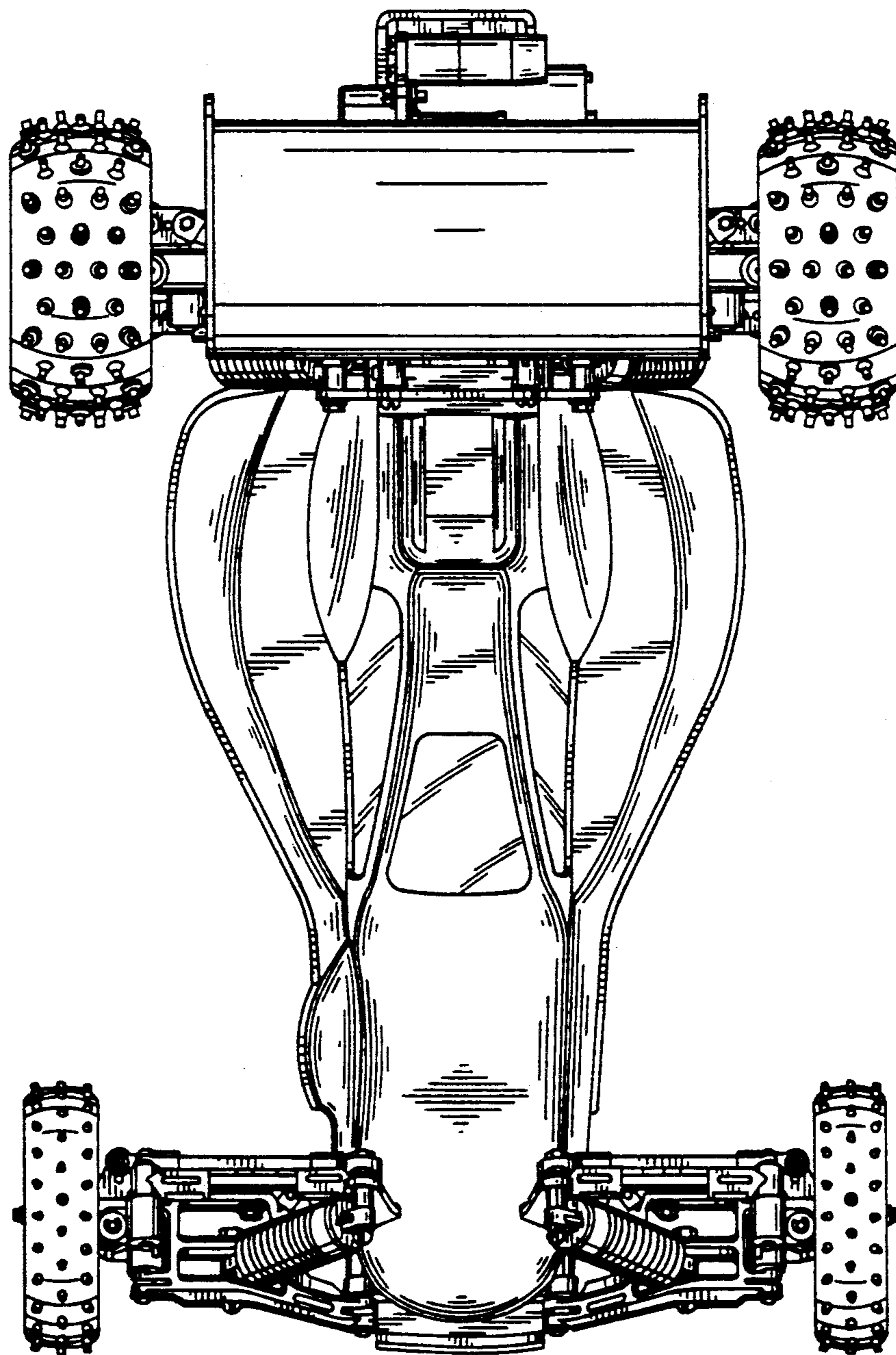

FIG.5

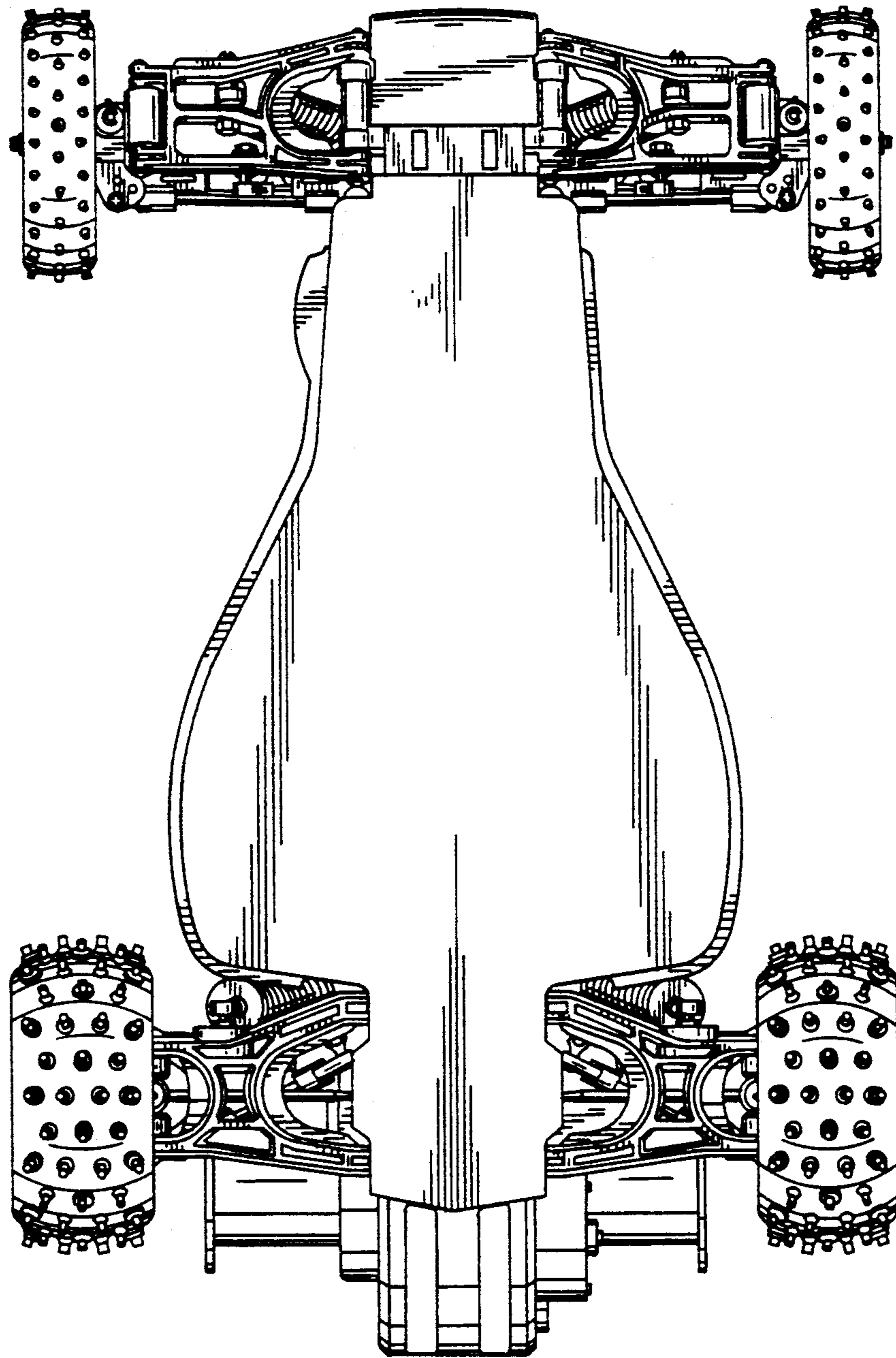

FIG.6

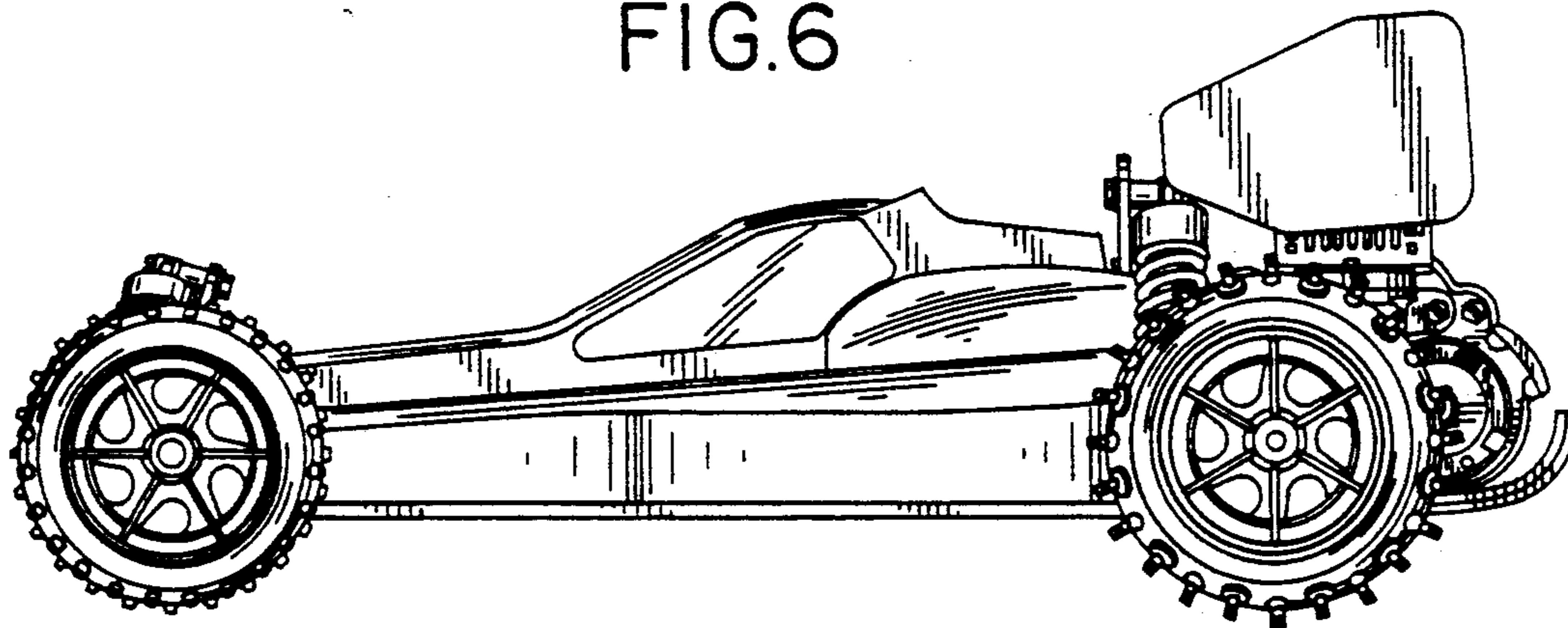

FIG.7

