

[54] **VEHICLE CONTROL SIMULATOR**

[75] **Inventor:** Wynford P. Holloway, Cardiff,  
United Kingdom

[73] **Assignee:** Creative Devices Research Ltd.,  
Gwent, England

[\*\*] **Term:** 14 Years

[21] **Appl. No.:** 255,521

[22] **Filed:** Oct. 5, 1988

[30] **Foreign Application Priority Data**

Apr. 5, 1988 [GB] United Kingdom ..... 1049705

May 27, 1988 [GB] United Kingdom ..... 1051036

May 27, 1988 [GB] United Kingdom ..... 1051037

[52] **U.S. Cl.** ..... **D19/63**

[58] **Field of Search** ..... D19/59, 60, 61, 62,  
D19/63, 64; D21/48, 71, 77, 78, 82, 136, 141,  
13; 434/45, 62, 63, 64, 65, 308, 309, 310, 315

[56] **References Cited**

**U.S. PATENT DOCUMENTS**

D. 297,028 8/1988 McCann ..... D19/63 X

*Primary Examiner*—Wallace R. Burke

*Assistant Examiner*—P. Schmidt

*Attorney, Agent, or Firm*—Edwin D. Schindler

[57] **CLAIM**

The ornamental design for a vehicle control simulator,  
as shown and described.

**DESCRIPTION**

FIG. 1 is a front perspective view of a vehicle control simulator showing my new design;

FIG. 2 is a rear perspective view thereof;

FIG. 3 is a right side elevational view thereof;

FIG. 4 is a bottom plan view thereof;

FIG. 5 is a left side elevational view thereof;

FIG. 6 is a front perspective view of a second embodiment of FIG. 1 showing my new design;

FIG. 7 is a rear perspective view thereof;

FIG. 8 is a left side elevational view thereof;

FIG. 9 is a bottom plan view thereof;

FIG. 10 is a right side elevational view thereof;

FIG. 11 is a front perspective view of a third embodiment of FIG. 1 showing my new design;

FIG. 12 is a rear perspective view thereof;

FIG. 13 is a left side elevational view thereof;

FIG. 14 is a bottom plan view thereof; and

FIG. 15 is a right side elevational view thereof.

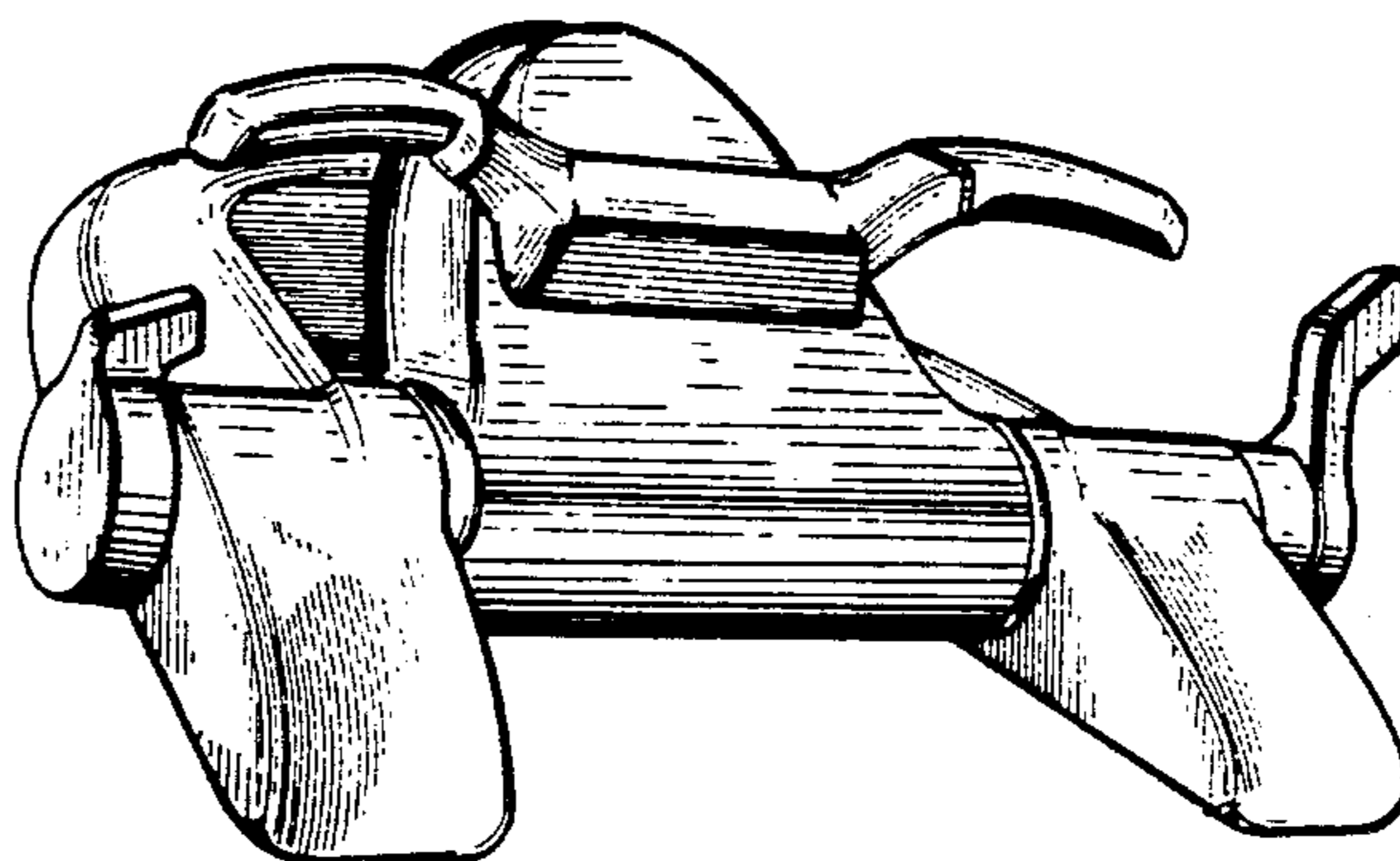
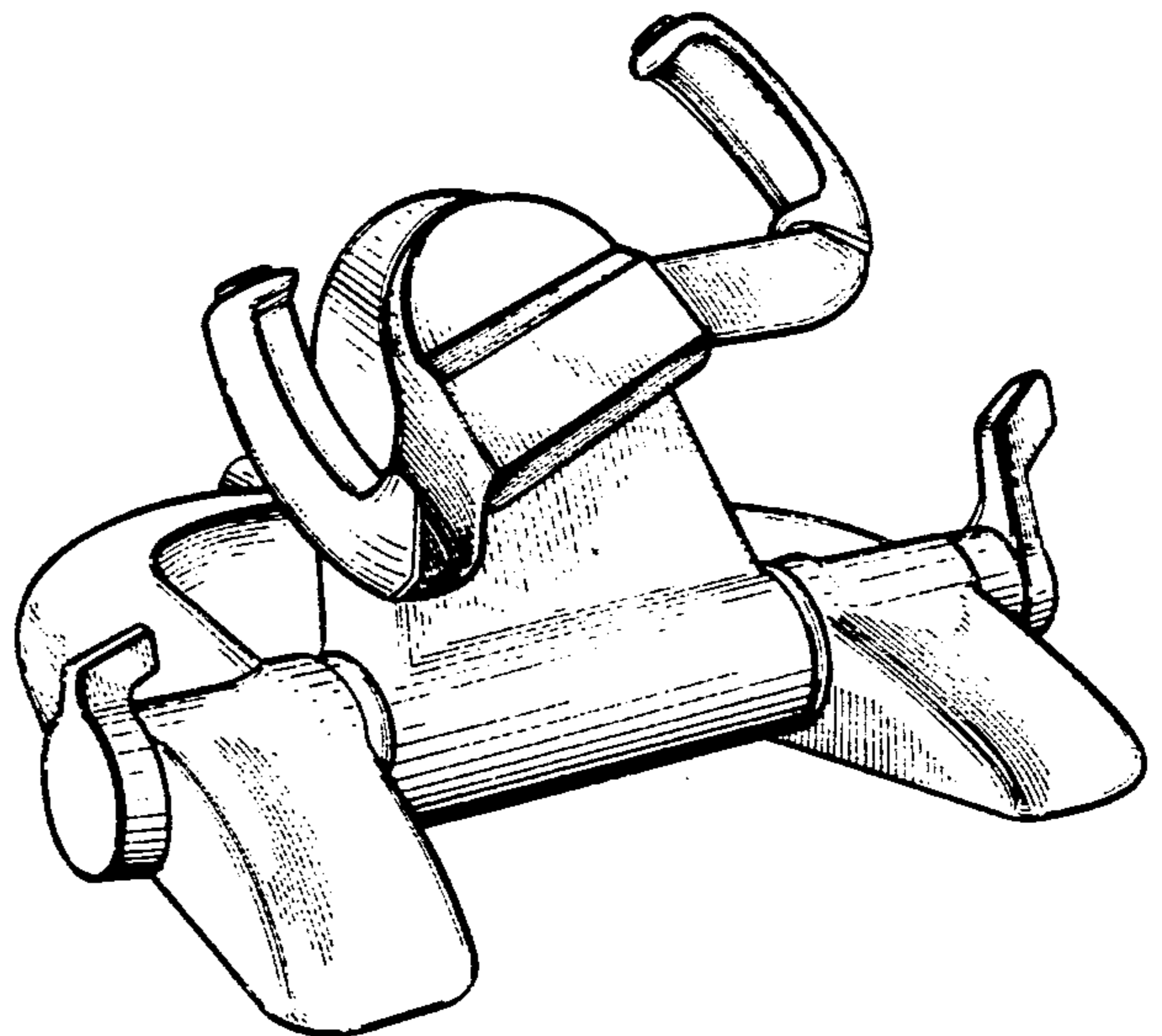
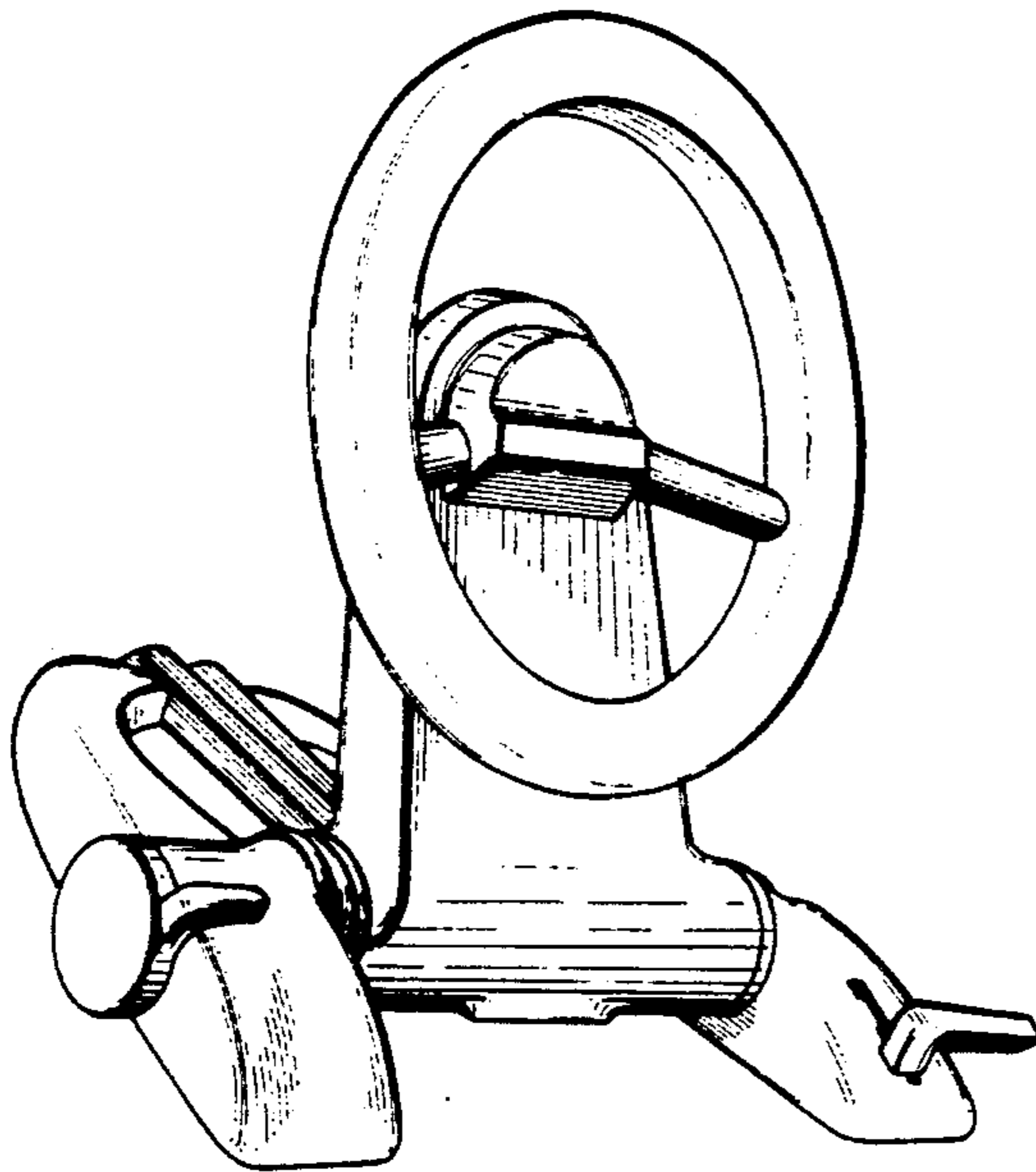

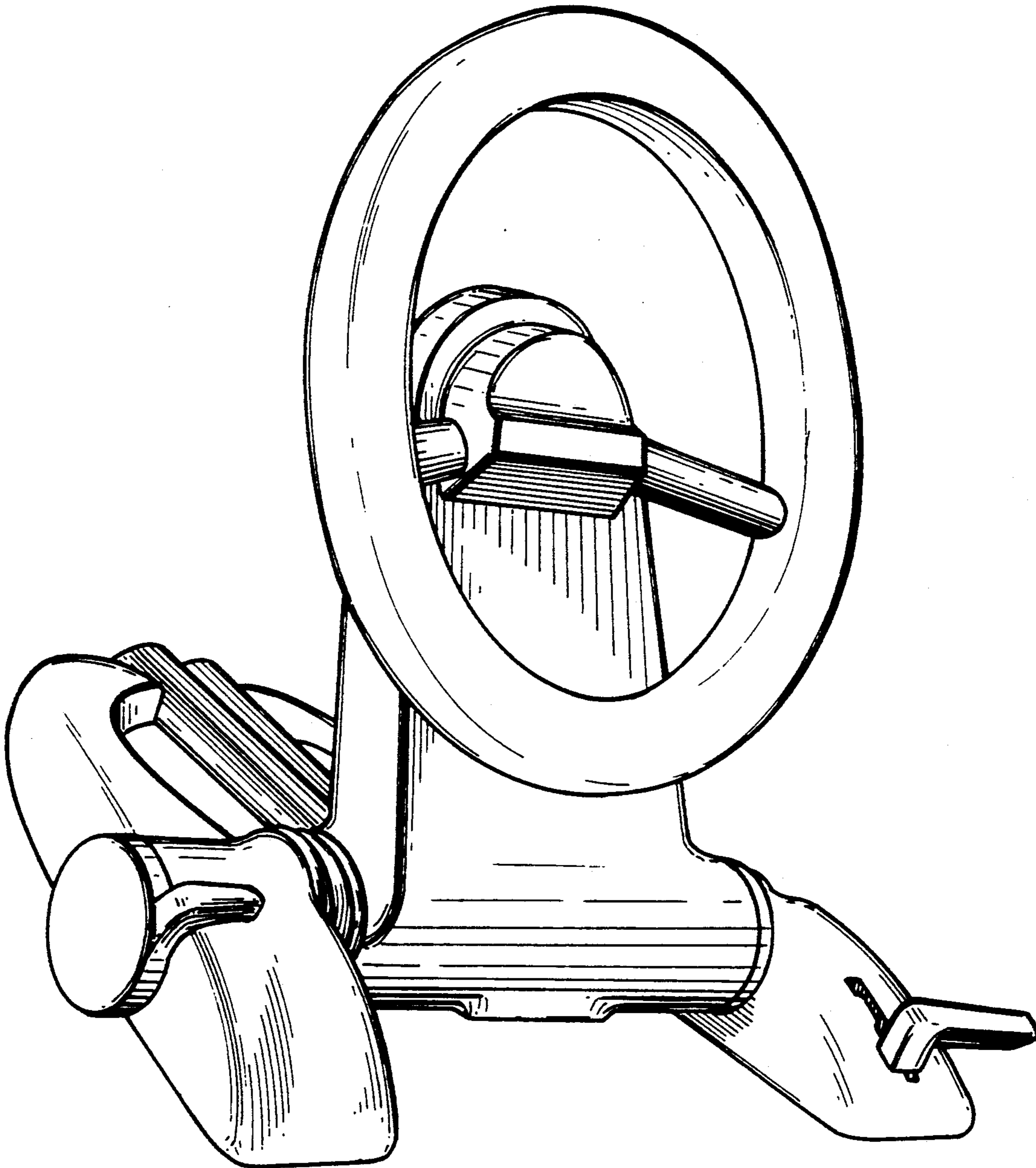

Fig. 1

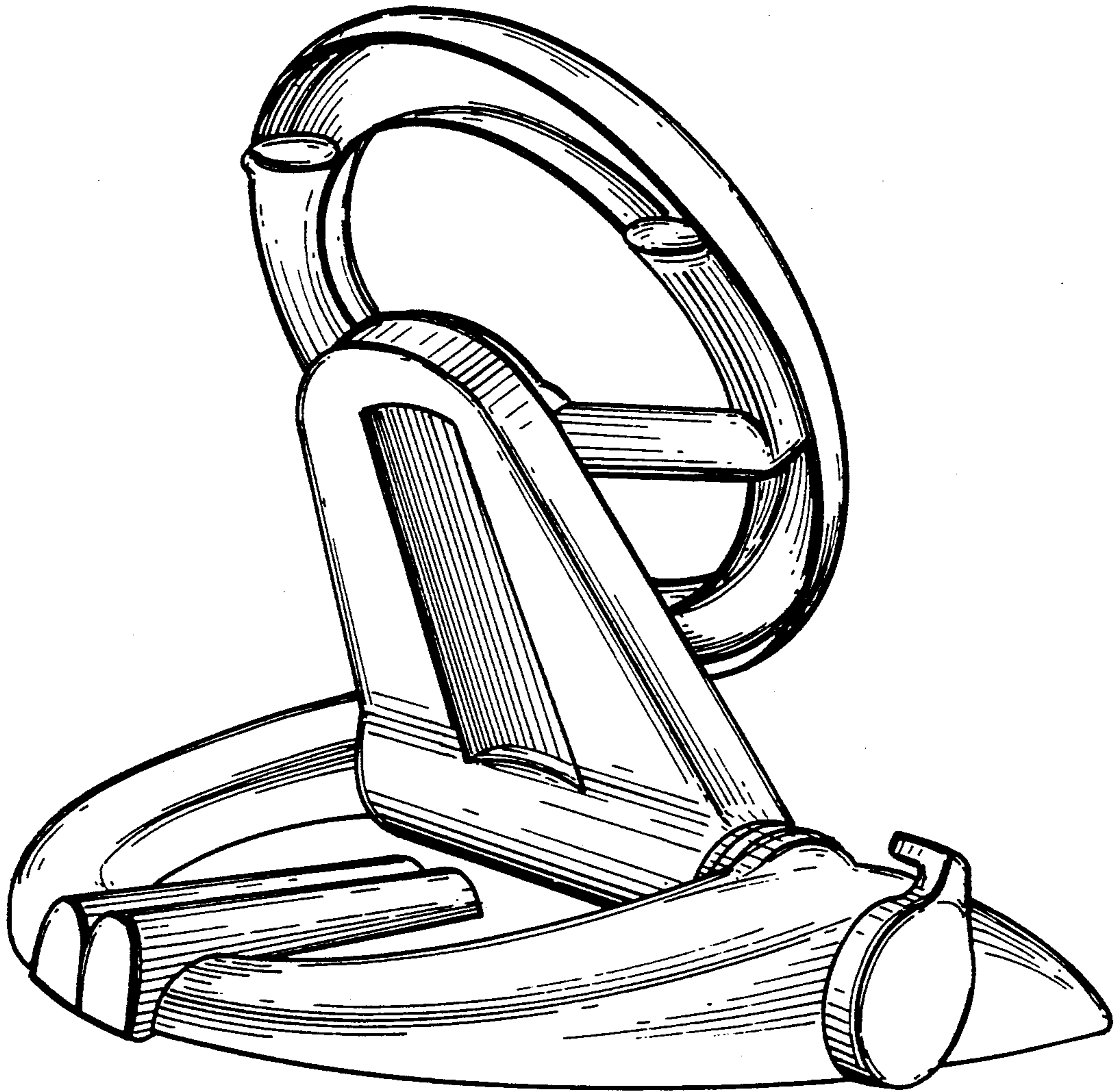

Fig. 2

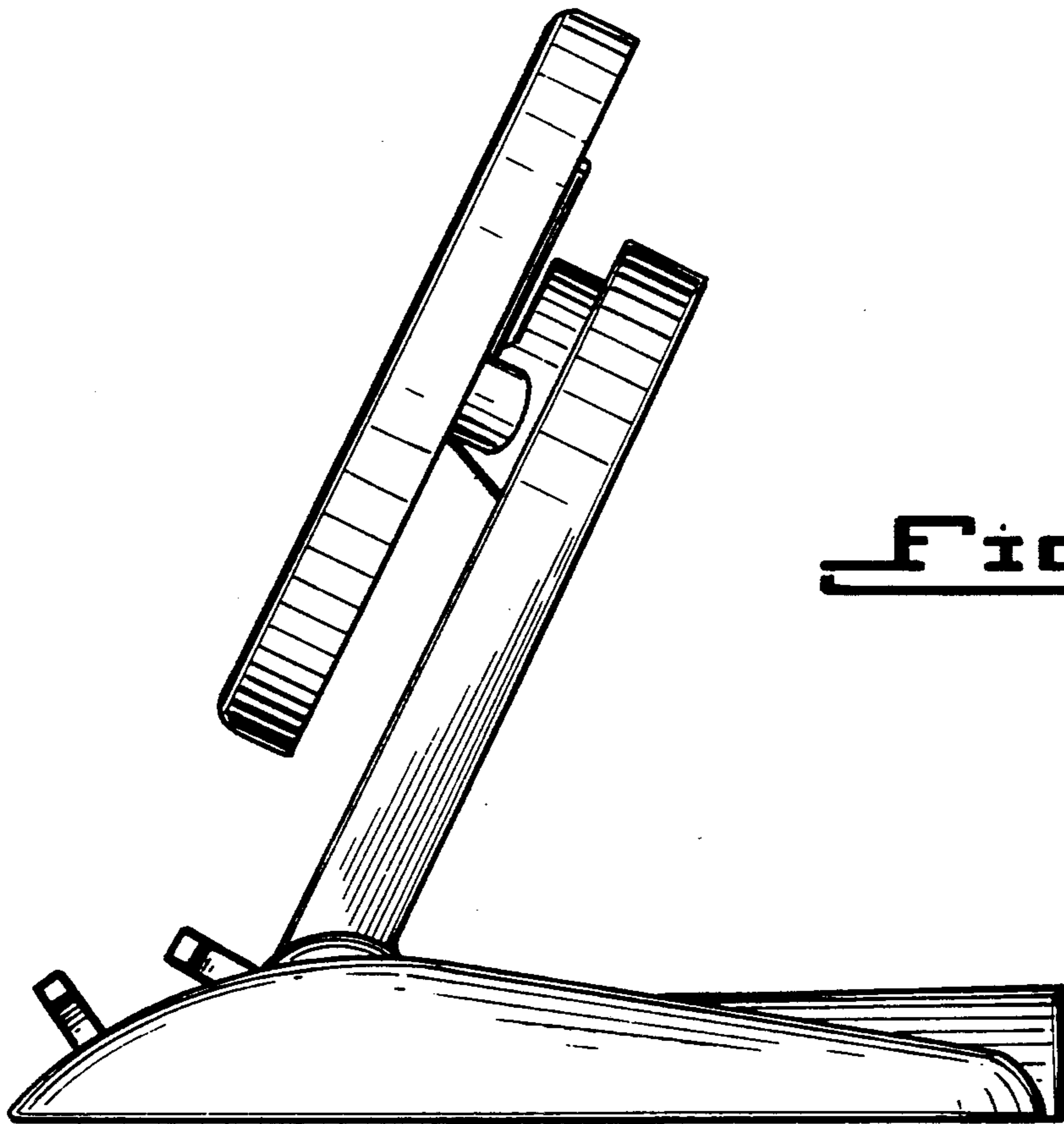

Fig. 3

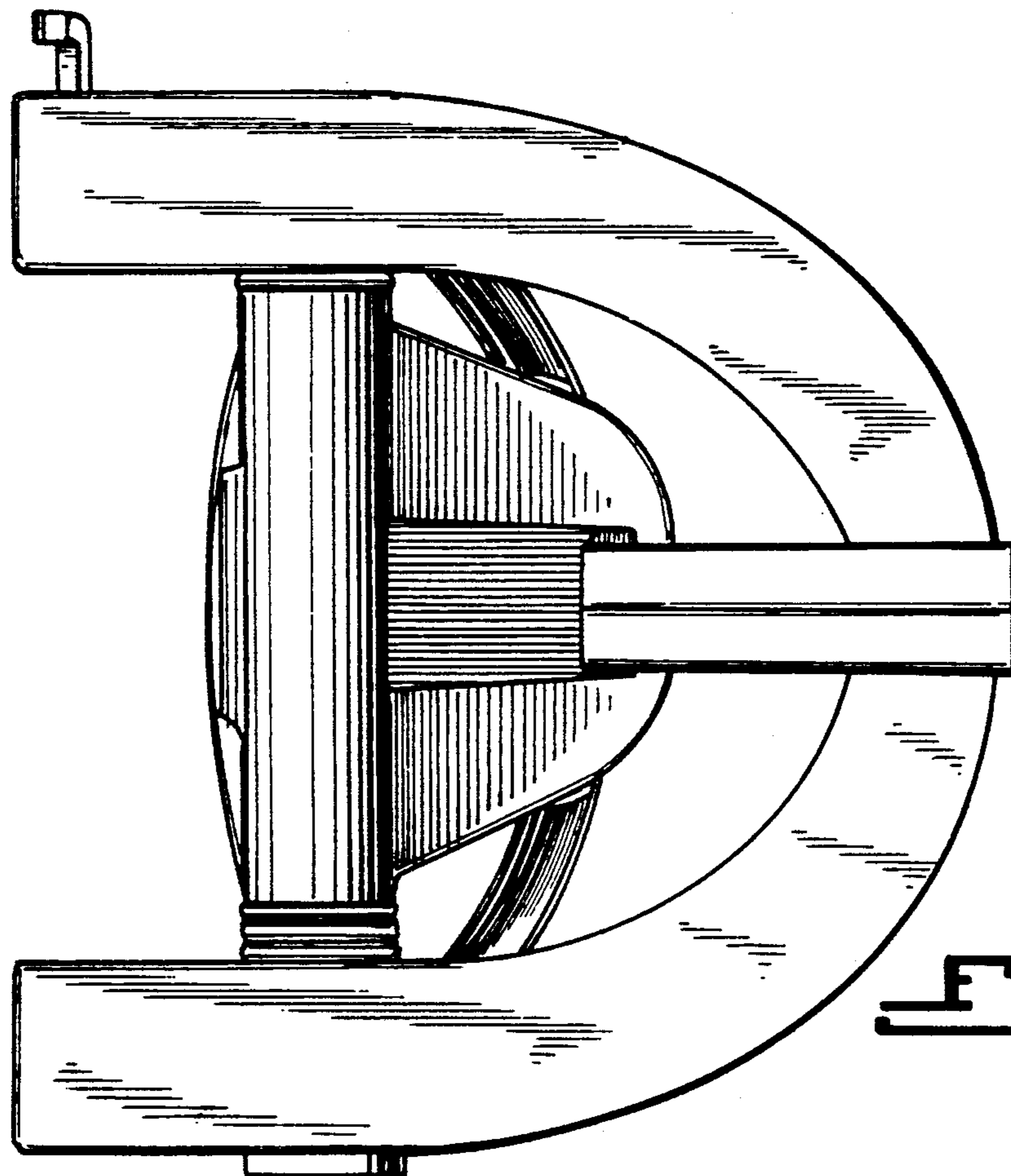
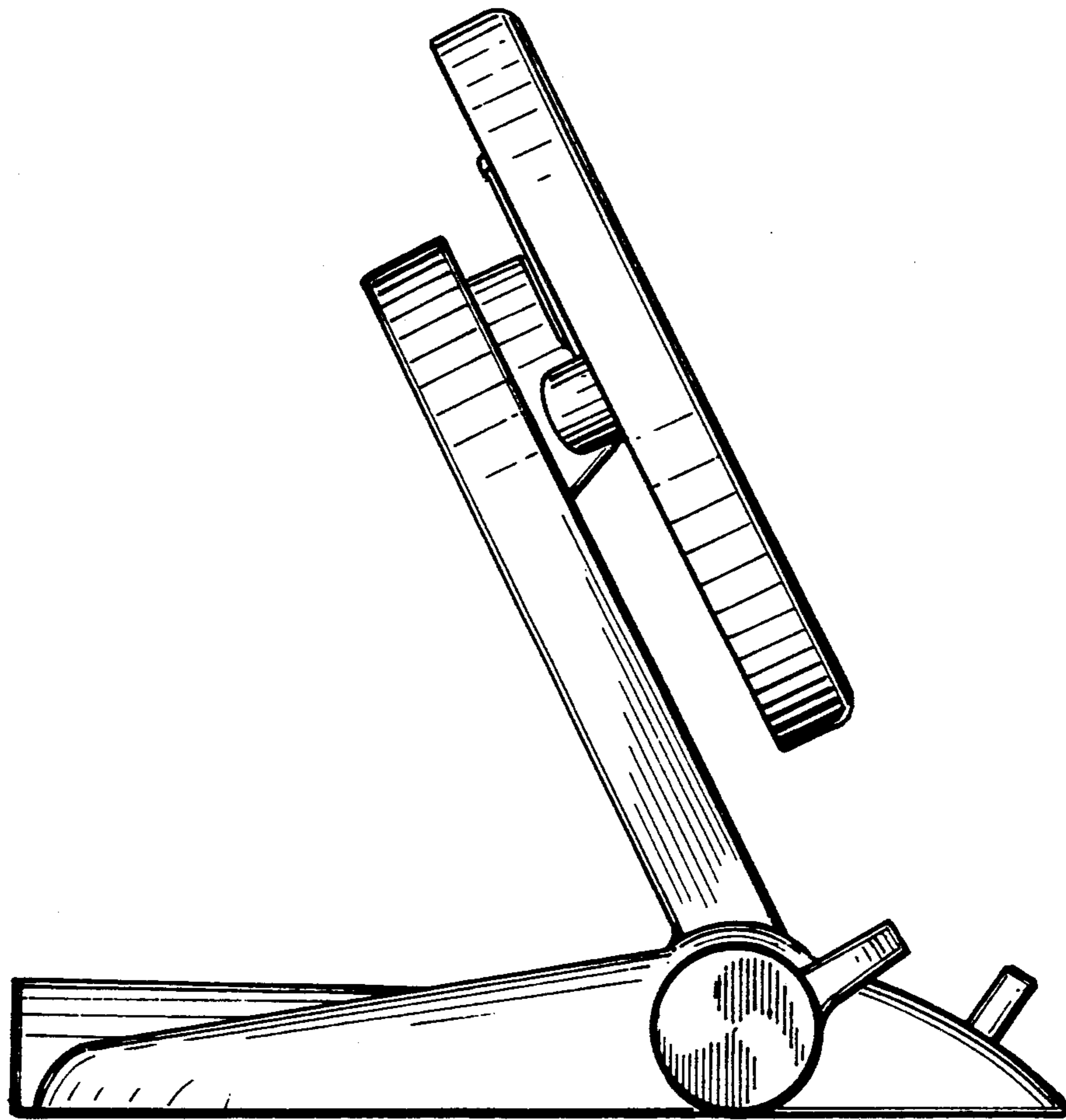
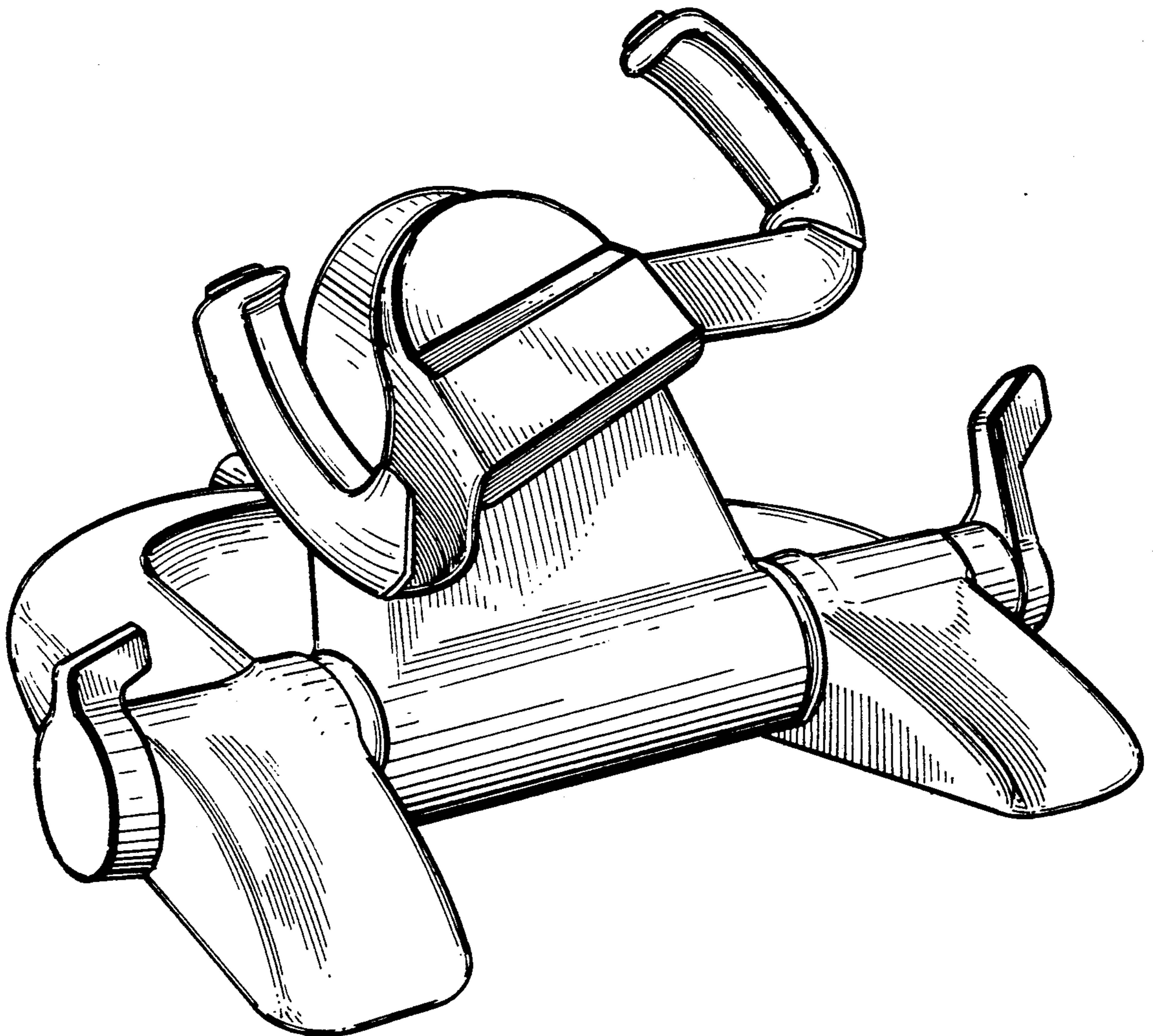

Fig. 4



**Fig. 5**



**Fig. 6**

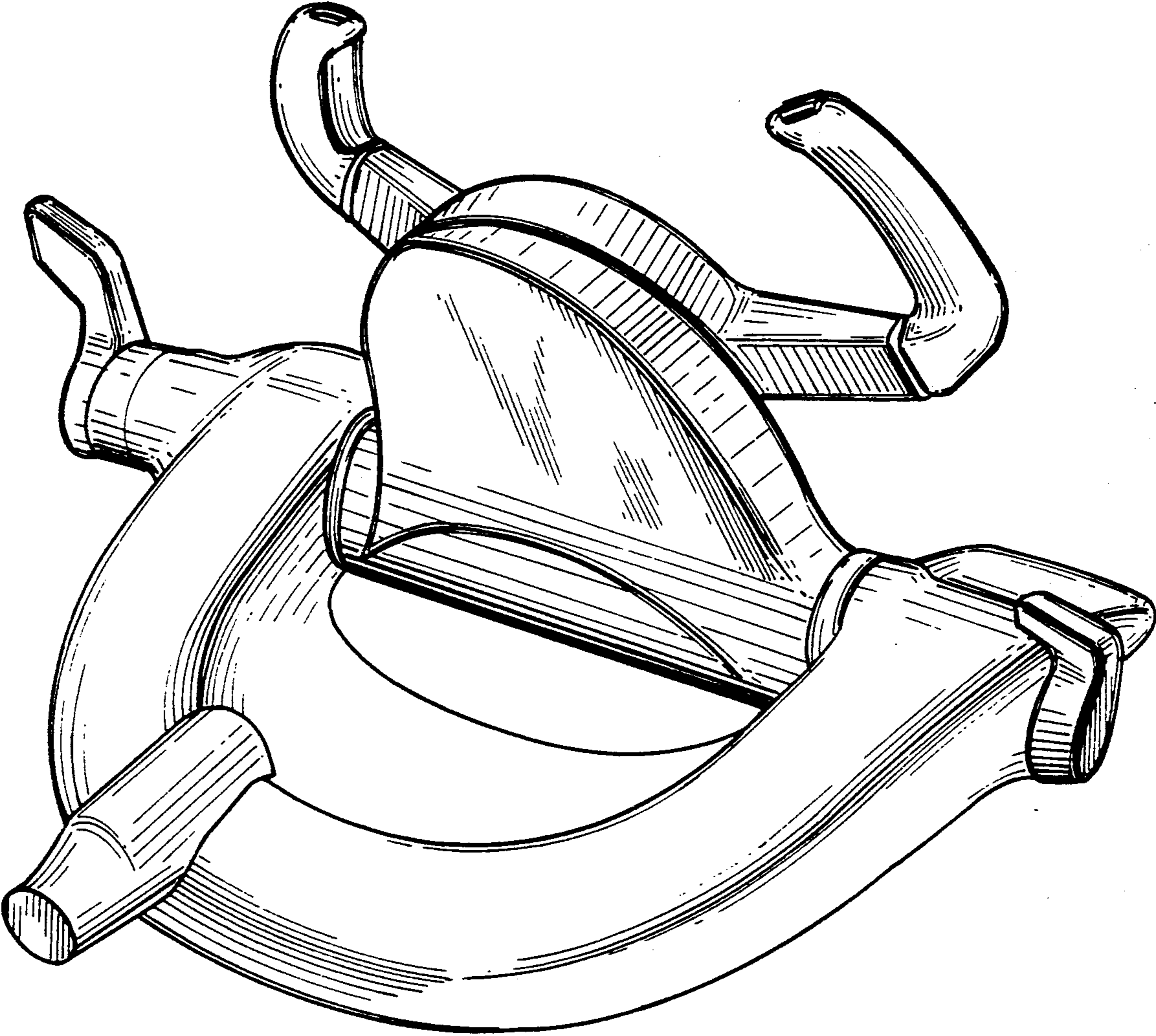

**Fig. 7**

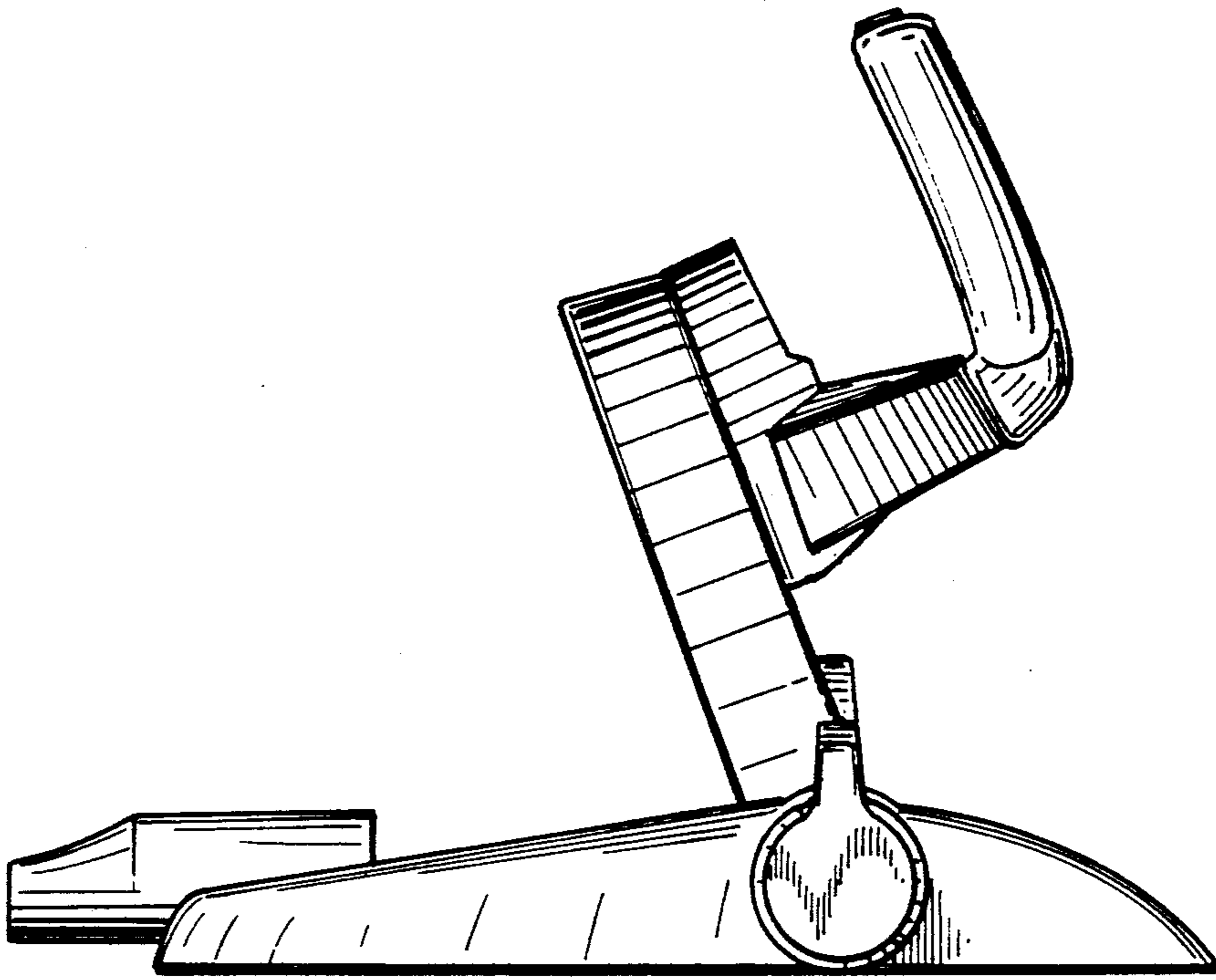

Fig 8

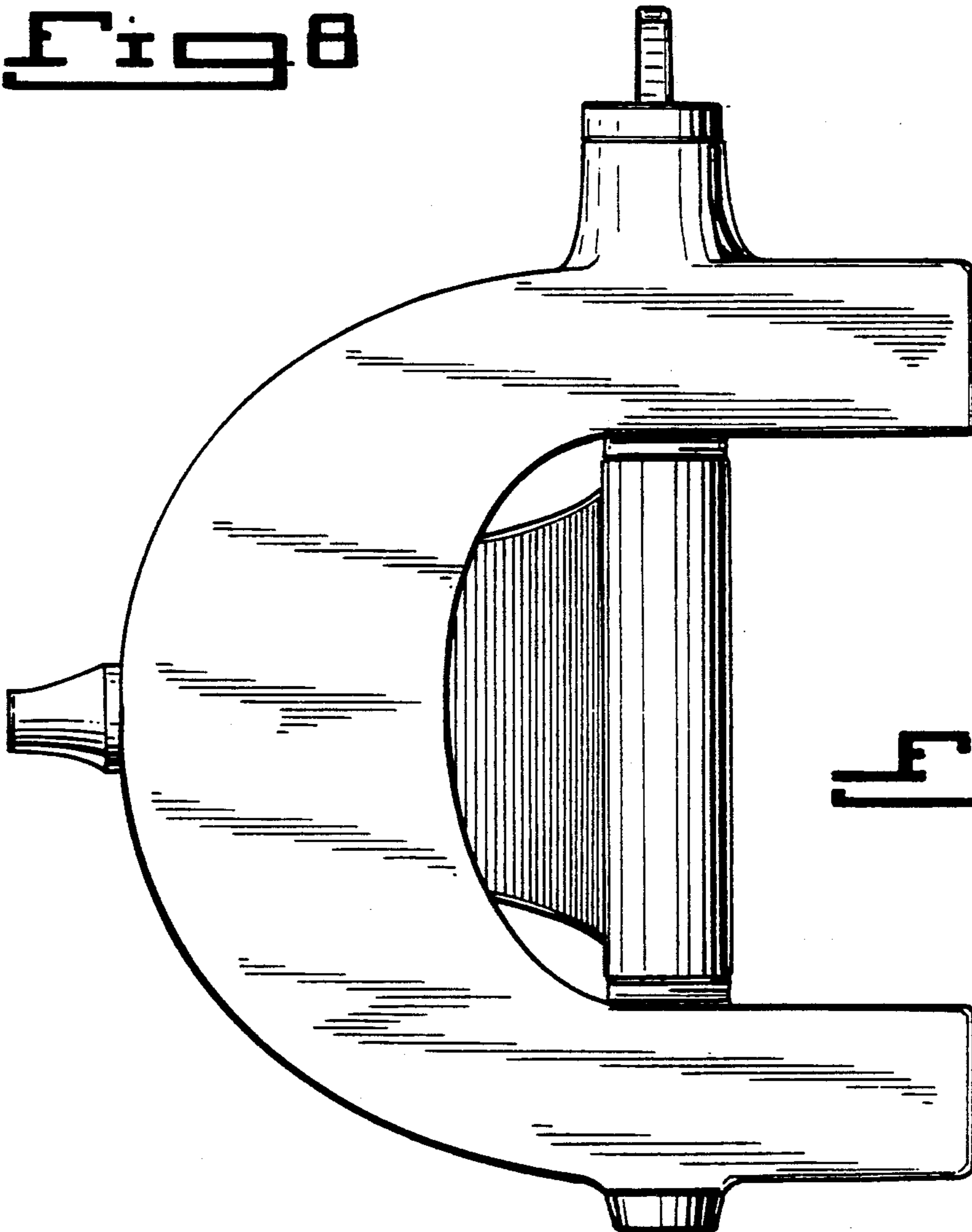
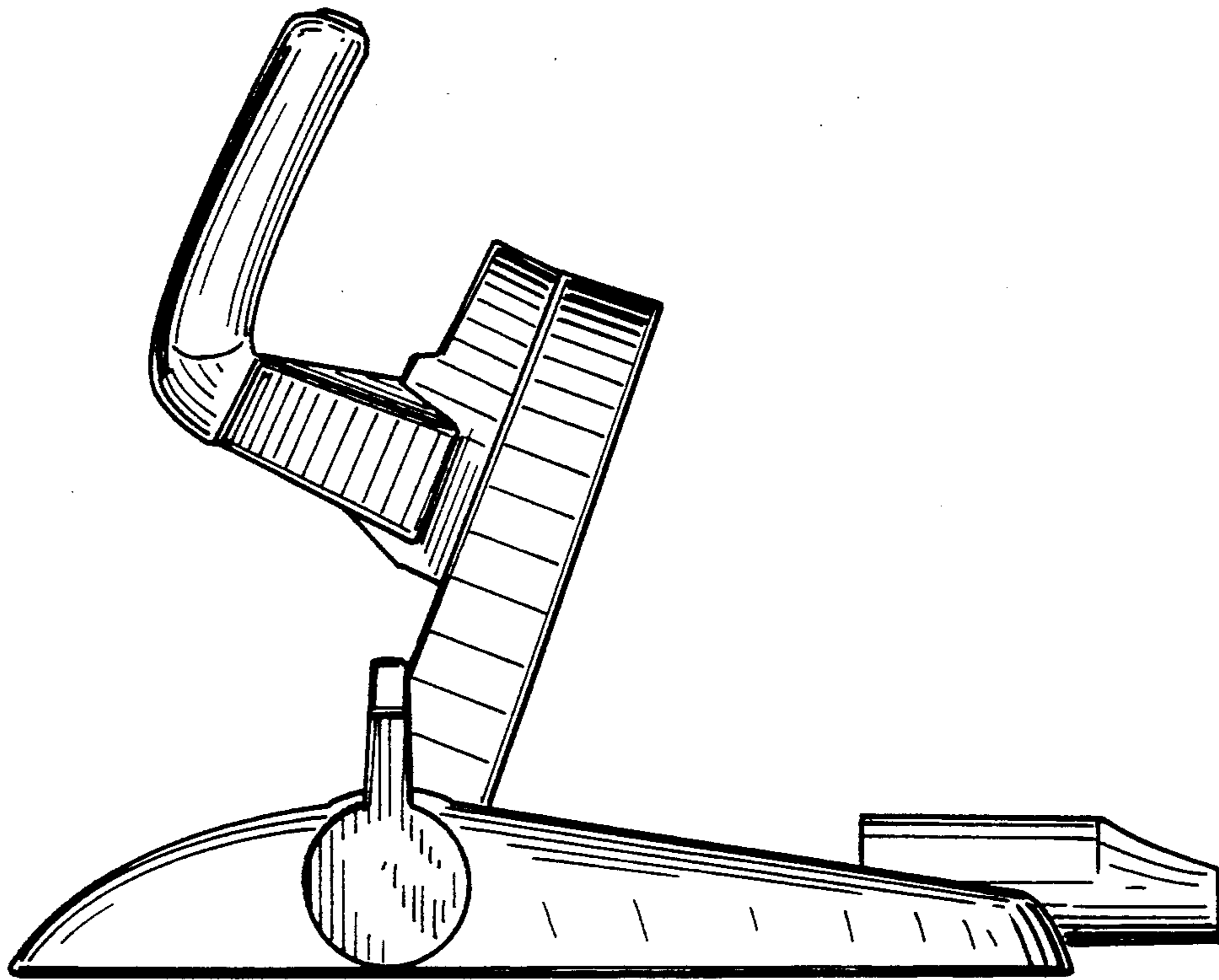
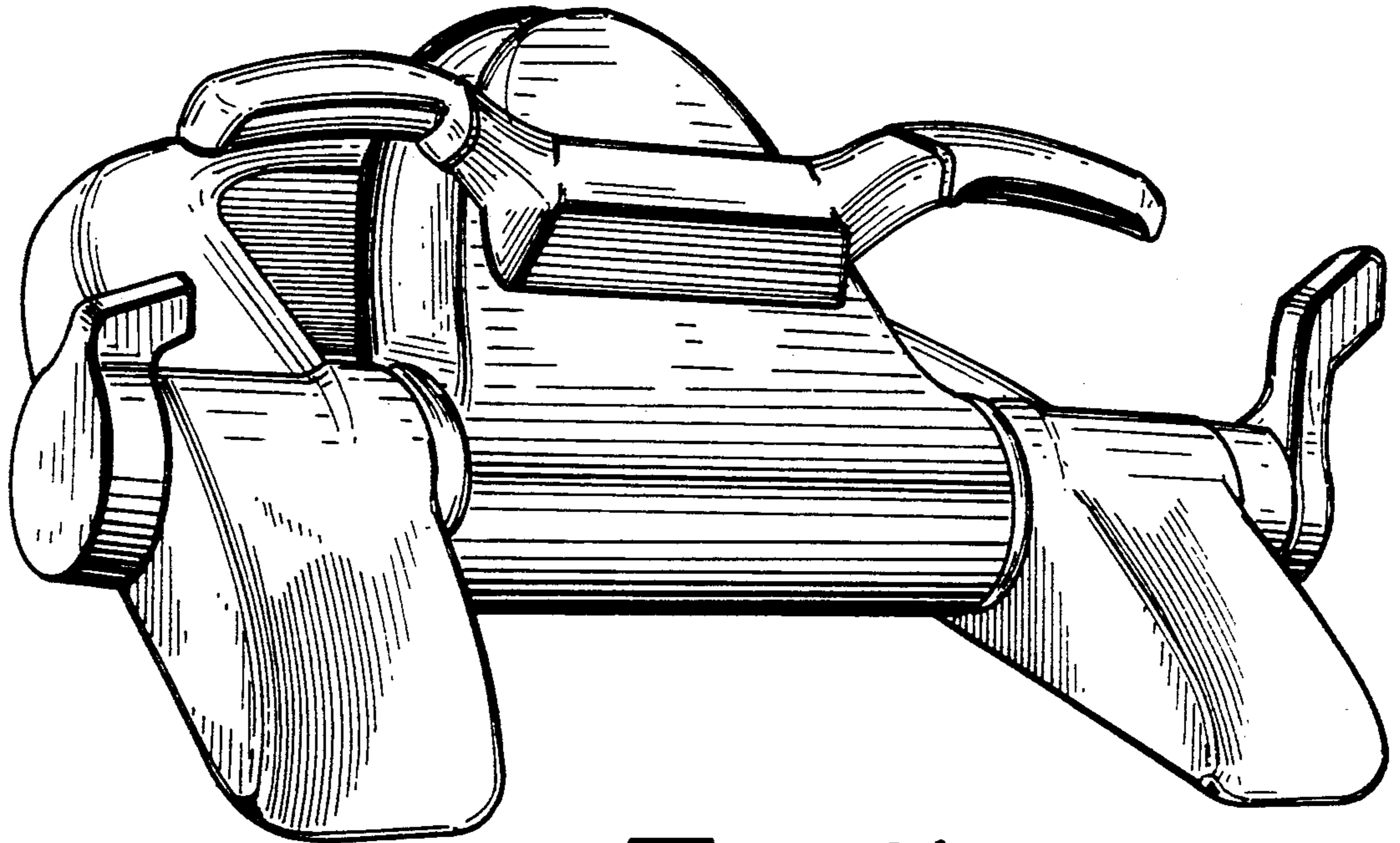

Fig 9

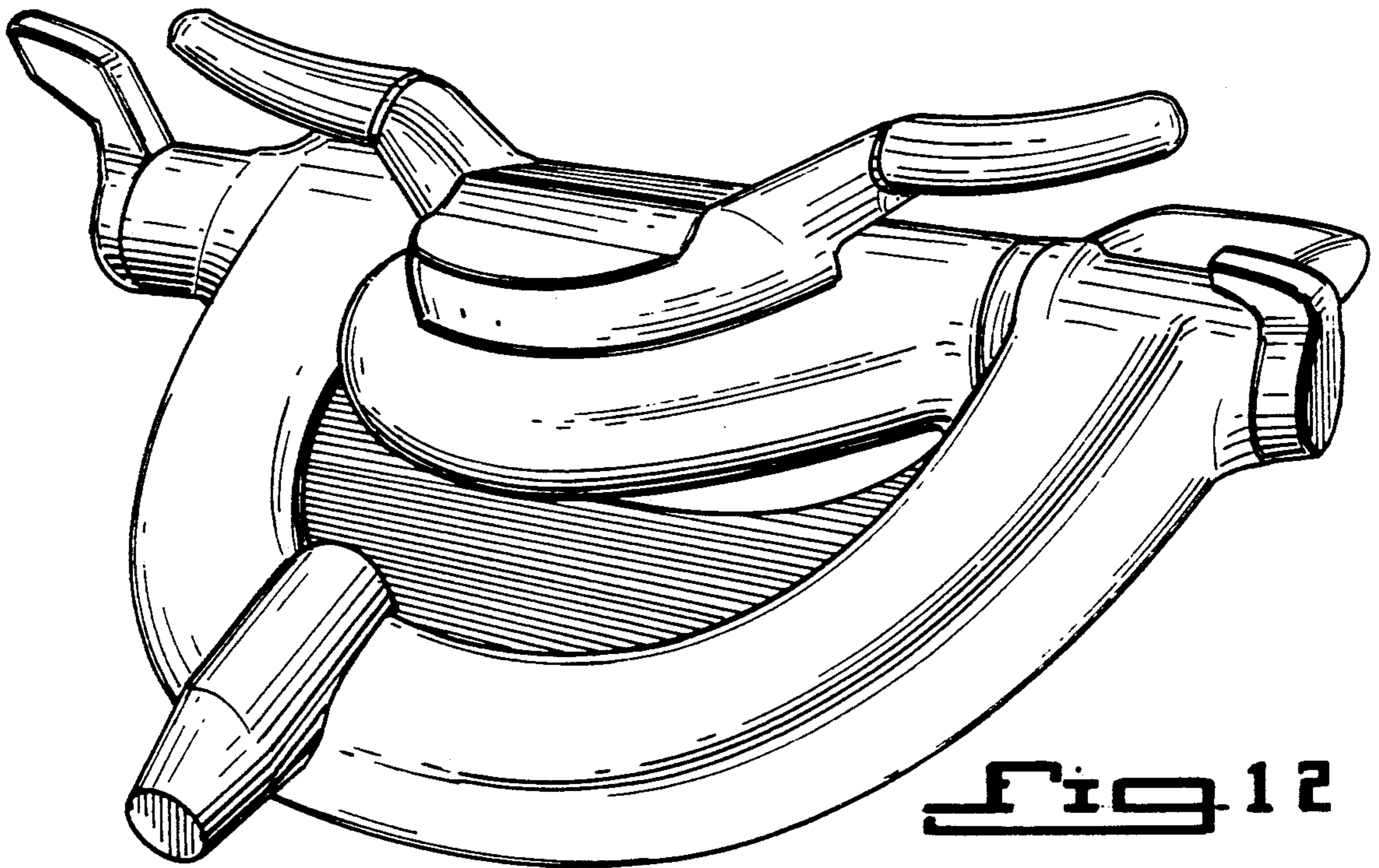



**Fig. 10**



**Fig. 11**



**Fig. 12**

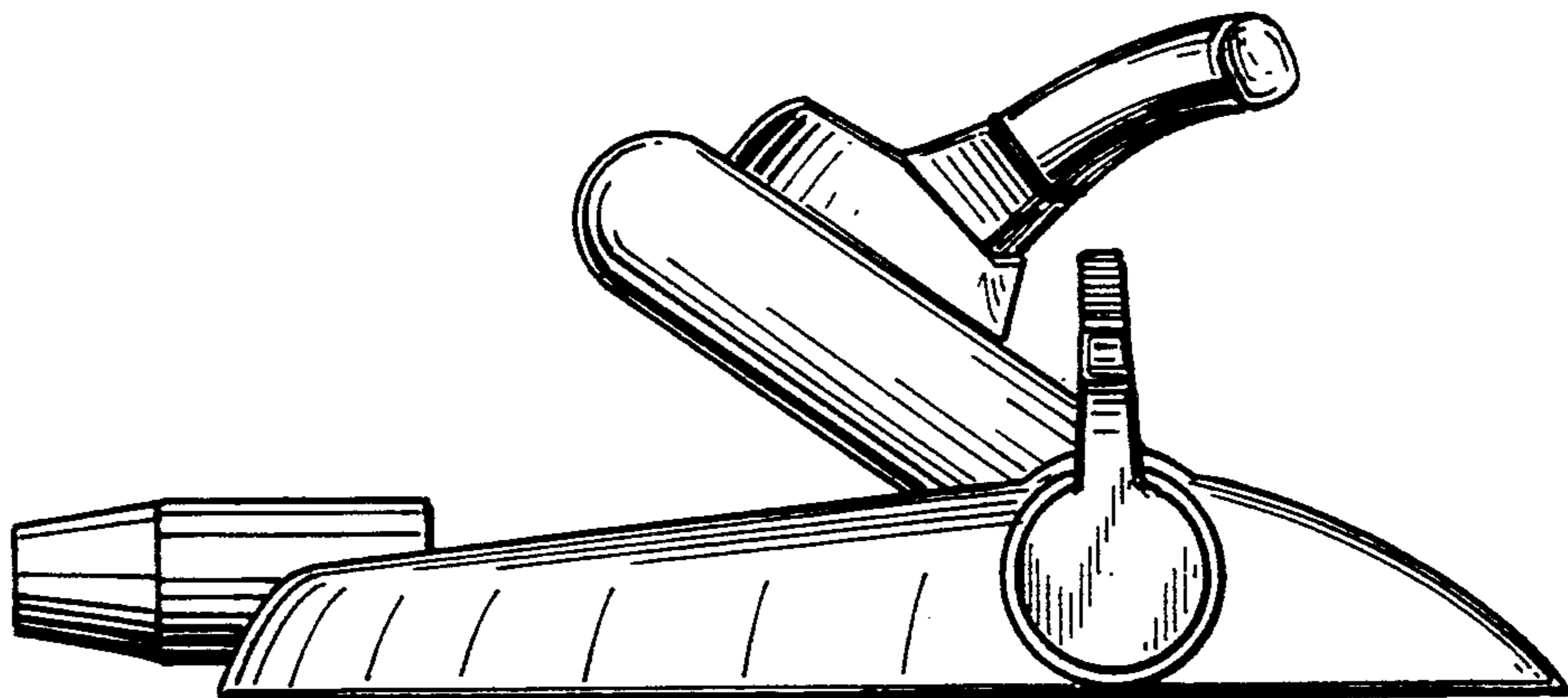

**Fig. 13**

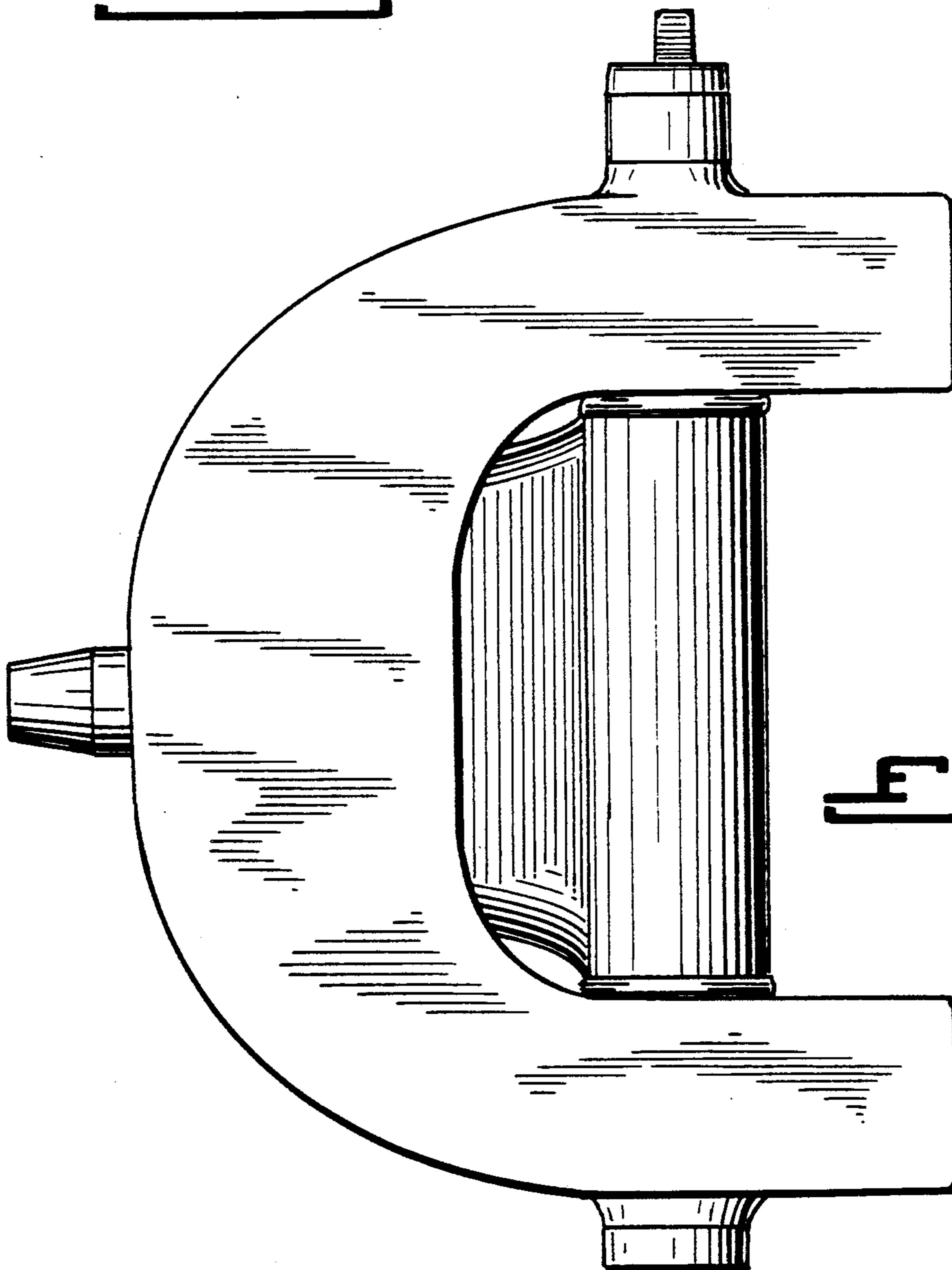

**Fig. 14**

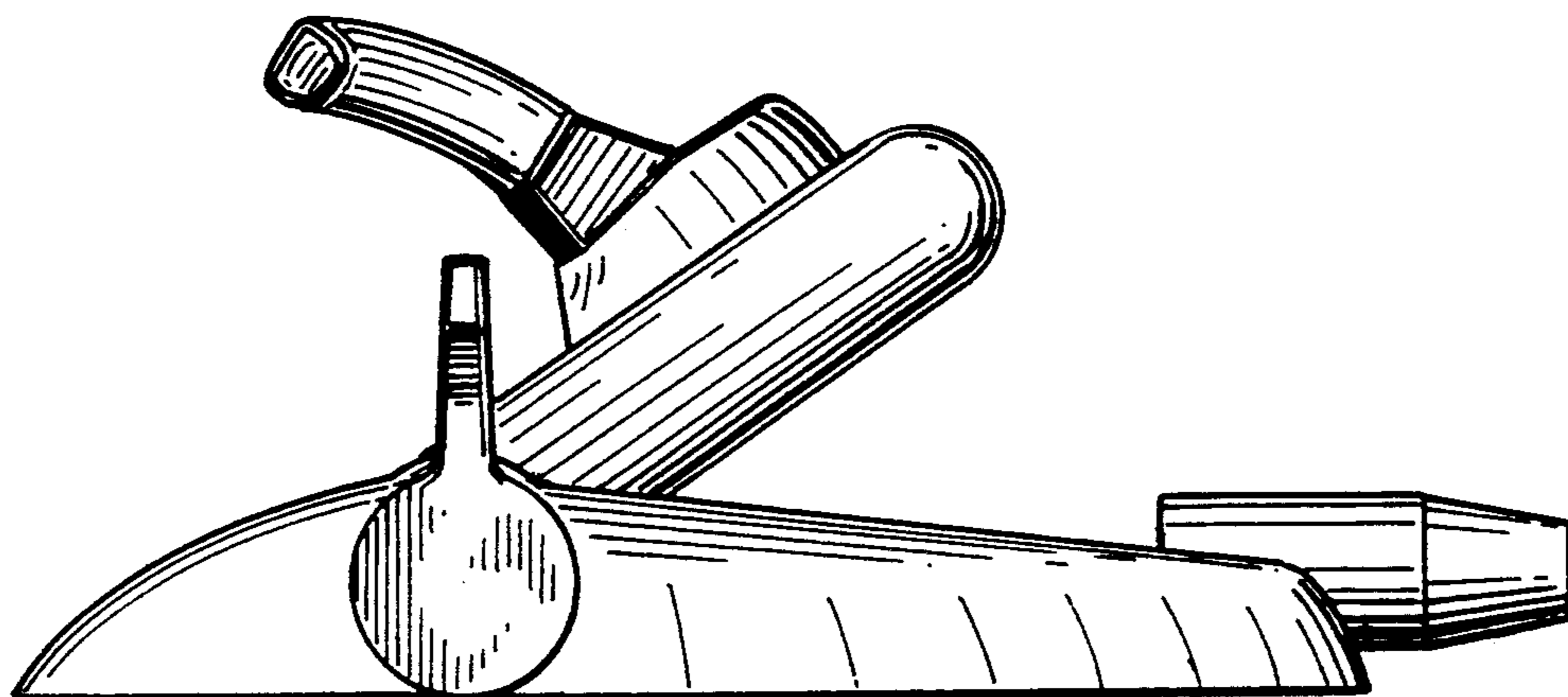

**Fig 15**