

[54] GROUND ENGAGING TREAD ELEMENT FOR A WHEEL OR ENDLESS TRACK

[75] Inventor: Phillip J. Rollinson, Myaree, Australia

[73] Assignee: Altrack Limited, Australia

[\*\*] Term: 14 Years

[21] Appl. No.: 281,232

[22] Filed: Dec. 7, 1988

[30] Foreign Application Priority Data

Jun. 16, 1988 [AU] Australia ..... 1976/88

[52] U.S. Cl. .... D15/28; D12/153

[58] Field of Search ..... D12/135, 149, 151, 153, D12/154; D15/28; 152/209 A, 209 WT, 523; 305/35 R, 35 EB, 39, 53, 56; 180/9.1

[56] References Cited

U.S. PATENT DOCUMENTS

D. 241,734 10/1976 Pfoerther ..... D12/154

D. 285,672	9/1986	Igarashi et al. ....	D12/151
D. 303,779	10/1989	Bonko .....	D12/151
3,895,845	7/1975	Hale .....	305/35 EB
3,950,038	4/1976	Wood .....	180/9.1
4,469,379	9/1984	Kotyuk, Jr. ....	305/35 EB

Primary Examiner—Bernard Ansher  
Assistant Examiner—Sandra Morris  
Attorney, Agent, or Firm—Handal & Morofsky

[57] CLAIM

The ornamental design for a ground engaging tread element for a wheel or endless track, as shown and described.

DESCRIPTION

FIG. 1 is a top perspective view of a ground engaging tread element for a wheel or endless track, showing my new design;

FIG. 2 is a bottom perspective view thereof;

FIG. 3 is a rear elevational view thereof;

FIG. 4 is a front elevational view thereof;

FIG. 5 is a left side elevational view thereof;

FIG. 6 is a top plan view thereof.

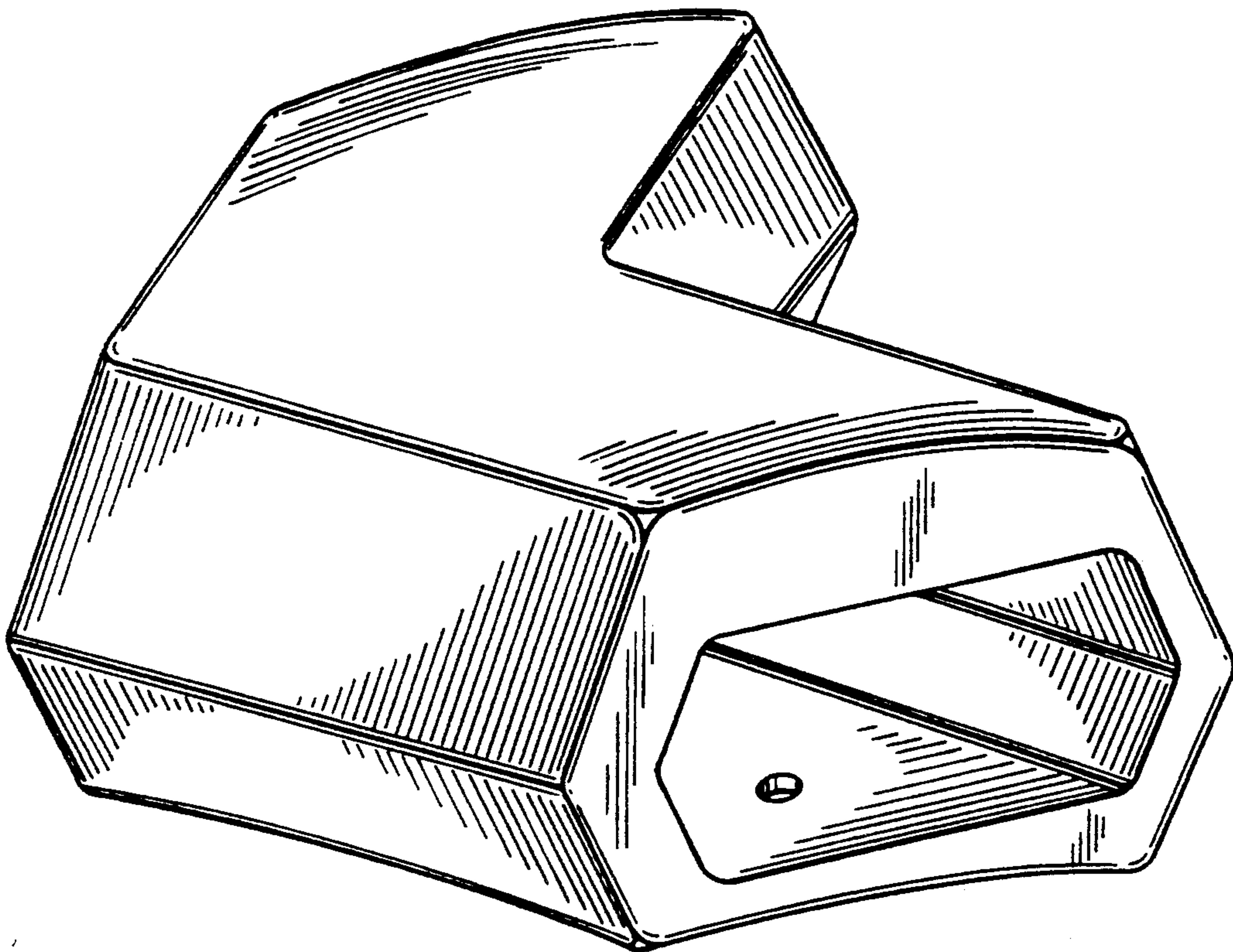

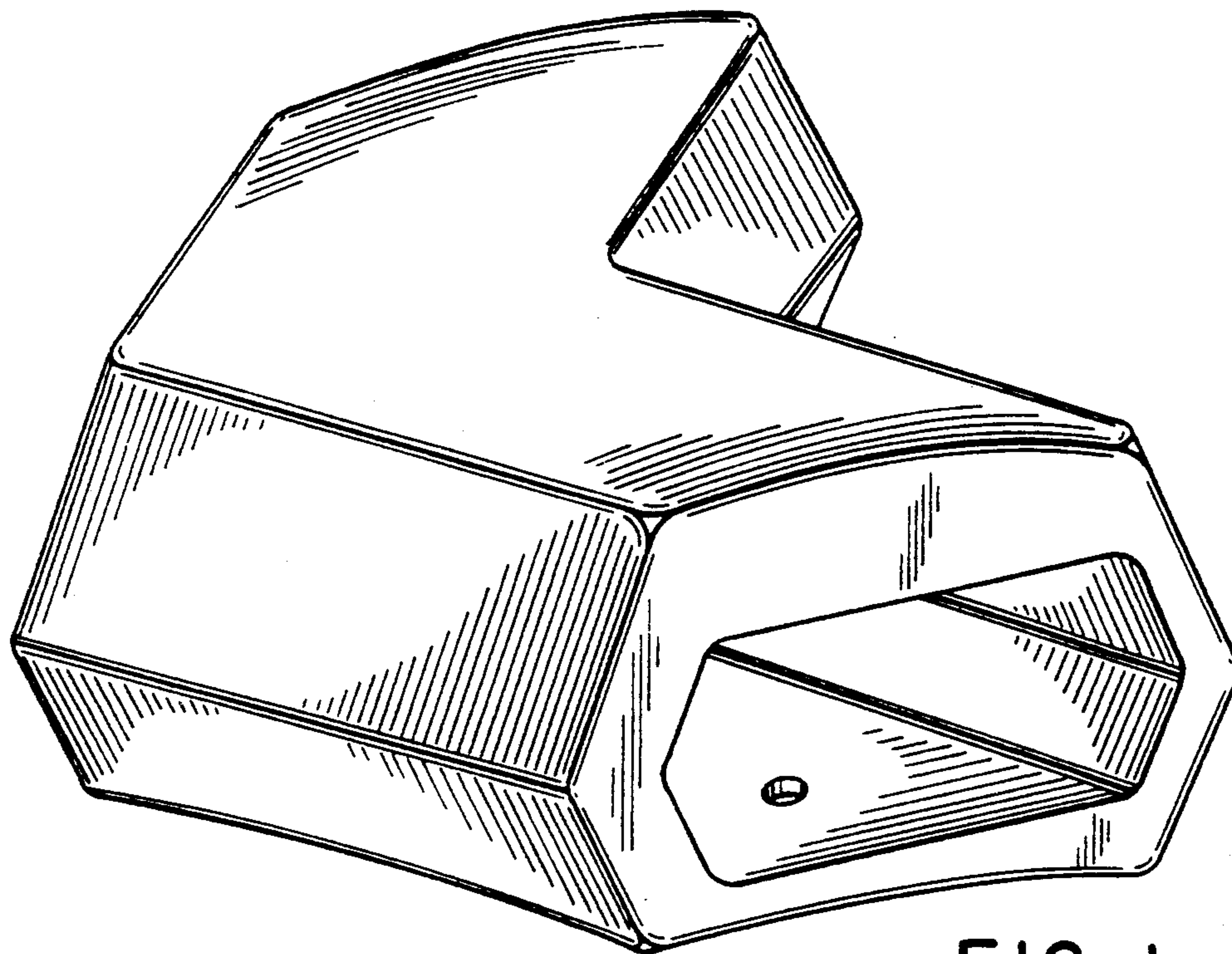

FIG. 1

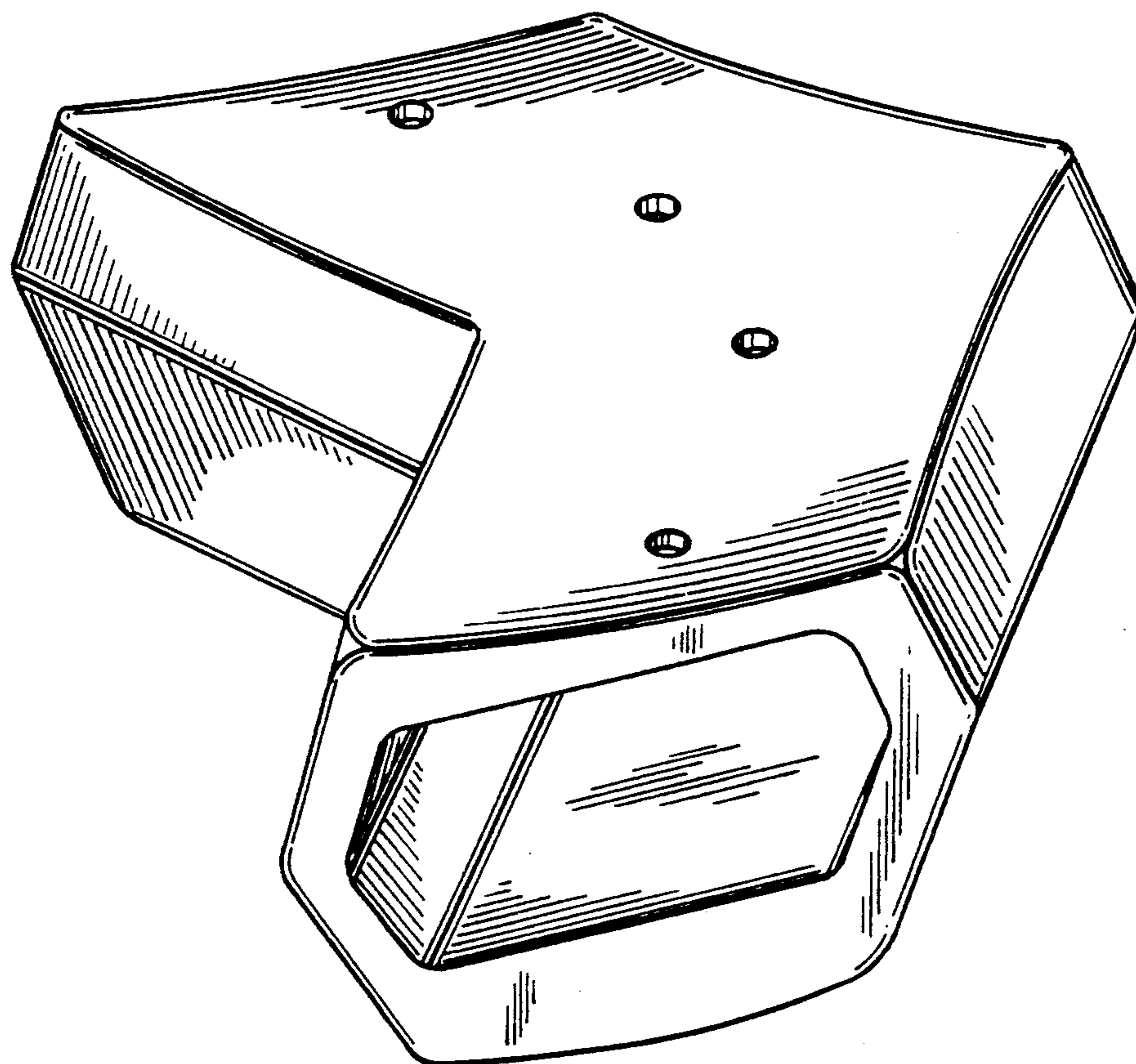

FIG. 2

FIG. 3

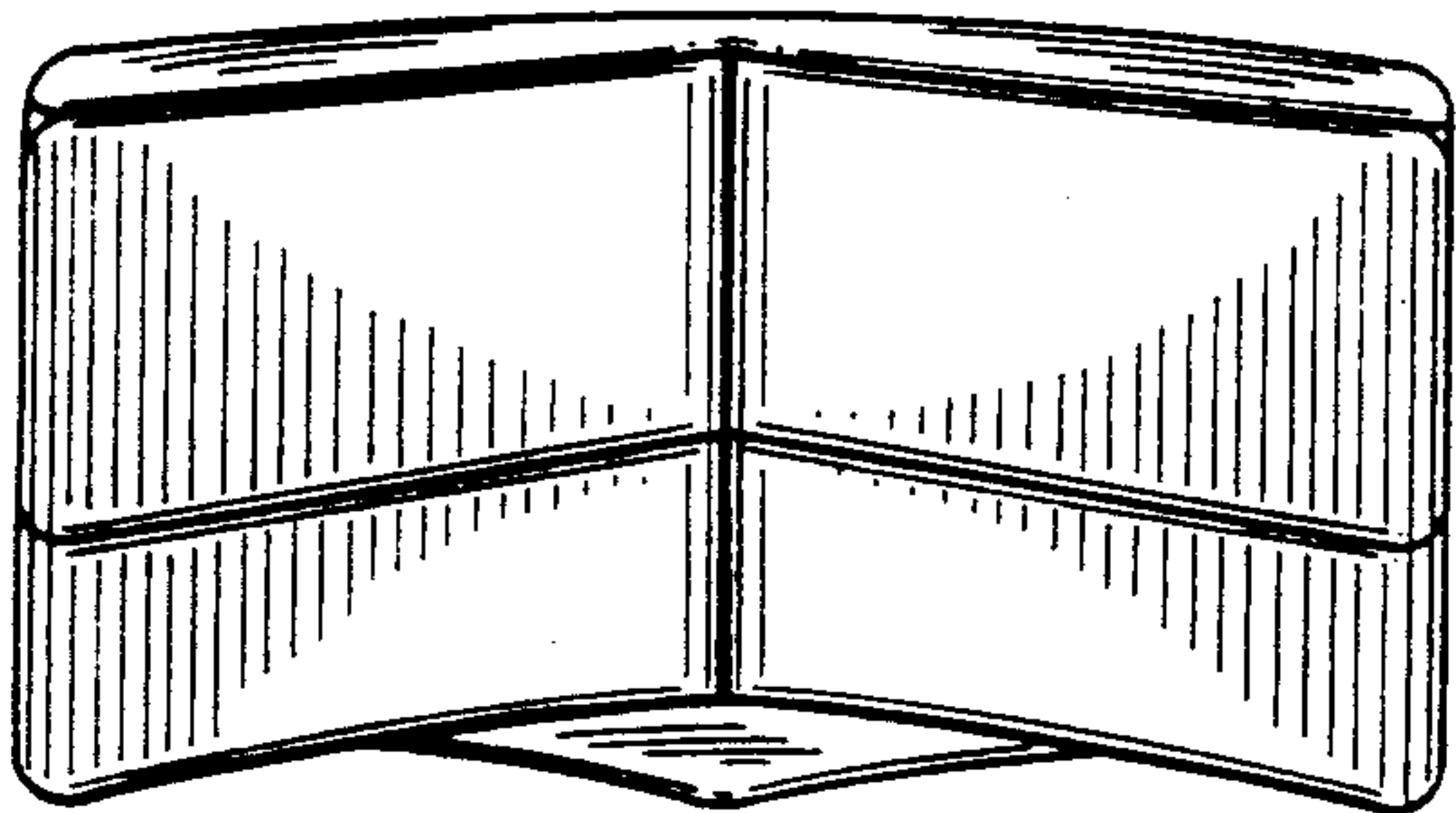

FIG. 4

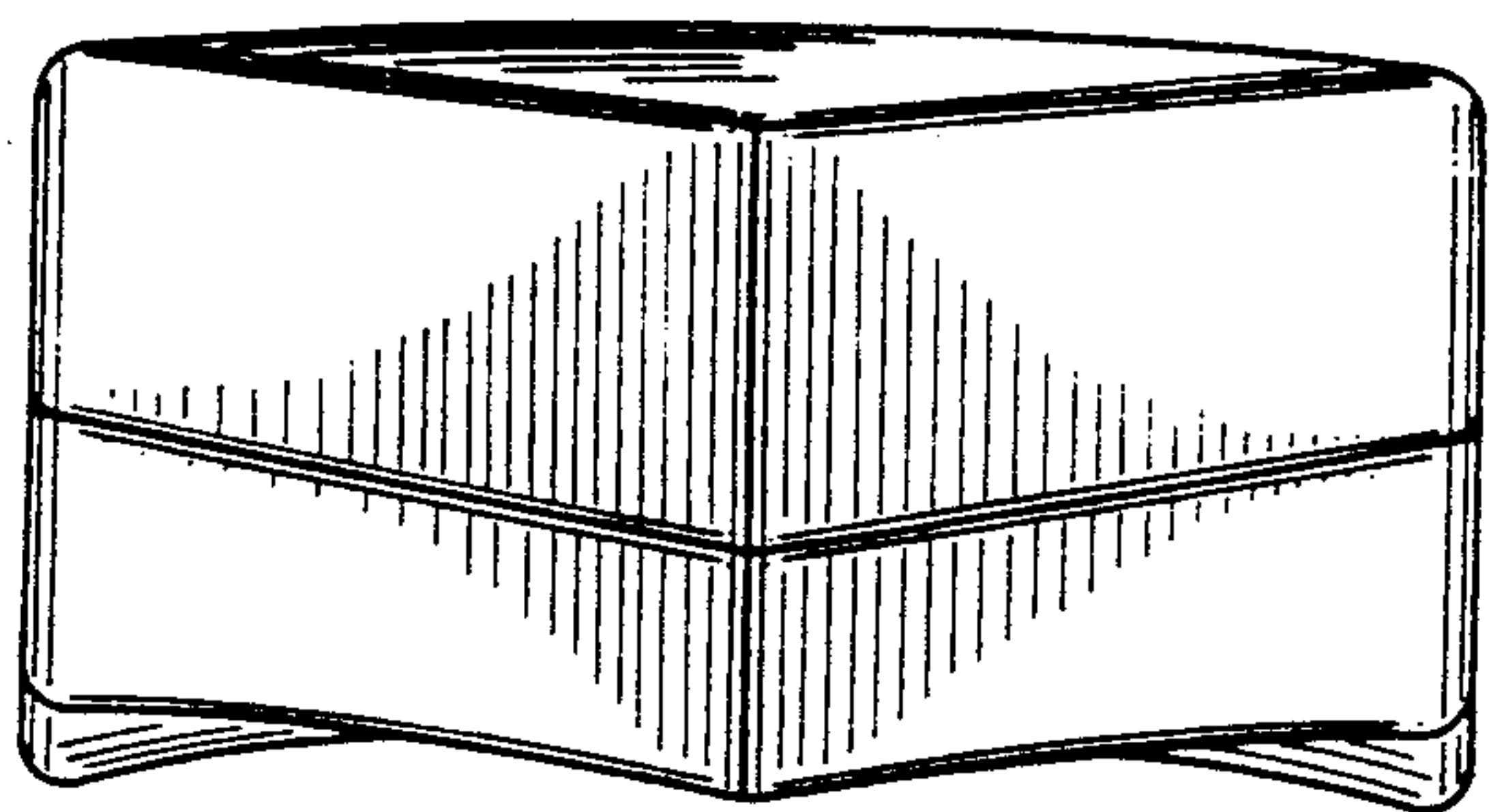

FIG. 5

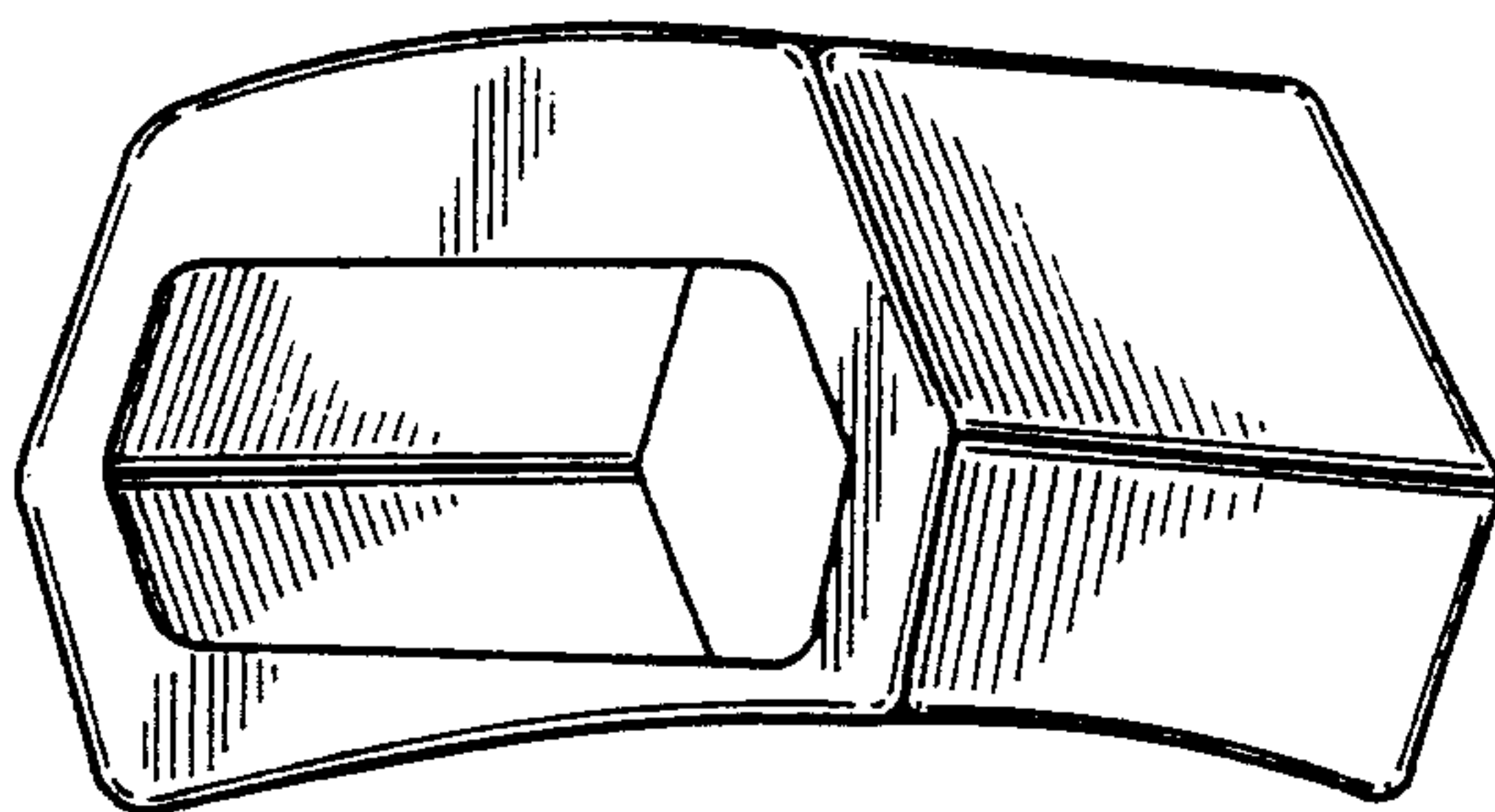

FIG. 6

