

[54] MOTOR-DRIVEN GOLF-BAG CADDY

[76] Inventor: Reinold Alterbaum, Rotdornallee 47, 4840 Rheda-Wiedenbruek, Fed. Rep. of Germany

[**] Term: 14 Years

[21] Appl. No.: 279,189

[22] Filed: Dec. 2, 1988

[52] U.S. Cl. D34/15

[58] Field of Search D34/15; 280/DIG. 5; 180/19.3, 19.1, 65.6

[56] References Cited

U.S. PATENT DOCUMENTS

| | | | | |
|------------|---------|---------------|-------|------------|
| D. 280,943 | 10/1985 | Catford | | D34/15 |
| D. 285,017 | 8/1986 | Zentis et al. | | D34/15 |
| D. 292,039 | 9/1987 | Moore | | D34/15 |
| D. 300,577 | 4/1989 | Pope et al. | | D34/15 |
| 4,657,100 | 4/1987 | Lewis | | 280/DIG. 5 |

OTHER PUBLICATIONS

Golf Digest, Oct. 1986, p. 73, "Powa Kaddy".
 "MOTOCADDY"-Electric Golf Trolley-Redbrook Press Ltd./advertisement prior to 11-14-88.
 "Hi-Tech CADDY" your game will feel better for it/advertisement prior to 11-14-88.
 "HILLCREST"-the world's finest motor caddie/advertisement prior to 11-14-88.
 "KING KADDY"-only the best is good enough/advertisement prior to 11-14-88, King Kaddy Ltd.

"POWAKADDY" meet the master of the fairways/advertisement prior to 11-14-88.

"BULL BUGGY"/advertisement prior to 11-14-88.

"L.I.T.E.W.A.T.E"-LiteWate Golf Ltd./advertisement, prior to 11-14-88.

"GREEN CRUISER TROLLEY"/advertisement, prior to 11-14-88.

"ELECTRA CADDIE" Worcester Power Products Ltd./advertisement prior to 11-14-88.

"SUPATROL"/Golf World Industry News, p. 25/advertisement prior to 11-14-88.

"AUTOCADDY" The Better Electric Trolley/advertisement, prior to 11-14-88.

"POWRMATIC" Golf World Industry News, p. 28/advertisement prior to 11-14-88.

"GOPHER #1" Golf World Industry News/advertisement prior to 11-14-88.

Primary Examiner—Kay H. Chin

Attorney, Agent, or Firm—Griffin Branigan & Butler

[57] CLAIM

The ornamental design for a motor-driven golf-bag caddy, as shown.

DESCRIPTION

FIG. 1 is a right and front perspective view of a motor-driven golf bag caddy showing my new design;
 FIG. 2 is a left side elevational view thereof;
 FIG. 3 is a top plan view thereof;
 FIG. 4 is a bottom plan view thereof;
 FIG. 5 is a front elevational view thereof; and
 FIG. 6 is a rear elevational view thereof.

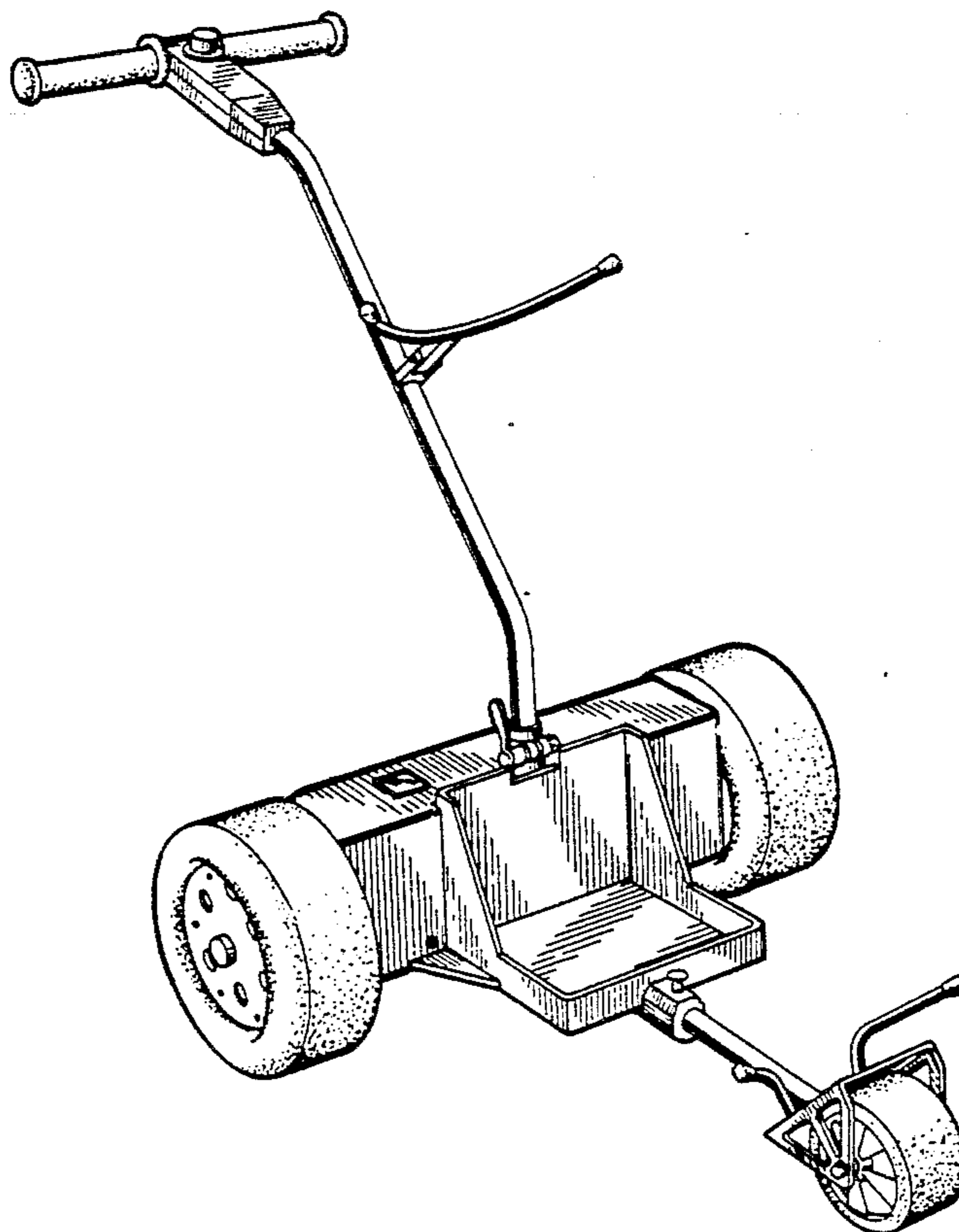

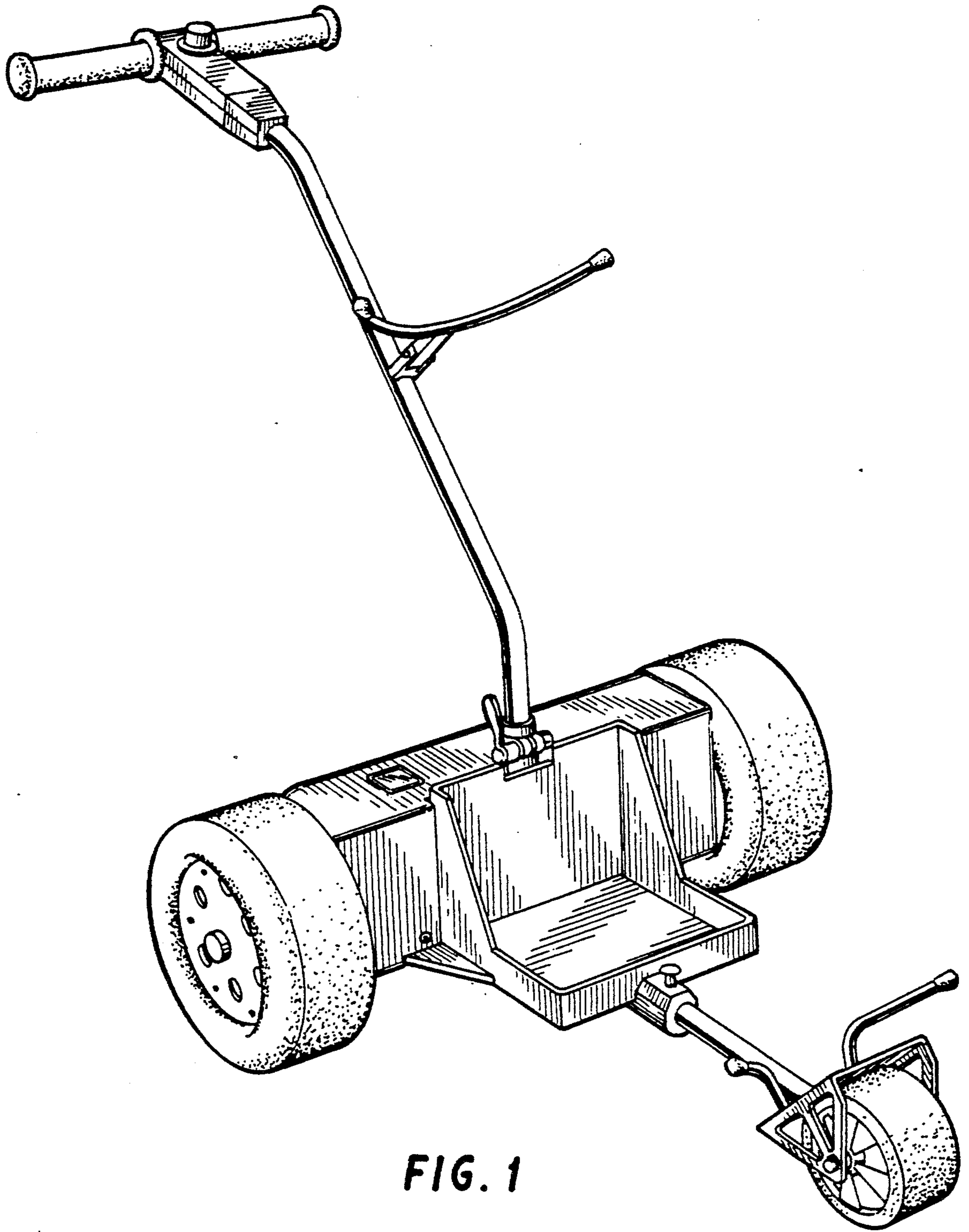

FIG. 1

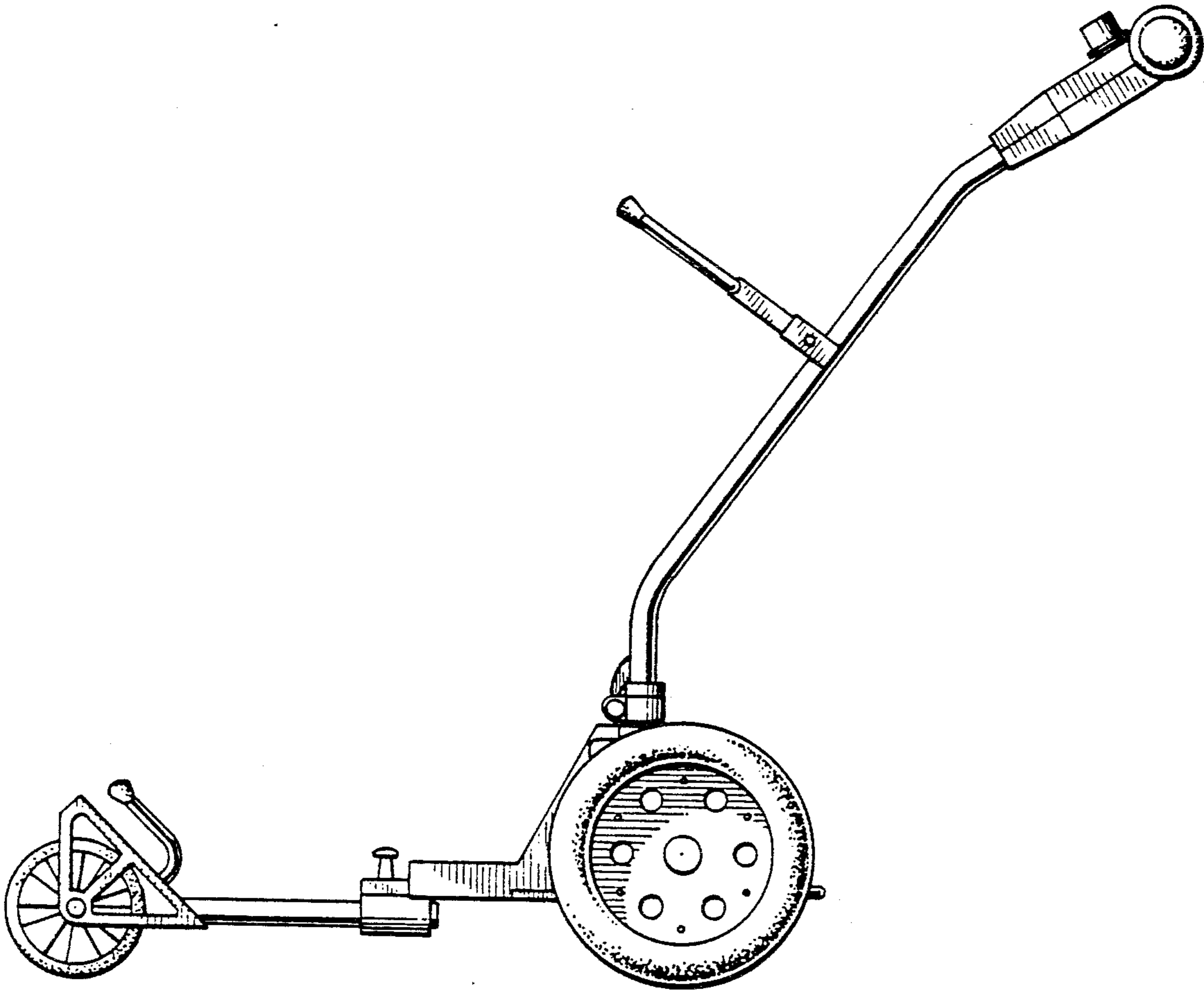

FIG. 2

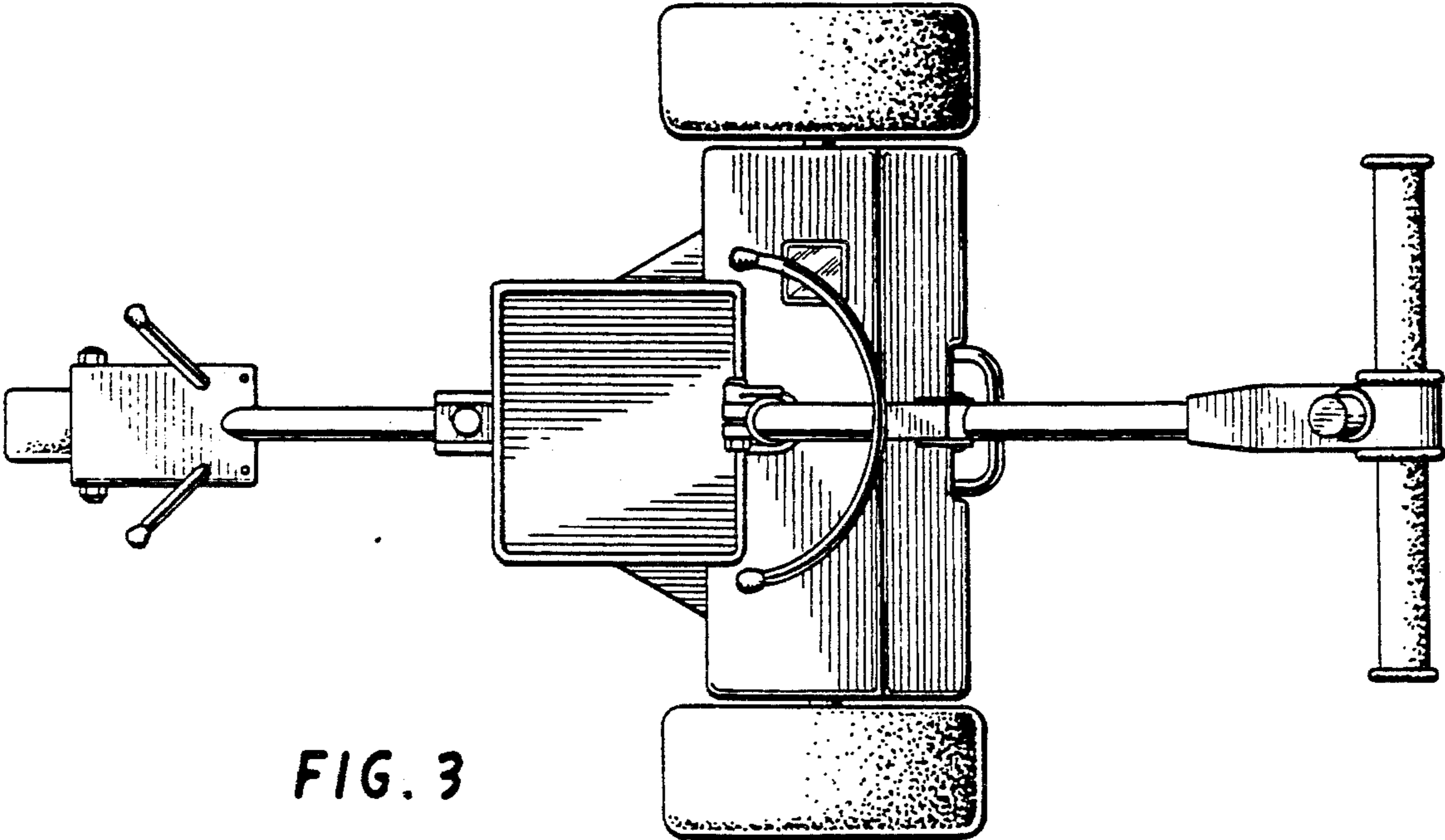

FIG. 3

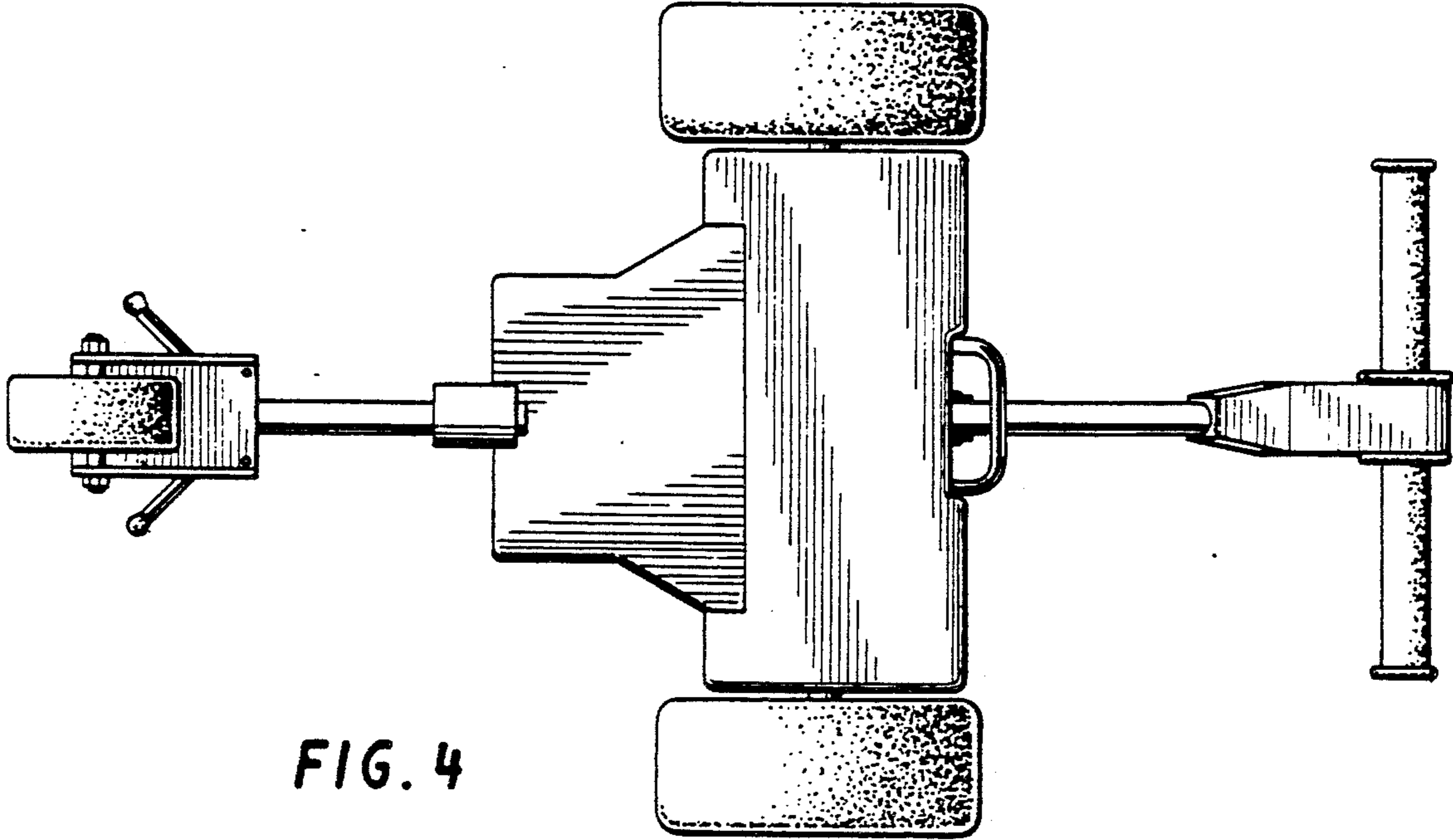

FIG. 4

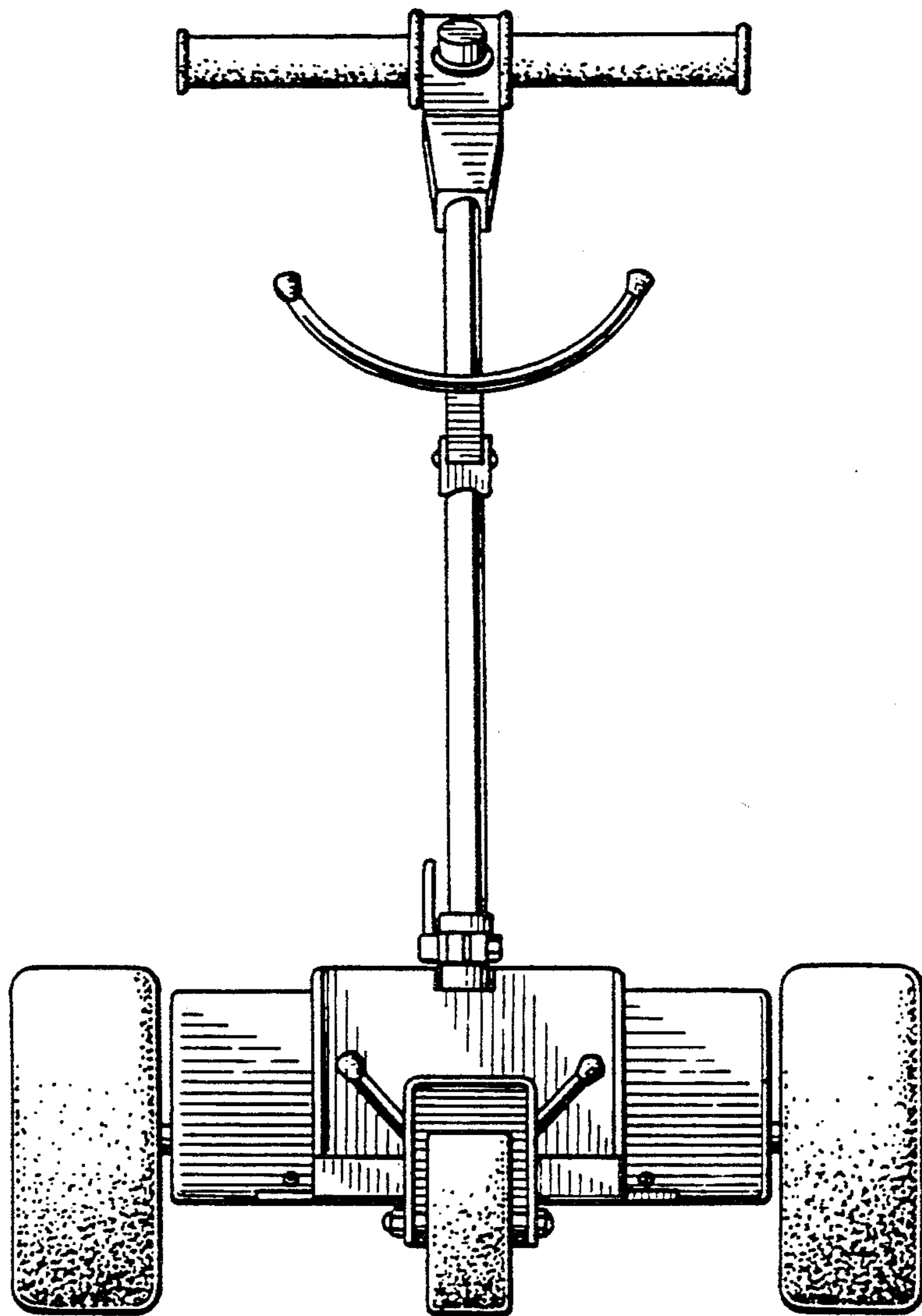

FIG. 5

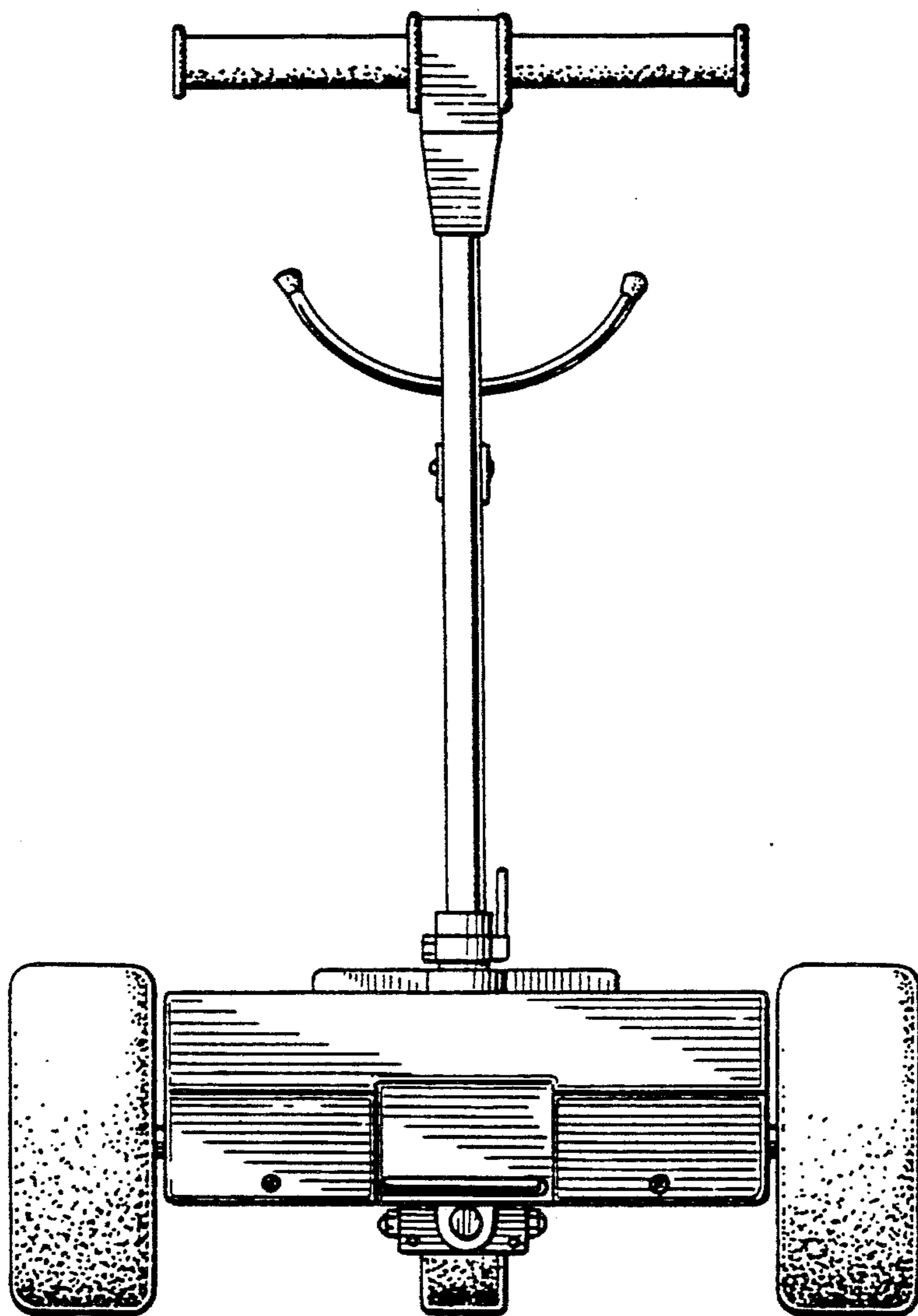

FIG. 6