

[54] REAR LIGHT FOR AN AUTOMOBILE

[75] Inventors: Stig F. O. Falck, Bohus Björköö;
Frans G. Falck, Torslanda, both of
Sweden

[73] Assignee: Aktiebolaget Volvo, Gothenburg,
Sweden

[**] Term: 14 Years

[21] Appl. No.: 368,538

[22] Filed: Jun. 20, 1989

[52] U.S. Cl. D26/35

[58] Field of Search D26/28-36,
D26/120, 122; 362/61, 80, 80.1, 81, 82, 83, 83.2,
83.3, 267, 326, 334

[56] References Cited

U.S. PATENT DOCUMENTS

D. 293,938 1/1988 Soma D26/28

D. 295,899 5/1988 Ienaga et al. D26/28
4,796,165 1/1989 Metti 362/80

Primary Examiner—Susan J. Lucas
Attorney, Agent, or Firm—Young & Thompson

[57] CLAIM

The ornamental design for a rear light for an autom-
obile, as shown and described.

DESCRIPTION

FIG. 1 is a front elevational view of a rear light for an
automobile showing our new design;

FIG. 2 is a rear elevational view thereof;

FIG. 3 is a side elevational view thereof as seen from
the right hand side of FIG. 1;

FIG. 4 is a side elevational view thereof as seen from
the left hand side of FIG. 1;

FIG. 5 is a front, right hand side perspective view
thereof;

FIG. 6 is a bottom, front perspective view thereof.

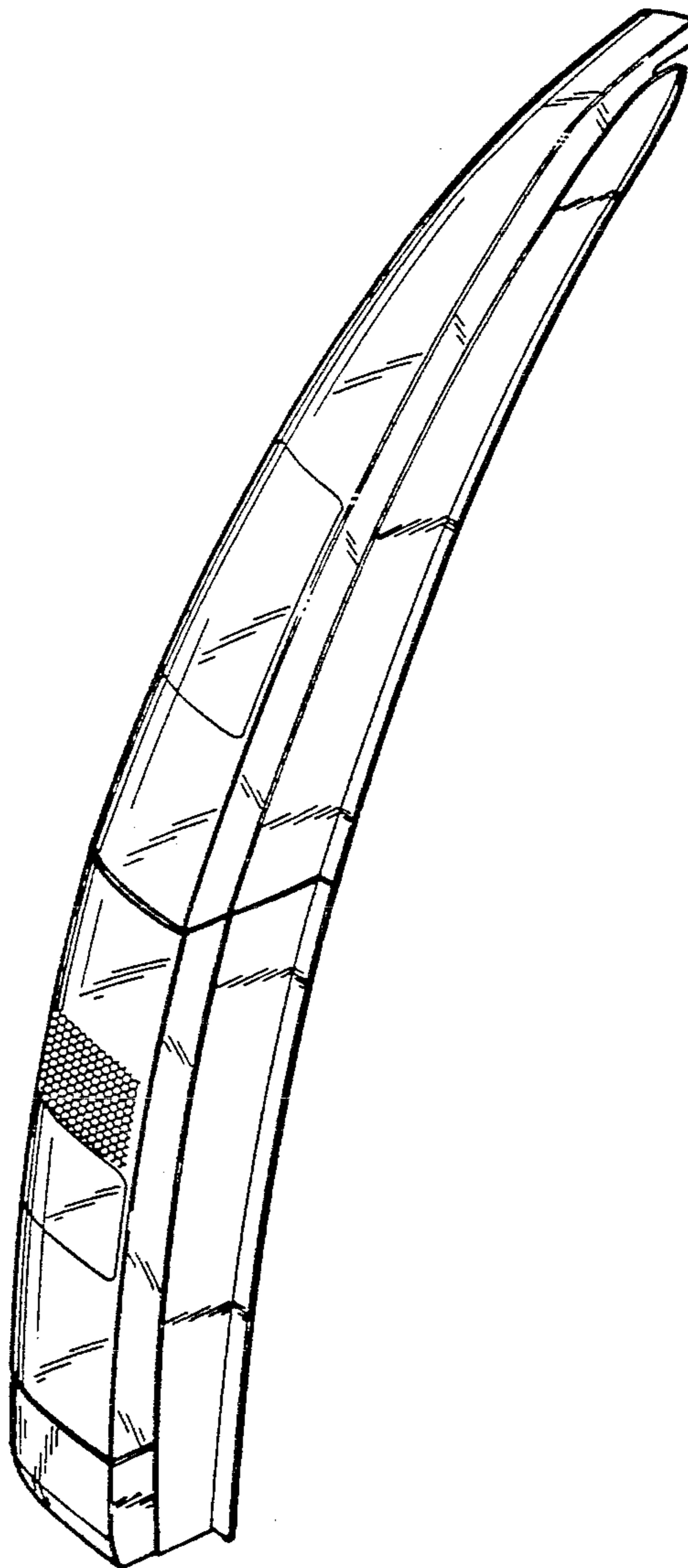

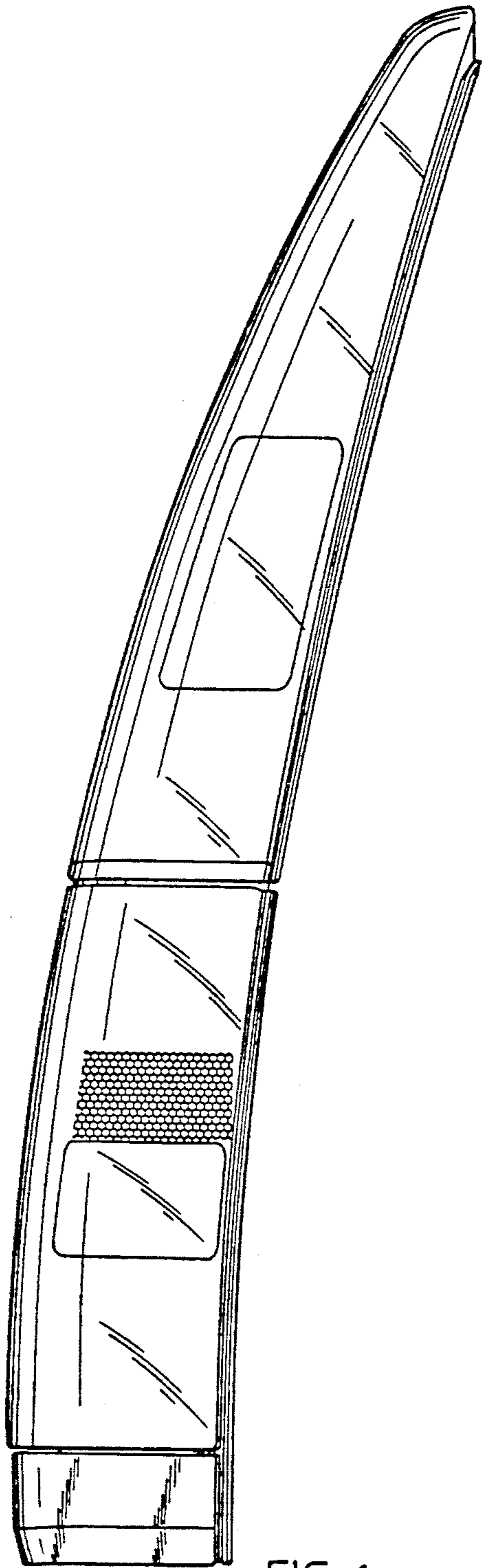

FIG. 1

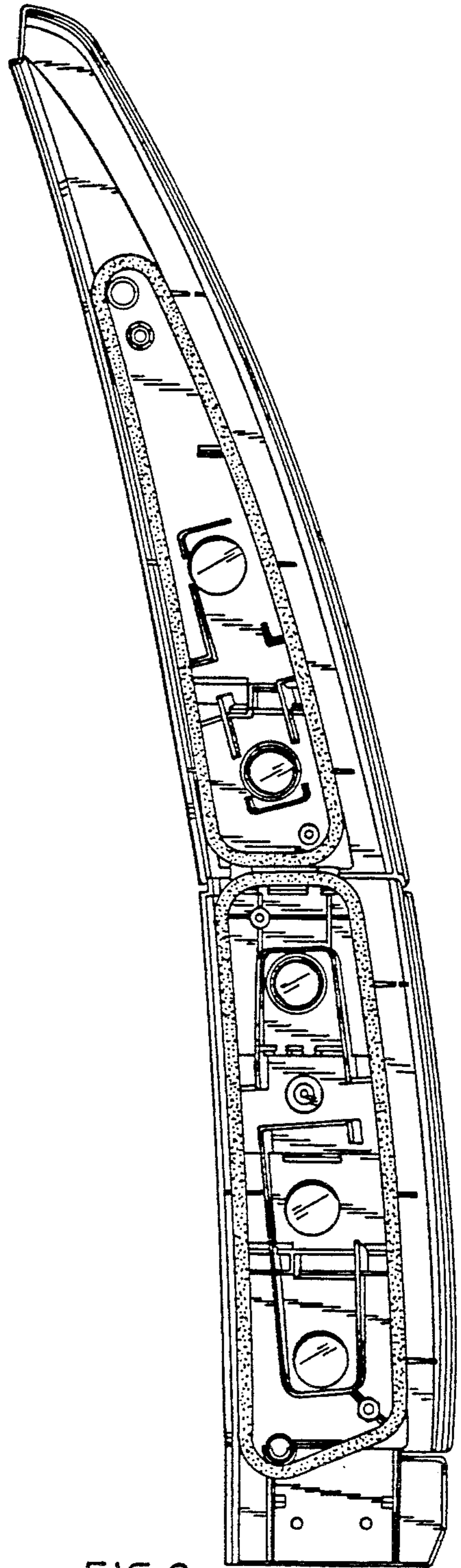

FIG. 2

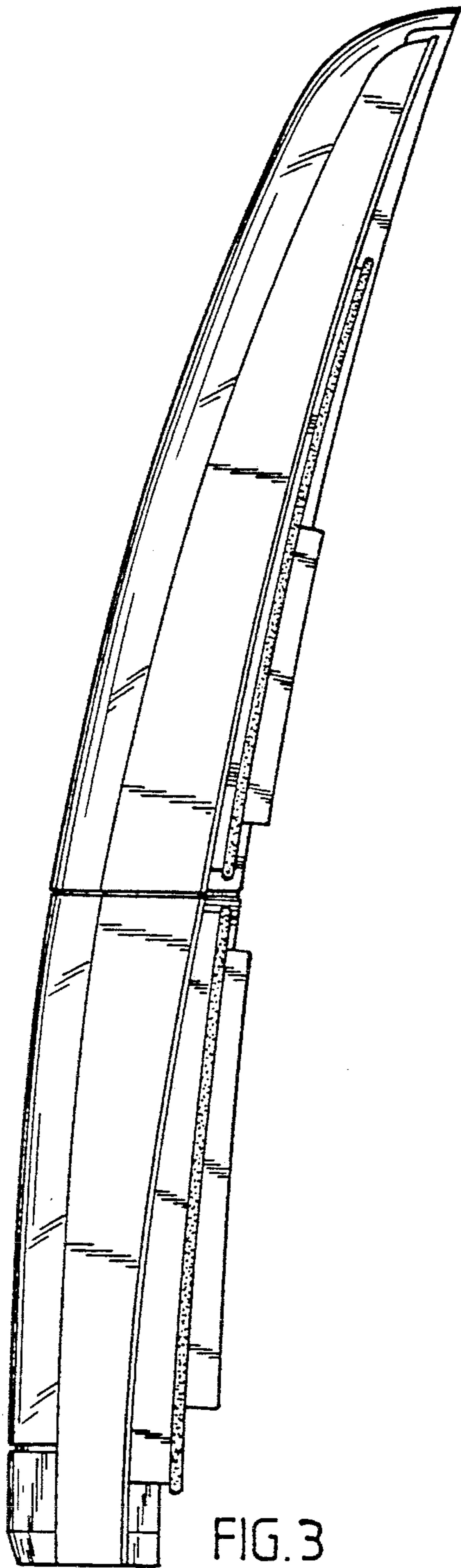

FIG. 3

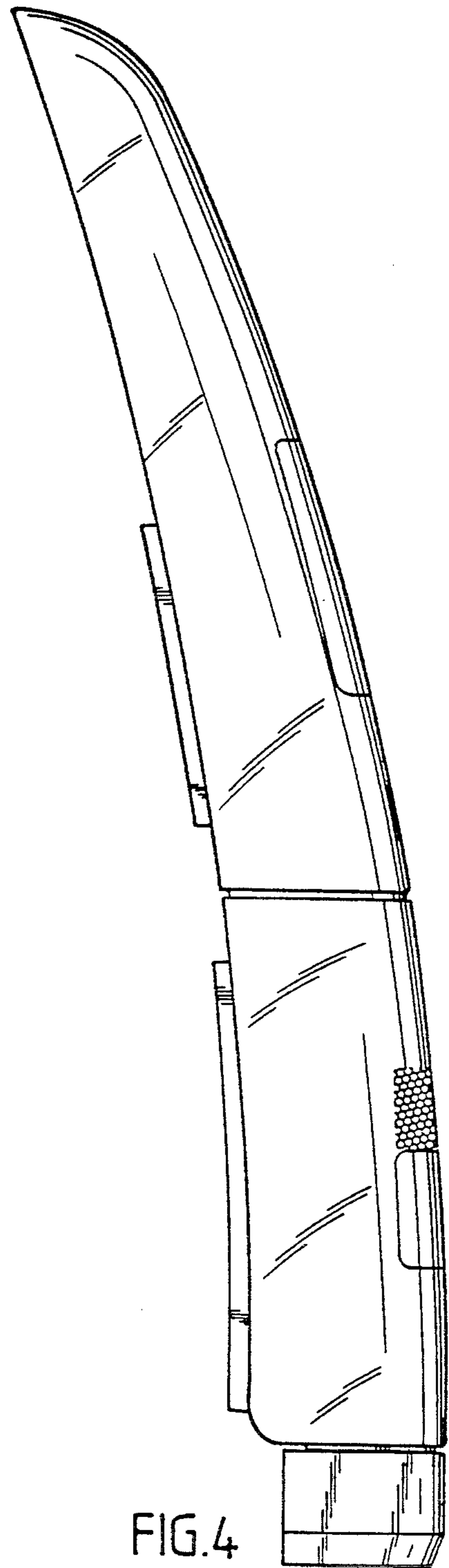

FIG. 4

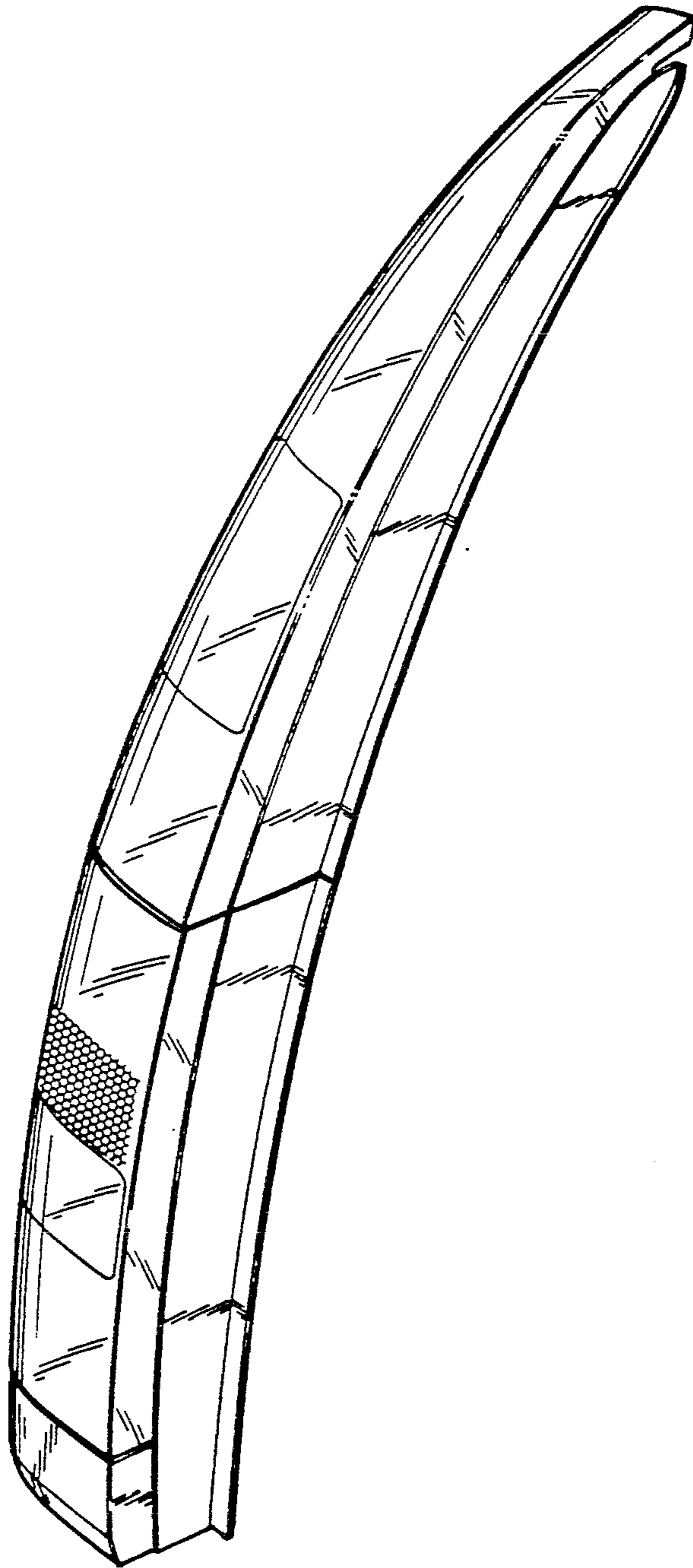

FIG. 5

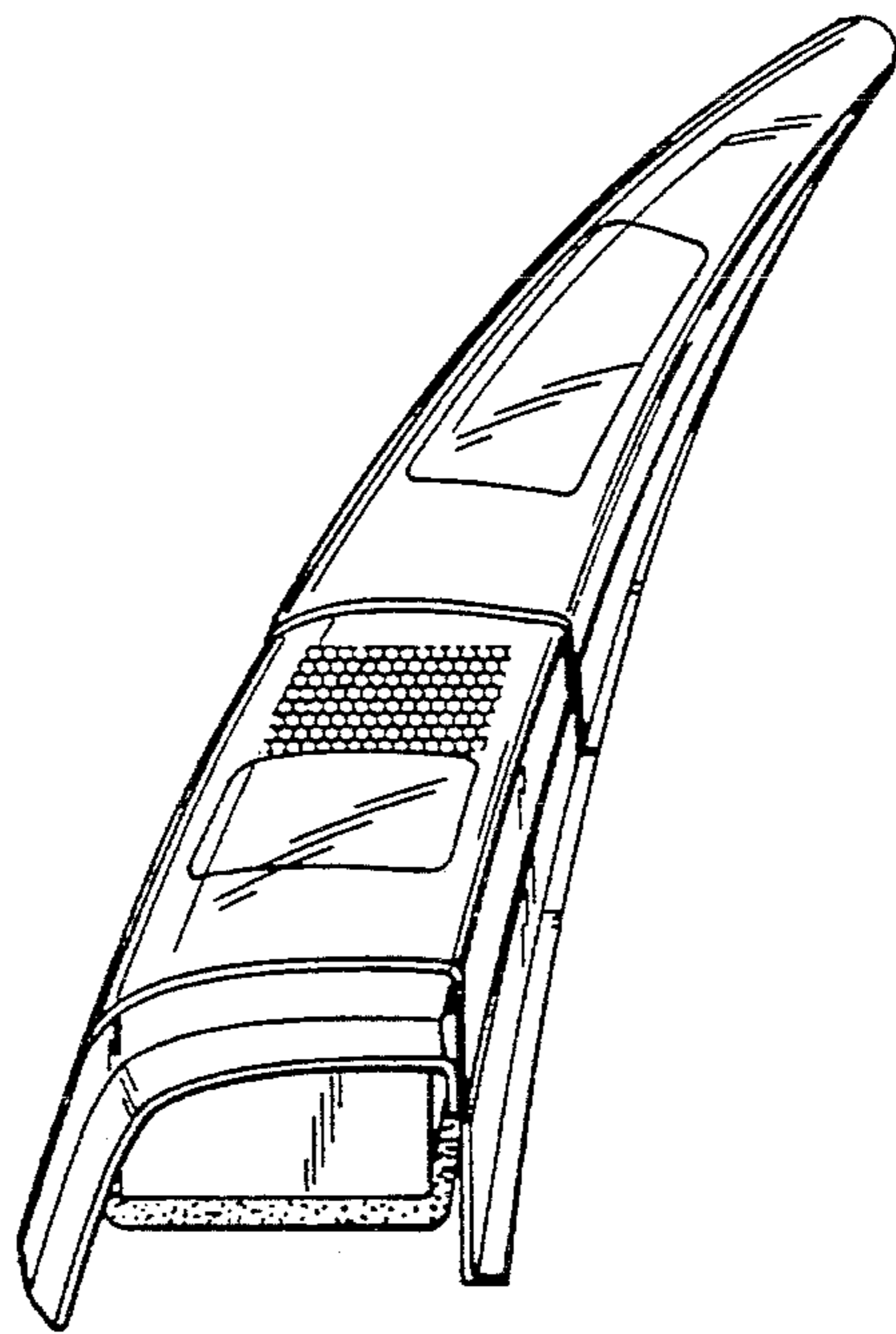

FIG. 6