

[54] MOTORCYCLE

[75] Inventors: **Karl-Heinz Abe**, Steinebach; **Klaus V. Gevert**, Munich, both of Fed. Rep. of Germany

[73] Assignee: **Bayerische Motoren Werke AG**, Fed. Rep. of Germany

[**] Term: **14 Years**

[21] Appl. No.: **316,686**

[22] Filed: **Feb. 28, 1989**

[30] **Foreign Application Priority Data**

Aug. 31, 1988 [DE] Fed. Rep. of Germany 8801346

[52] U.S. Cl. **D12/110**

[58] Field of Search **D12/110; 180/219**

[56] **References Cited**

U.S. PATENT DOCUMENTS

D. 305,009 12/1989 Kanazawa et al. **D12/110**

4,685,530 8/1987 Hara **D12/110**

4,776,422 10/1988 Sakuma **180/219**

OTHER PUBLICATIONS

Cycle World, Dec. 1988, p. 48, BMW K1 Motorcycle.
Cycle World, Dec. 1987, p. 35, Yamaha FZR Motorcycle.

Primary Examiner—James M. Gandy
Assistant Examiner—Melody Brown
Attorney, Agent, or Firm—Evenson, Wands, Edwards,
Lenahan & McKeown

[57] **CLAIM**

The ornamental design for a motorcycle, as shown.

DESCRIPTION

FIG. 1 is a front end perspective view of a motorcycle showing our new design;
FIG. 2 is a rear end perspective view thereof;
FIG. 3 is a right side perspective view thereof;
FIG. 4 is a left side perspective view thereof;
FIG. 5 is a top perspective view thereof;
FIG. 6 is a left side perspective view taken from the front thereof;
FIG. 7 is a right side perspective view taken from the rear thereof.

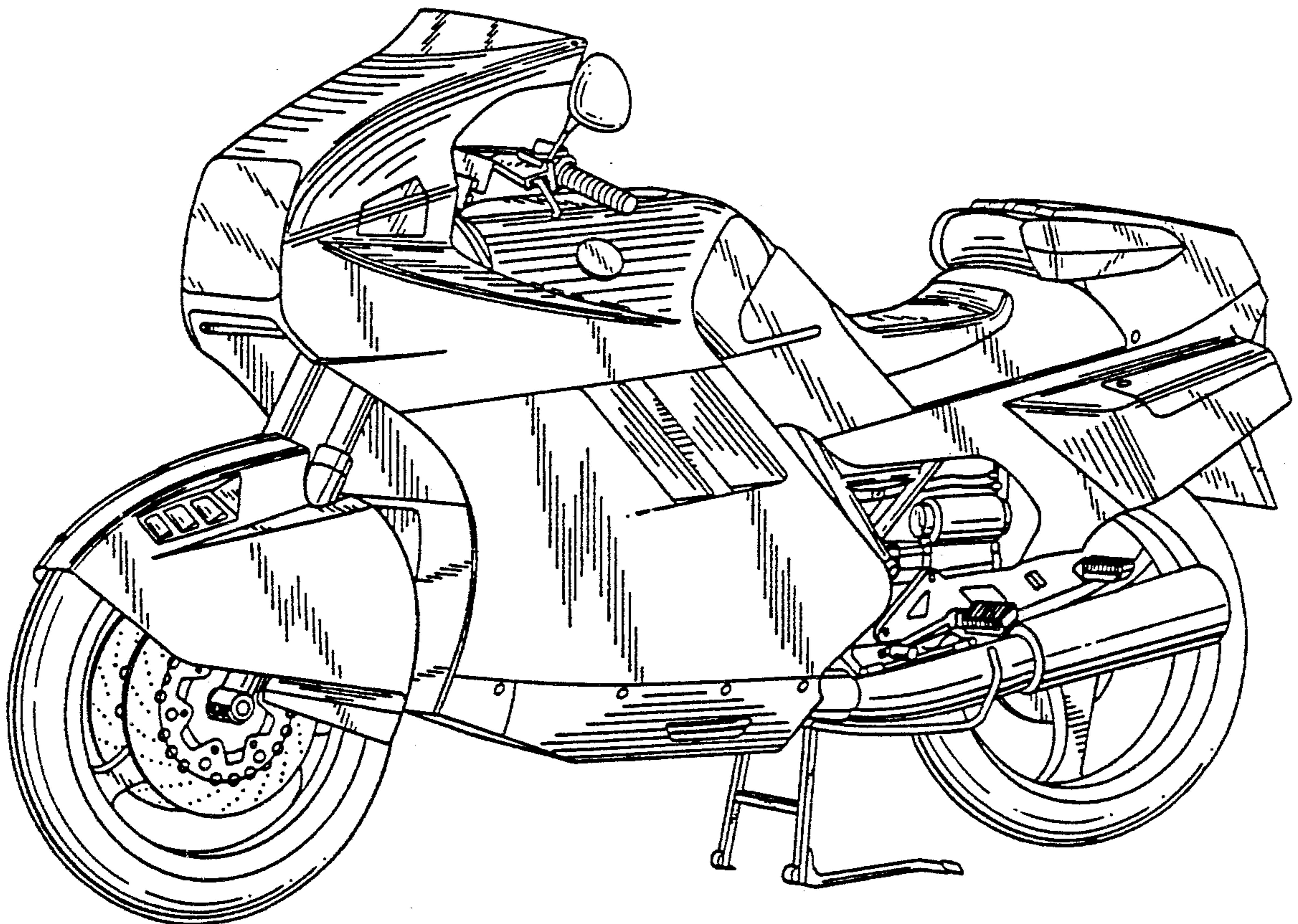

FIG. 2

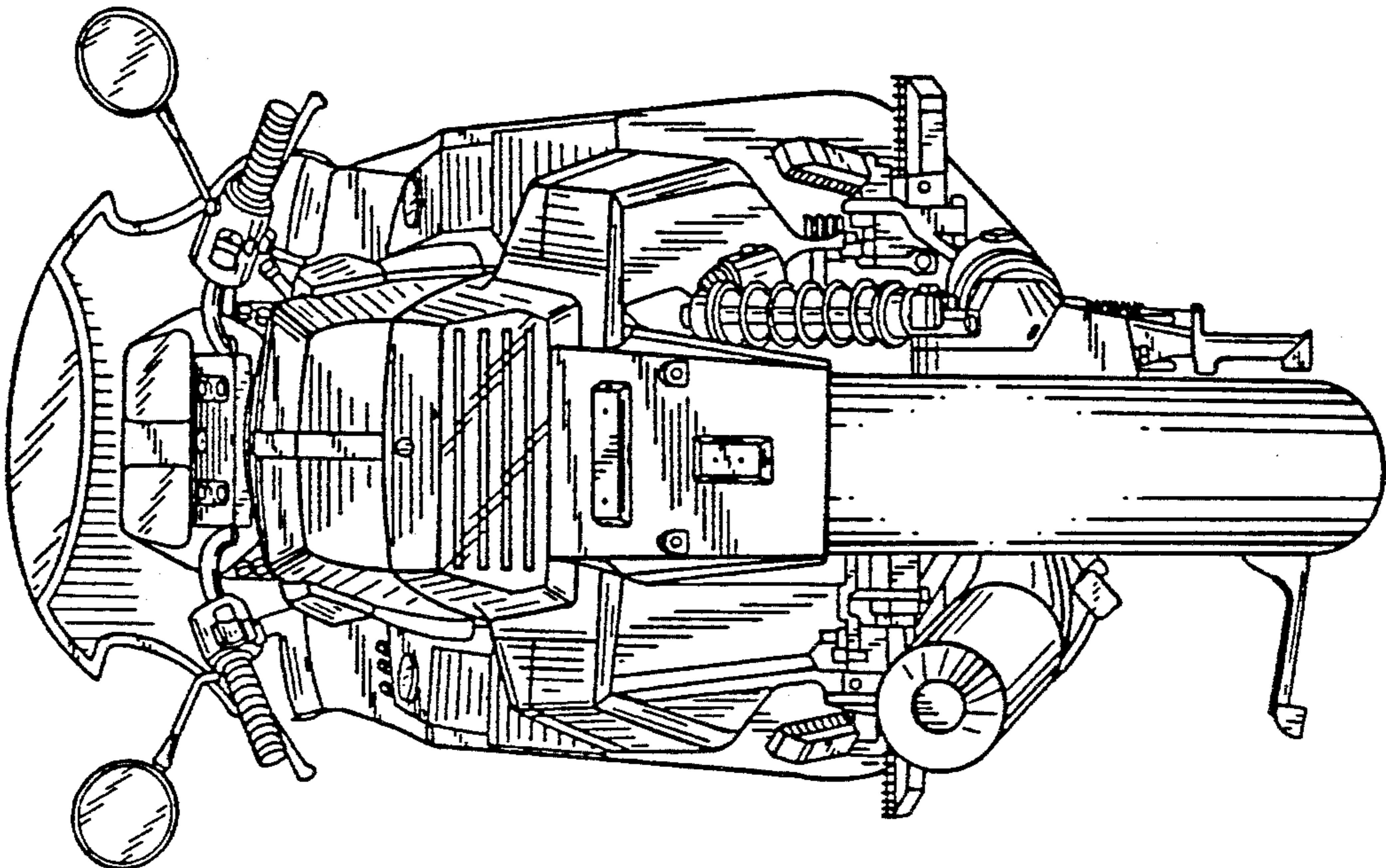

FIG. 1

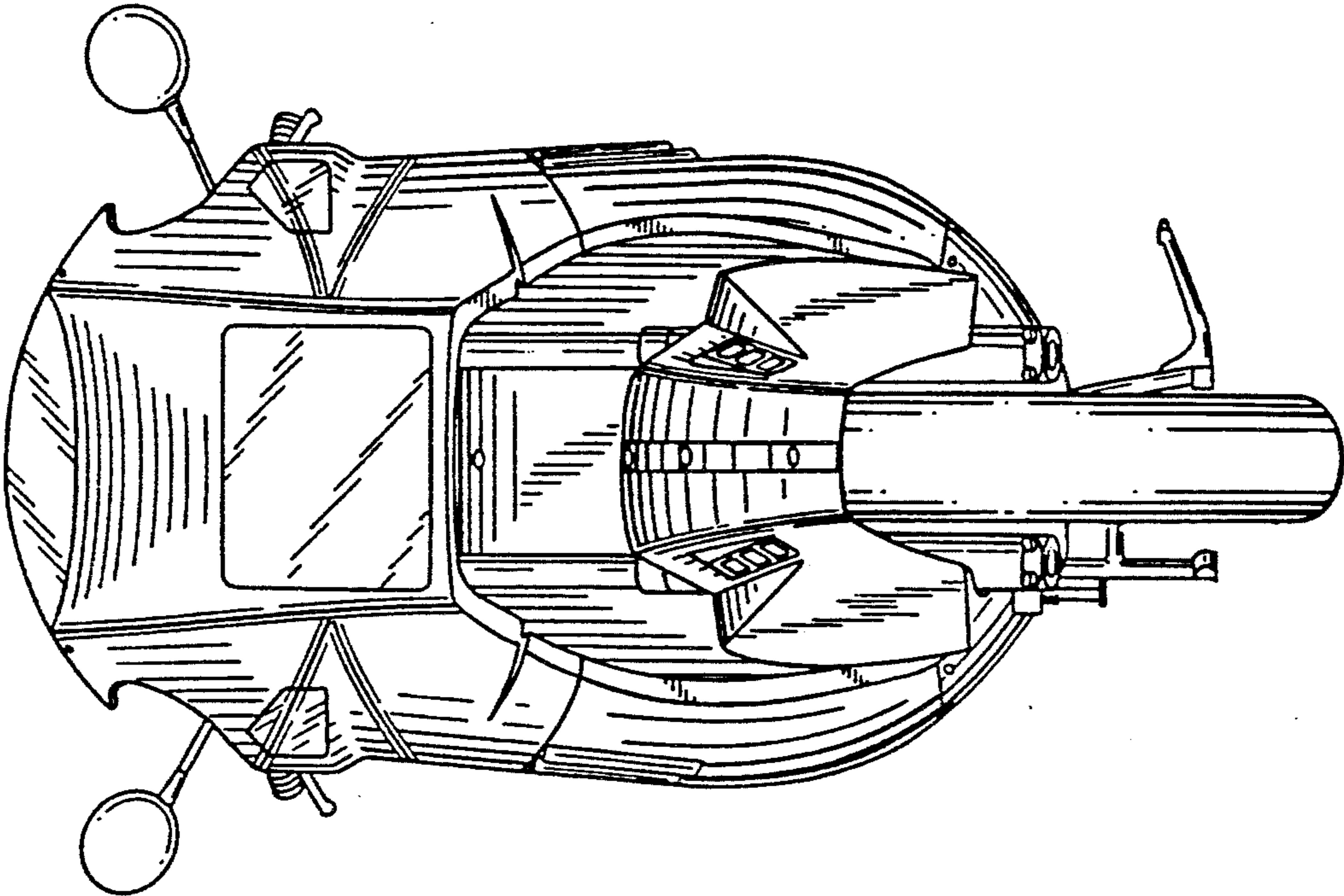

FIG. 3

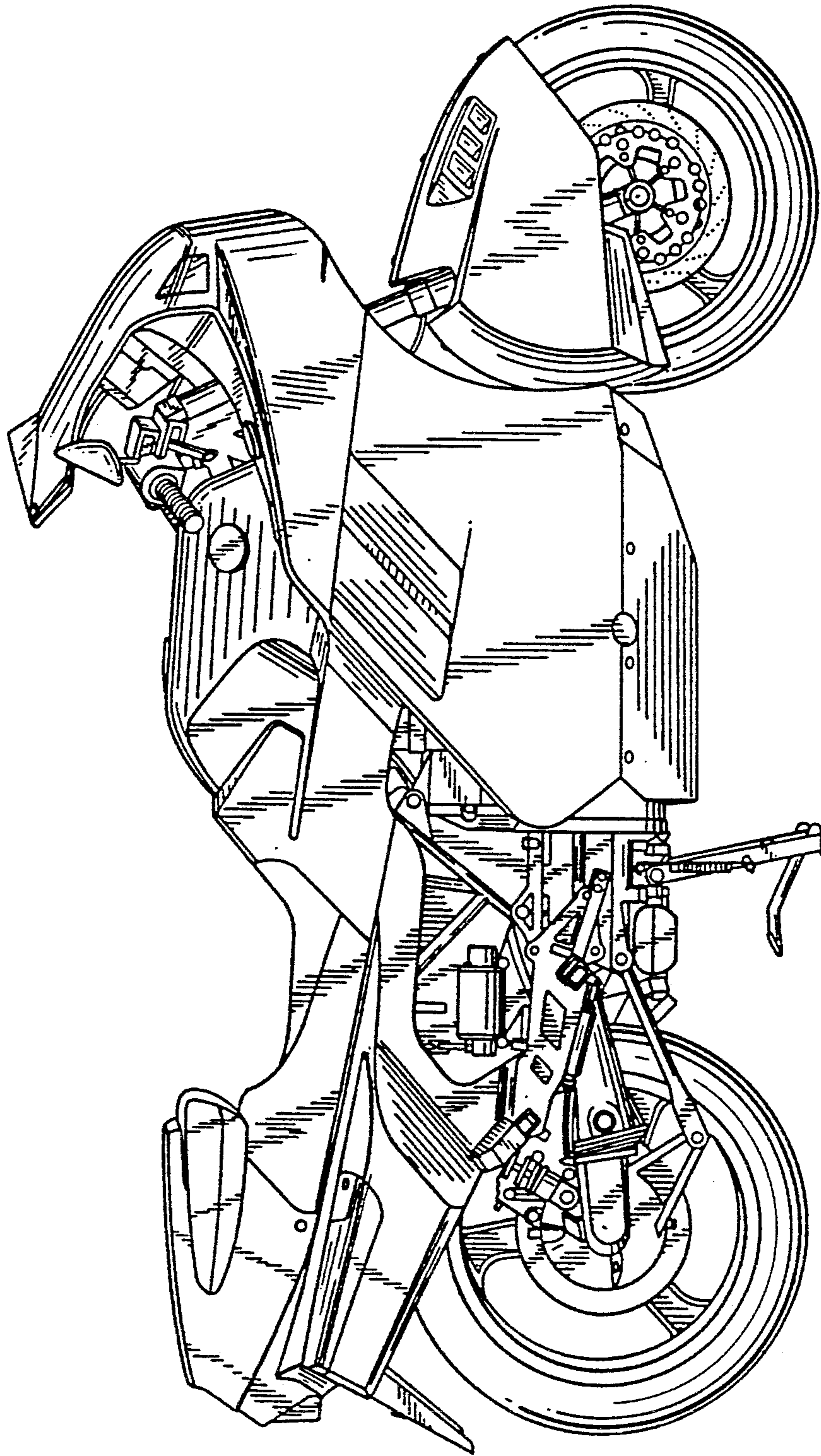

FIG. 4

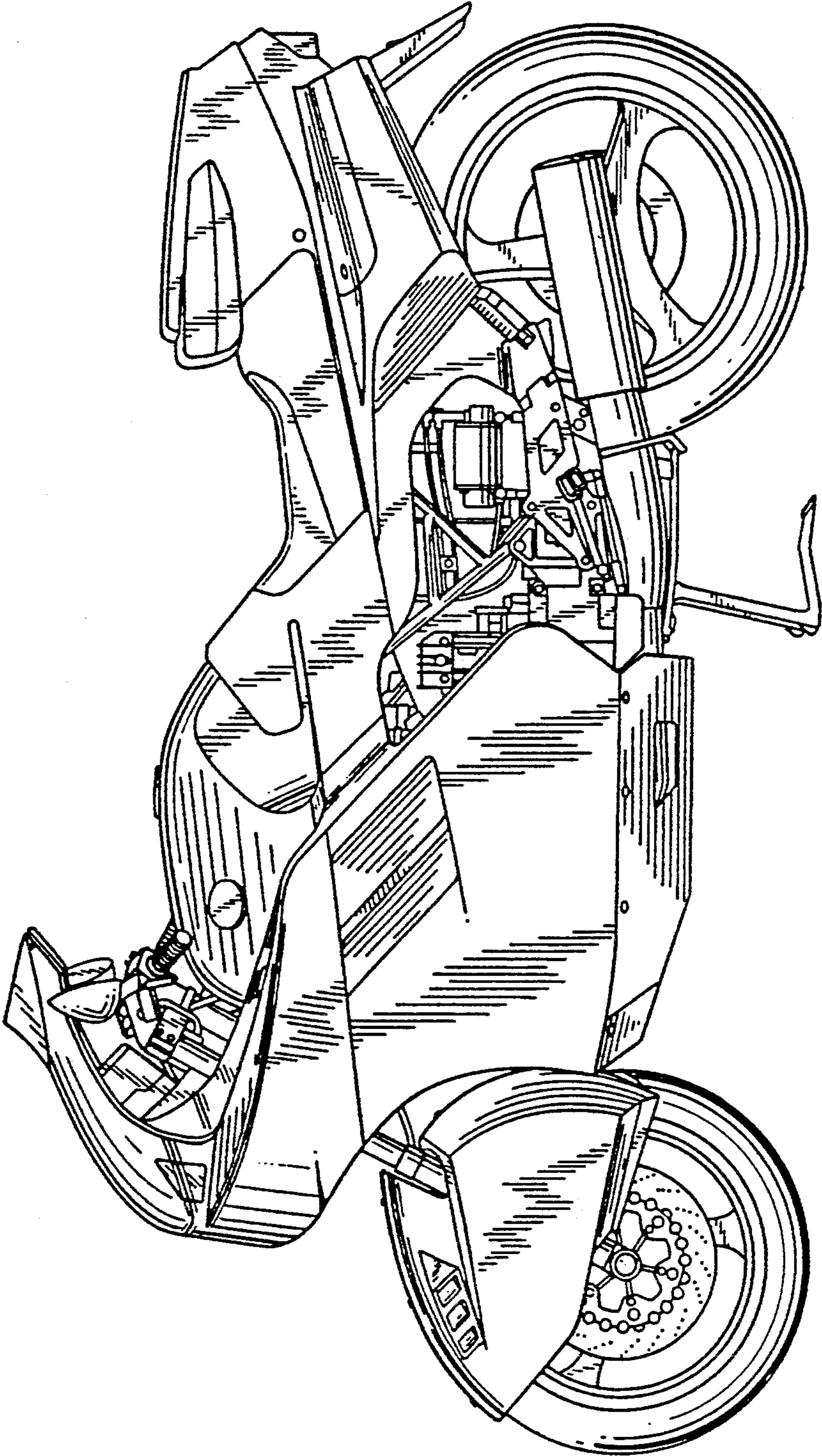

FIG. 5

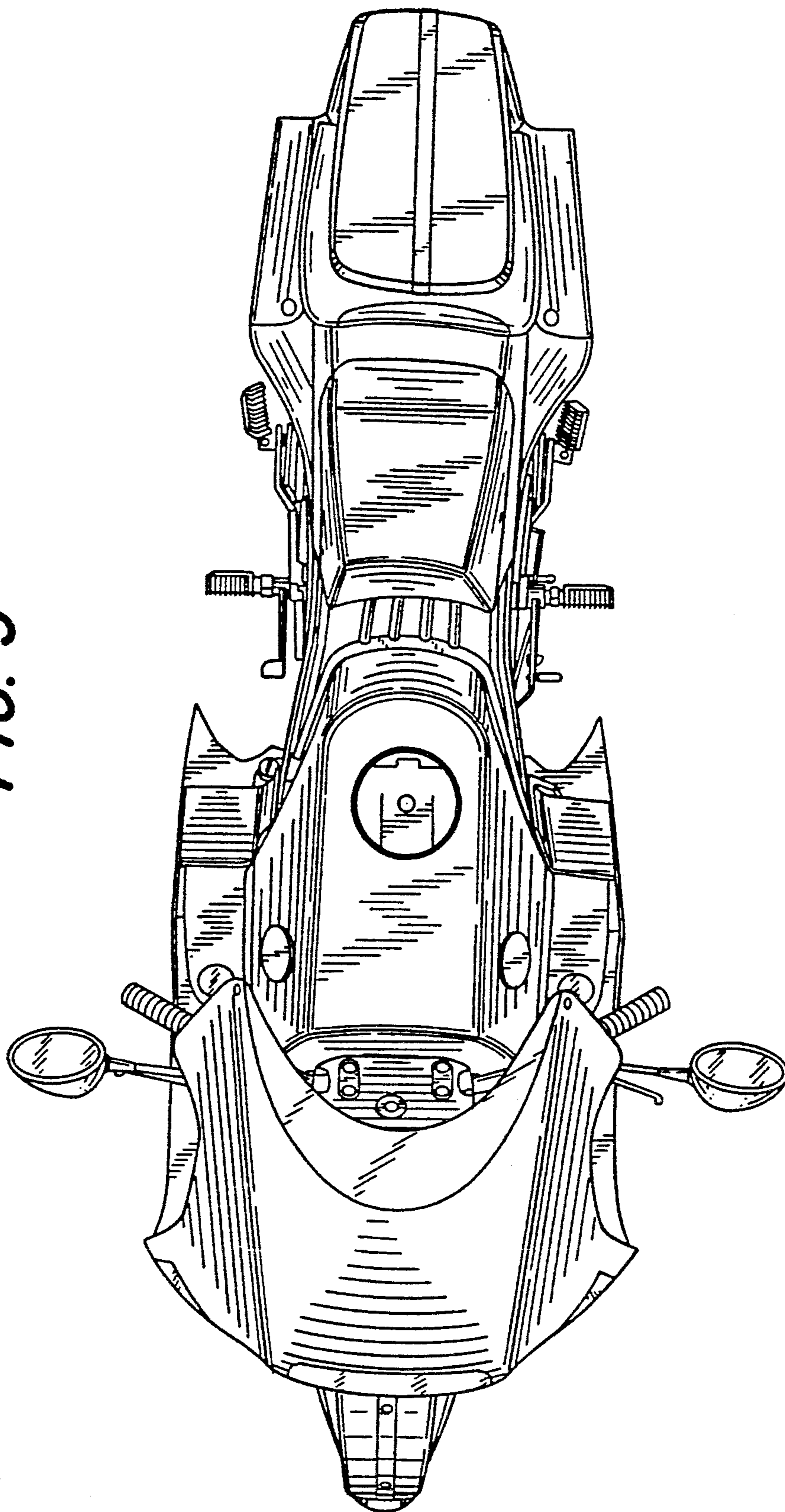

FIG. 6

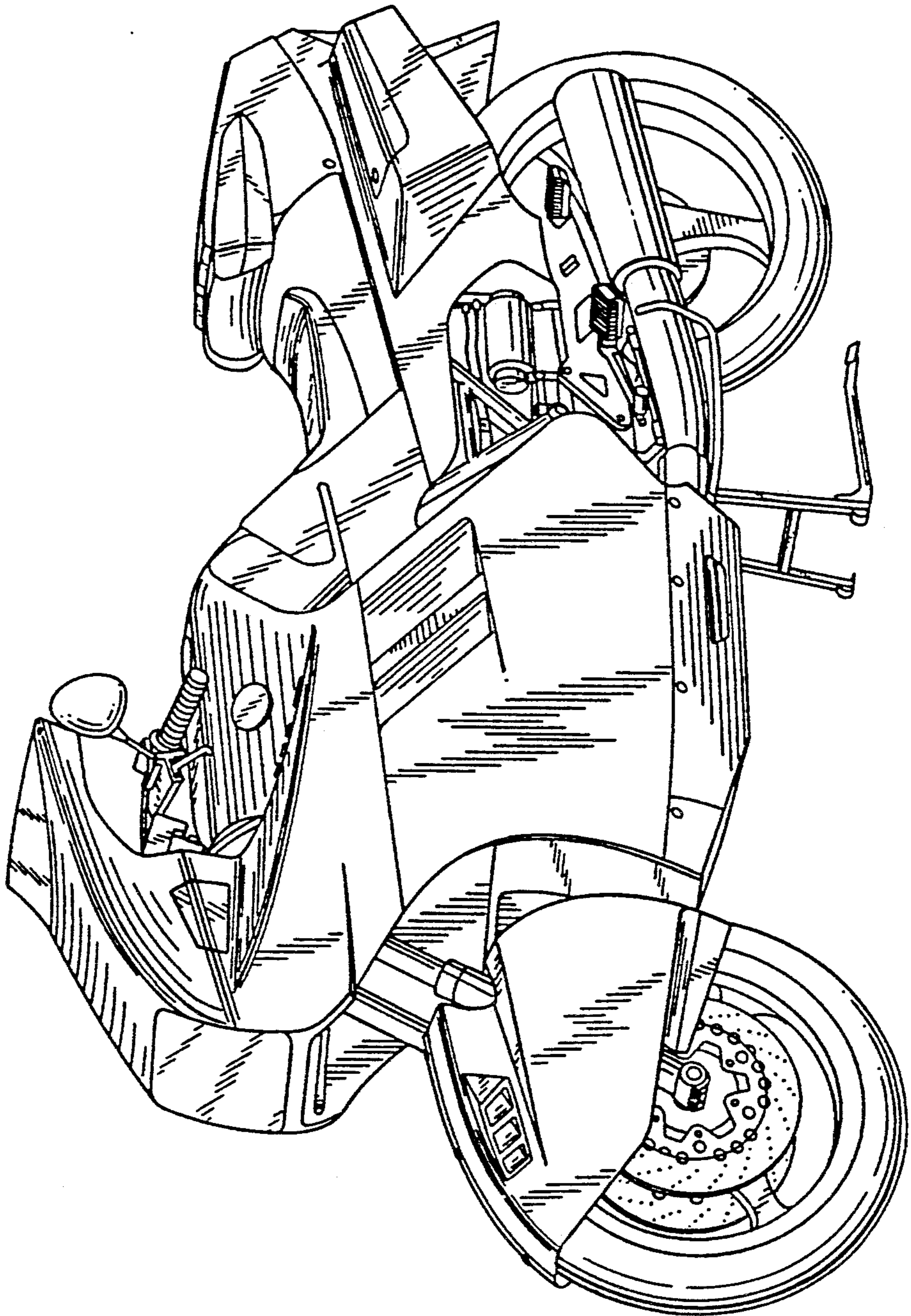

FIG. 7

