

[54] POWERED INVALID VEHICLE

[56] References Cited

U.S. PATENT DOCUMENTS

[76] Inventors: Wendell G. Blount, P.O. Box 1032, Calhoun City, Miss. 38916; Ronald J. Mosekich, Rte. II, Box 35, Koscisko, Miss. 39090; Bedford F. Peeples, 1609 Deering St., Cleveland, Miss. 38732

D. 303,101	8/1989	Shepard et al.	D12/131
4,570,739	2/1986	Kramer	180/907
4,729,447	3/1988	Morse	180/907
4,947,955	8/1990	Hopely, Jr.	180/907

Primary Examiner—Kay H. Chin
Attorney, Agent, or Firm—Dowell & Dowell

[**] Term: 14 Years

[57] CLAIM

The ornamental design for a powered invalid vehicle, as shown and described.

[21] Appl. No.: 483,005

DESCRIPTION

[22] Filed: Feb. 22, 1990

[52] U.S. Cl. D12/131; D12/128

[58] Field of Search D12/131, 128; 280/250.1, 647, 642; 180/907, 65 R

FIG. 1 is a rear perspective views of a powered invalid vehicle showing our new design;
FIG. 2 is a front elevational view thereof;
FIG. 3 is a left side elevational view thereof.
FIG. 4 is a right side elevational view thereof.
The undisclosed bottom is flat and unornamented.

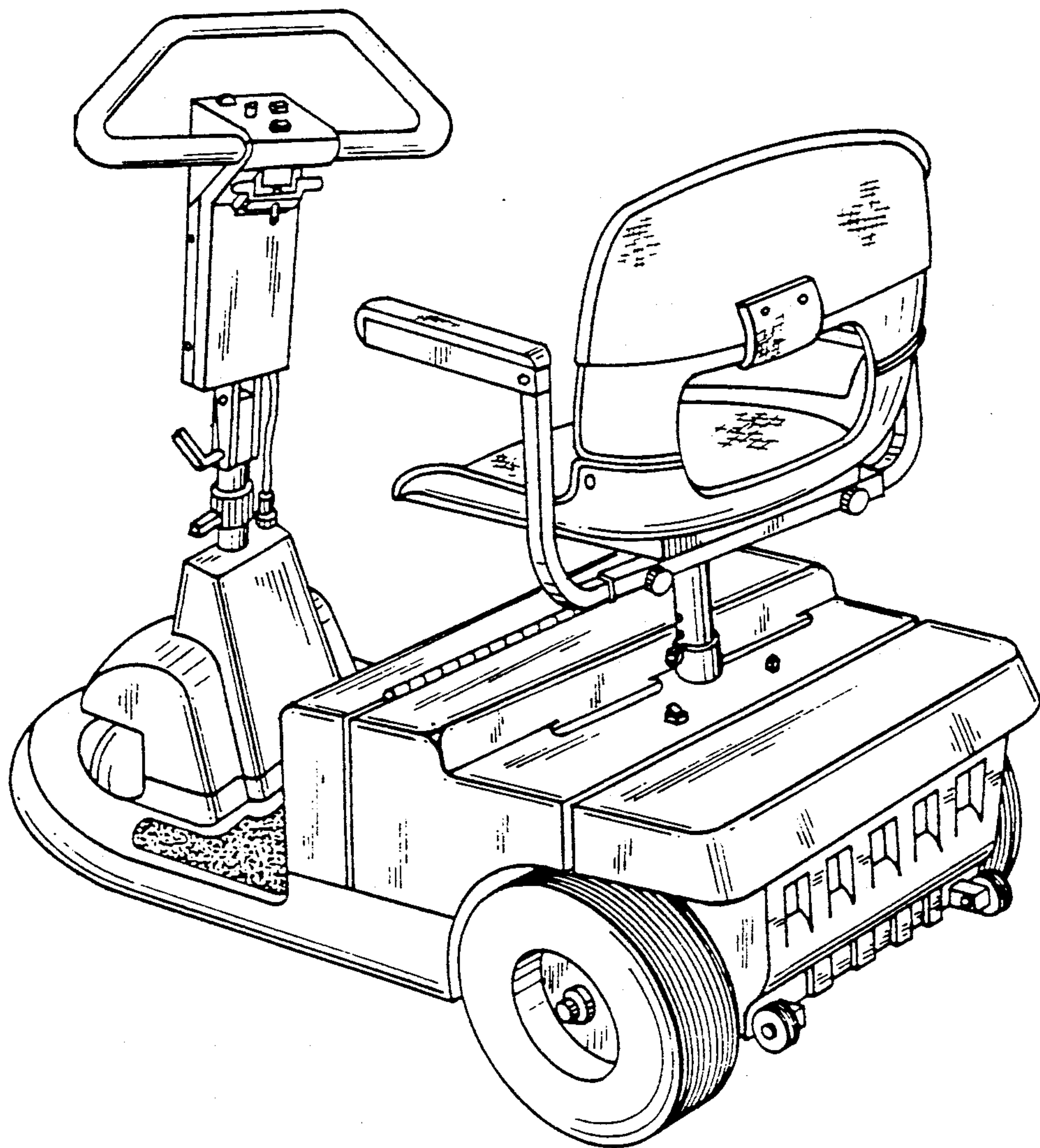

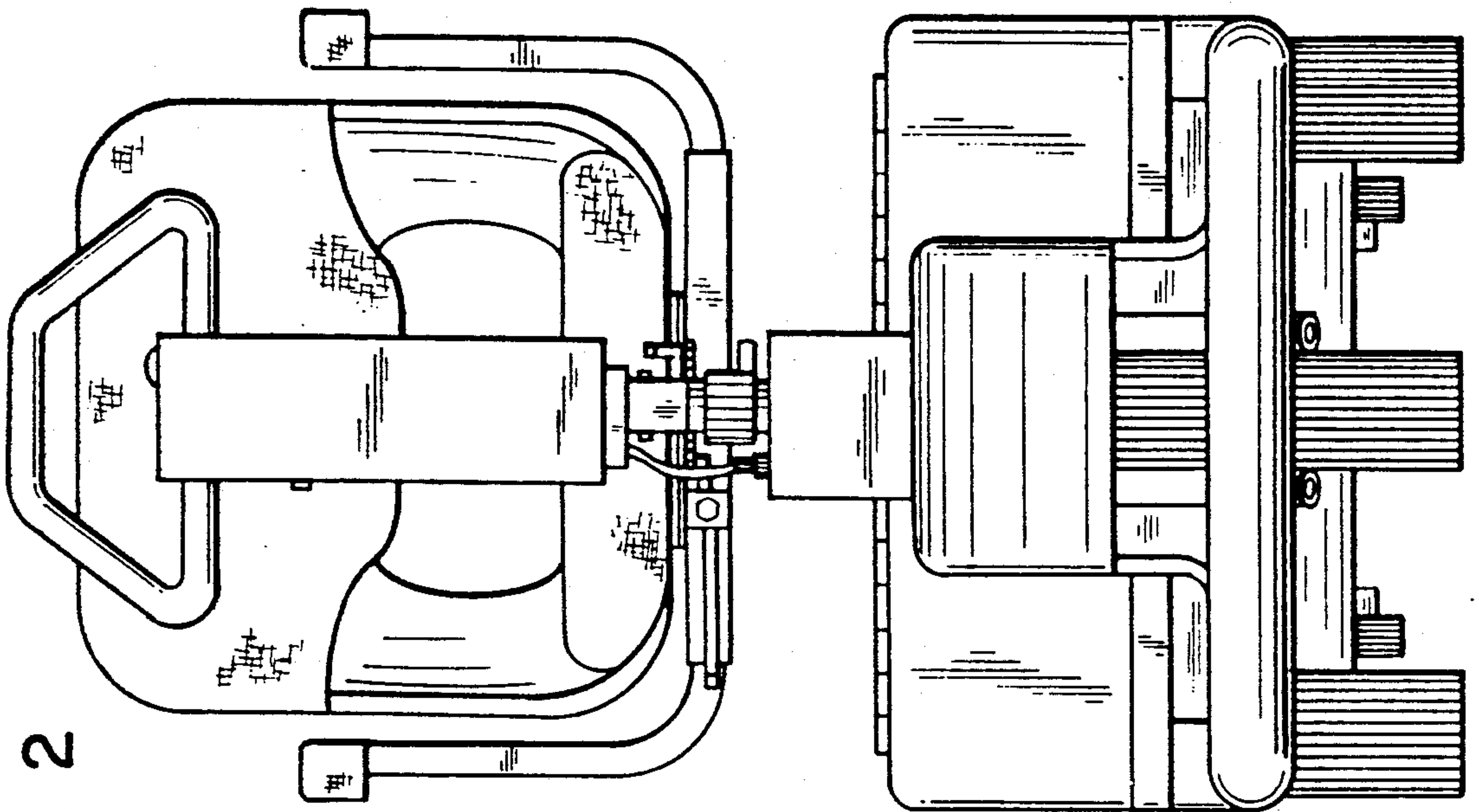

FIG. 2

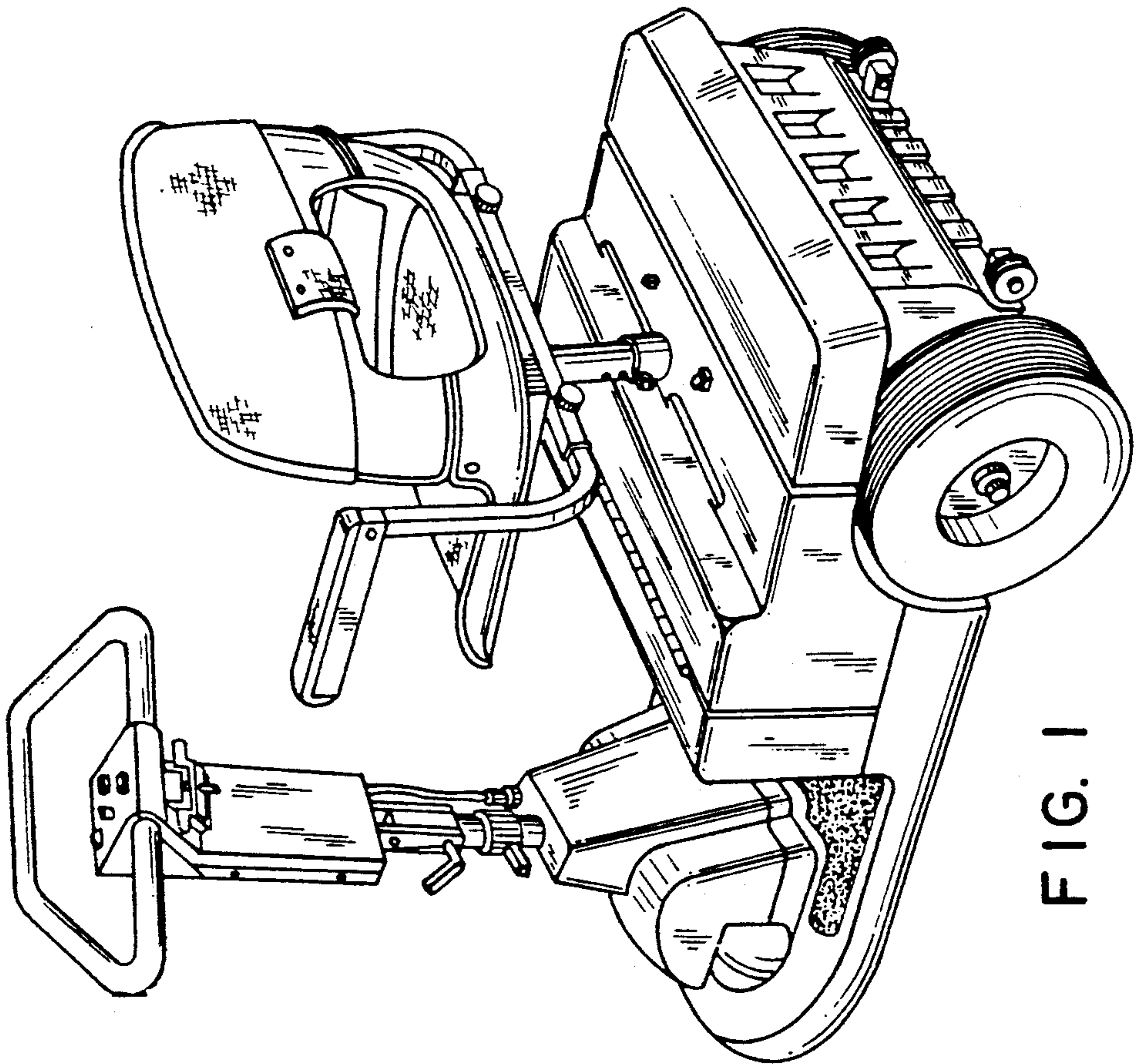

FIG. 1

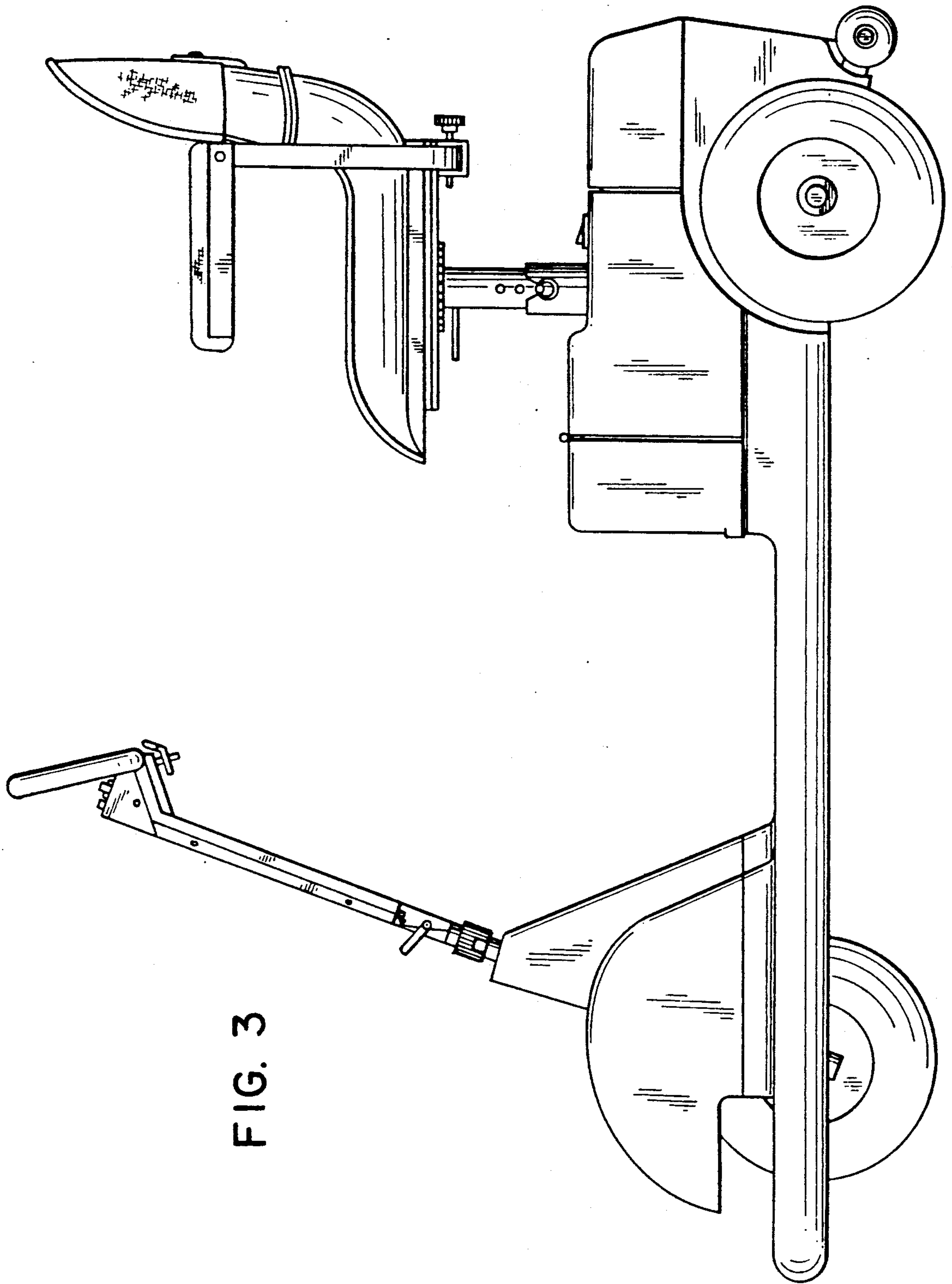

FIG. 3

FIG. 4

