

[54] FENDER RECEPTACLE UNIT FOR A FOUR WHEEL VEHICLE

4,749,205 6/1988 Takahashi et al. .... 280/282  
4,907,428 3/1990 Nakashima ..... 180/219

[75] Inventors: Kazuhiko Saito, Rancho Palos Verdes; Yutaka Kawasaki, Redondo Beach, both of Calif.

[73] Assignee: Honda Giken Kogyo Kabushiki Kaisha, Tokyo, Japan

[\*\*] Term: 14 Years

[21] Appl. No.: 337,124

[22] Filed: Apr. 12, 1989

[52] U.S. Cl. .... D12/117; D12/158

[58] Field of Search ..... D12/117, 112, 107, 158; 180/219, 215; 224/32 R, 32 A

[56] References Cited

U.S. PATENT DOCUMENTS

D. 244,927	7/1977	Anthon, III	.....	D12/158
D. 289,986	5/1987	Ooba et al.	.....	D12/107
D. 293,900	1/1988	Murakami	.....	D12/107
D. 305,999	2/1990	Ueda et al.	.....	D12/107
4,667,758	5/1987	Tamura	.....	180/68.4
4,687,069	8/1987	Inomata et al.	.....	180/68.2
4,730,838	3/1988	Takashashi	.....	280/6 R

OTHER PUBLICATIONS

Cycle World, Dec. 1988, p. 53, The Kawasaki 220 Bayou, and Bayou 4x4 four wheel vehicles.

Primary Examiner—James M. Gandy  
Assistant Examiner—Melody Brown  
Attorney, Agent, or Firm—Irving M. Weiner; Joseph P. Carrier; Pamela S. Burt

[57] CLAIM

The ornamental design for a fender receptacle unit for a four wheel vehicle, as shown and described.

DESCRIPTION

FIG. 1 is a left side elevational view of a fender receptacle unit for a four wheel vehicle showing our new design, it being understood that the broken lines are for illustrative purposes only and form no part of the claimed design.

FIG. 2 is a top plan view thereof.

FIG. 3 is a left side elevational view thereof.

FIG. 4 is a rear elevational view thereof.

FIG. 5 is a front elevational view thereof.

FIG. 6 is a bottom plan view thereof.

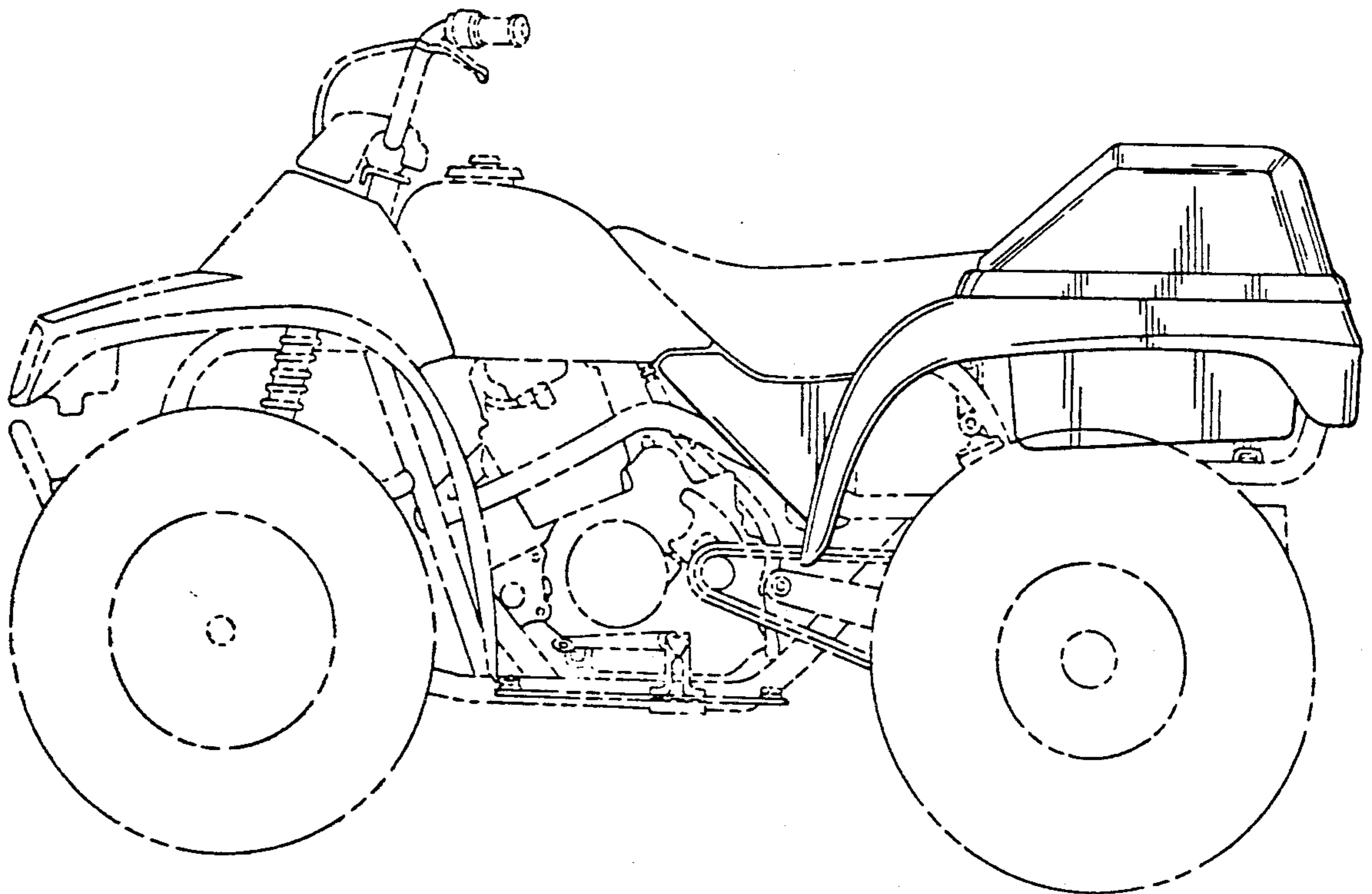

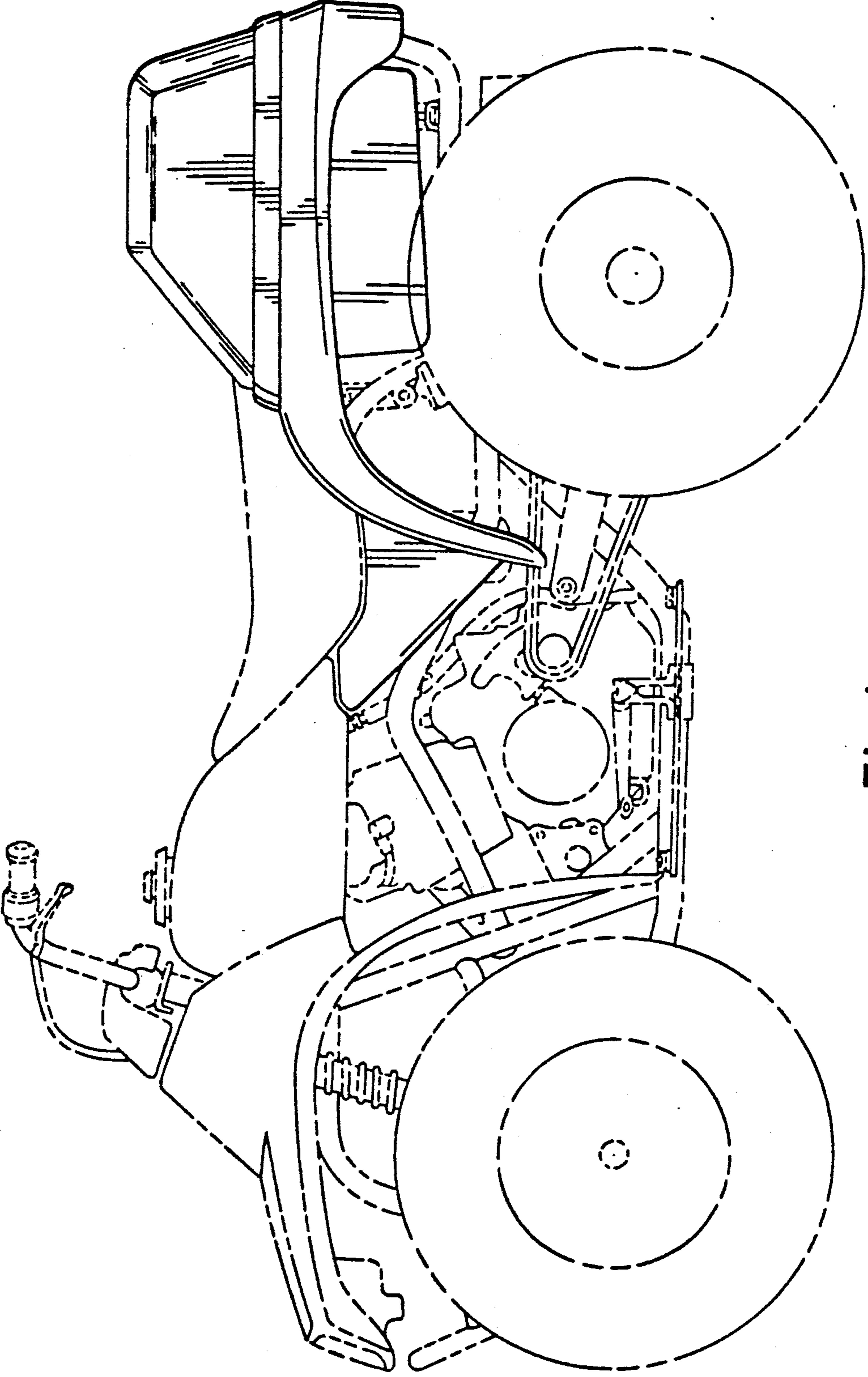

Fig. 1

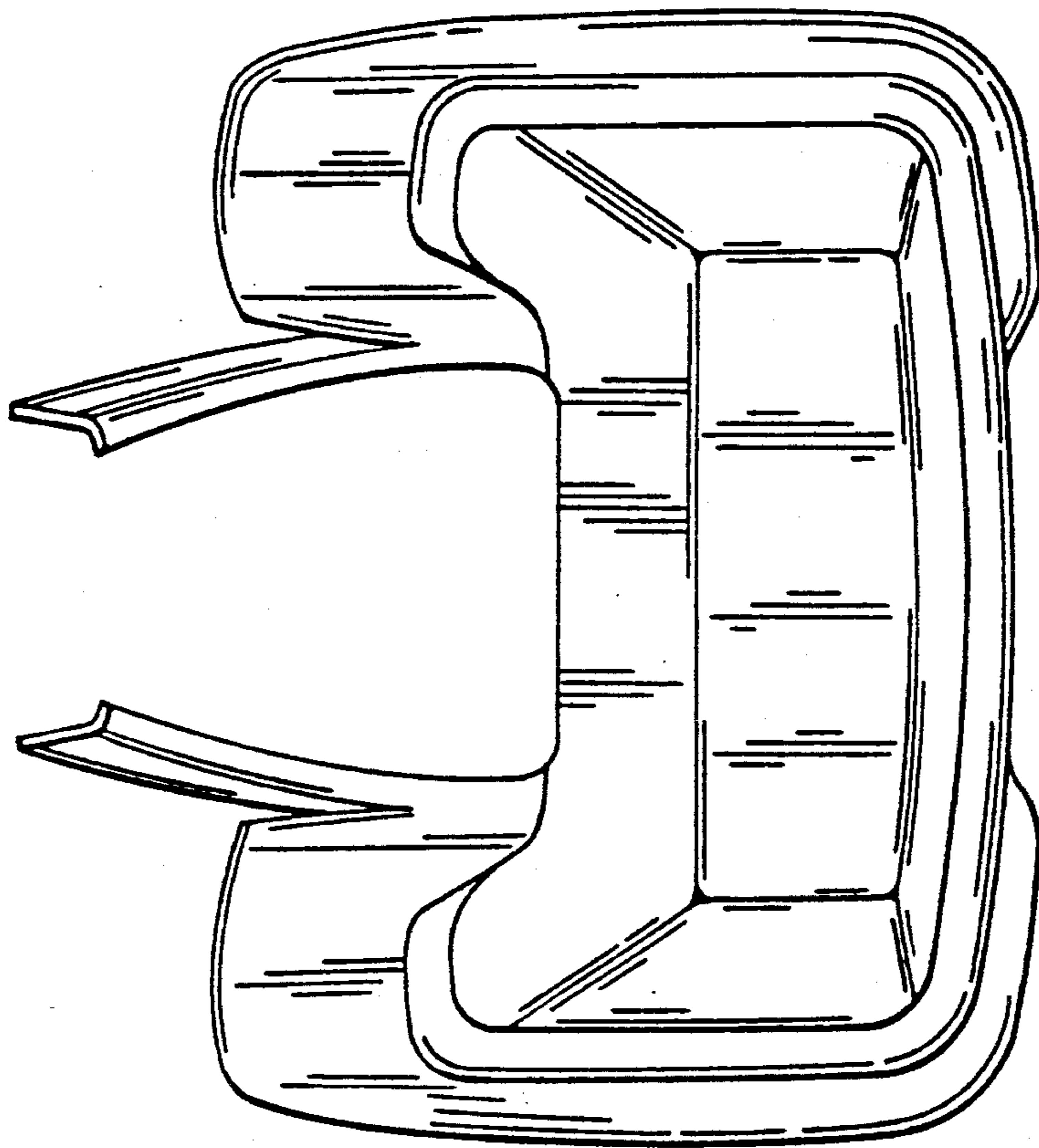

Fig. 2

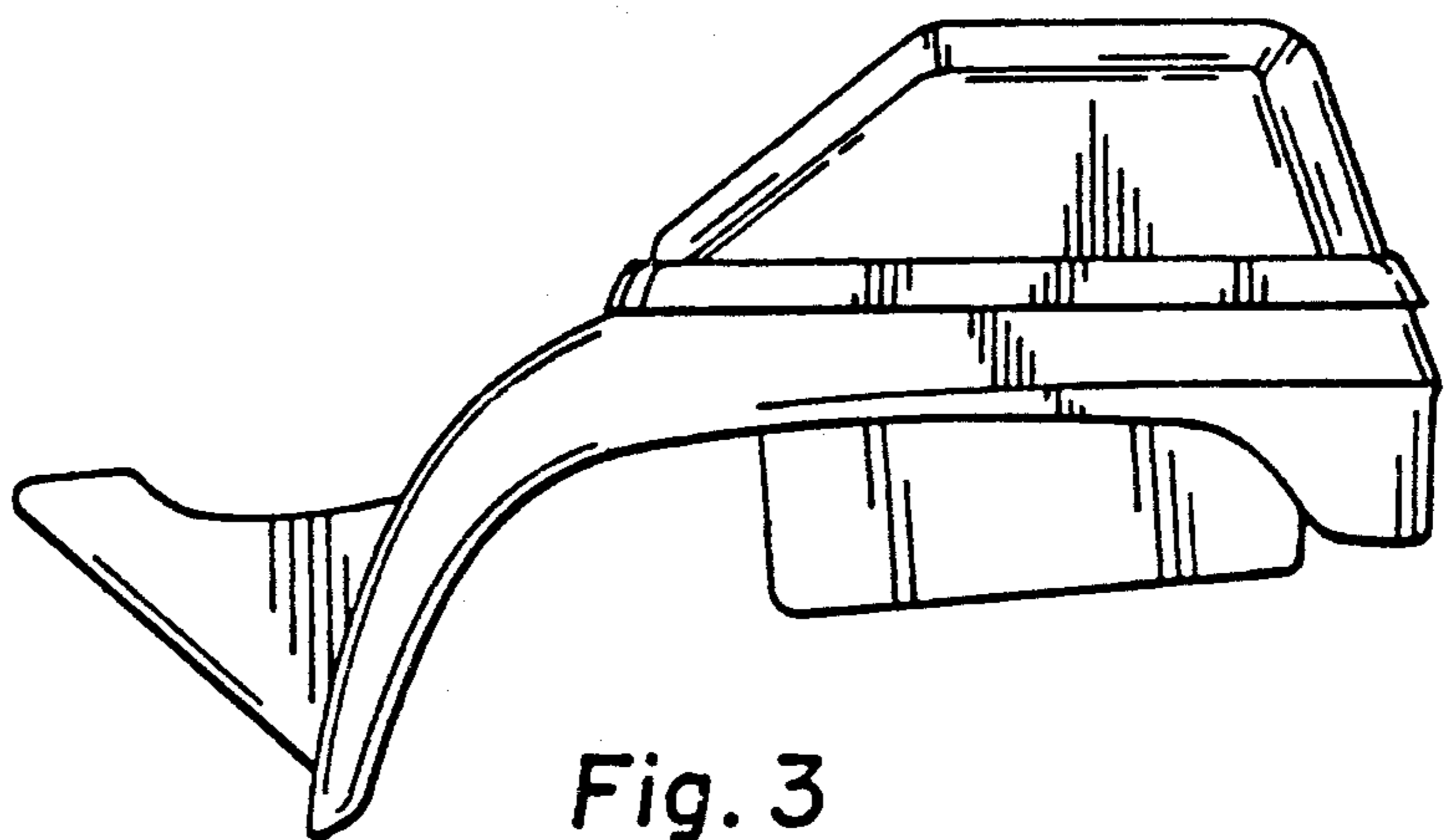

Fig. 3

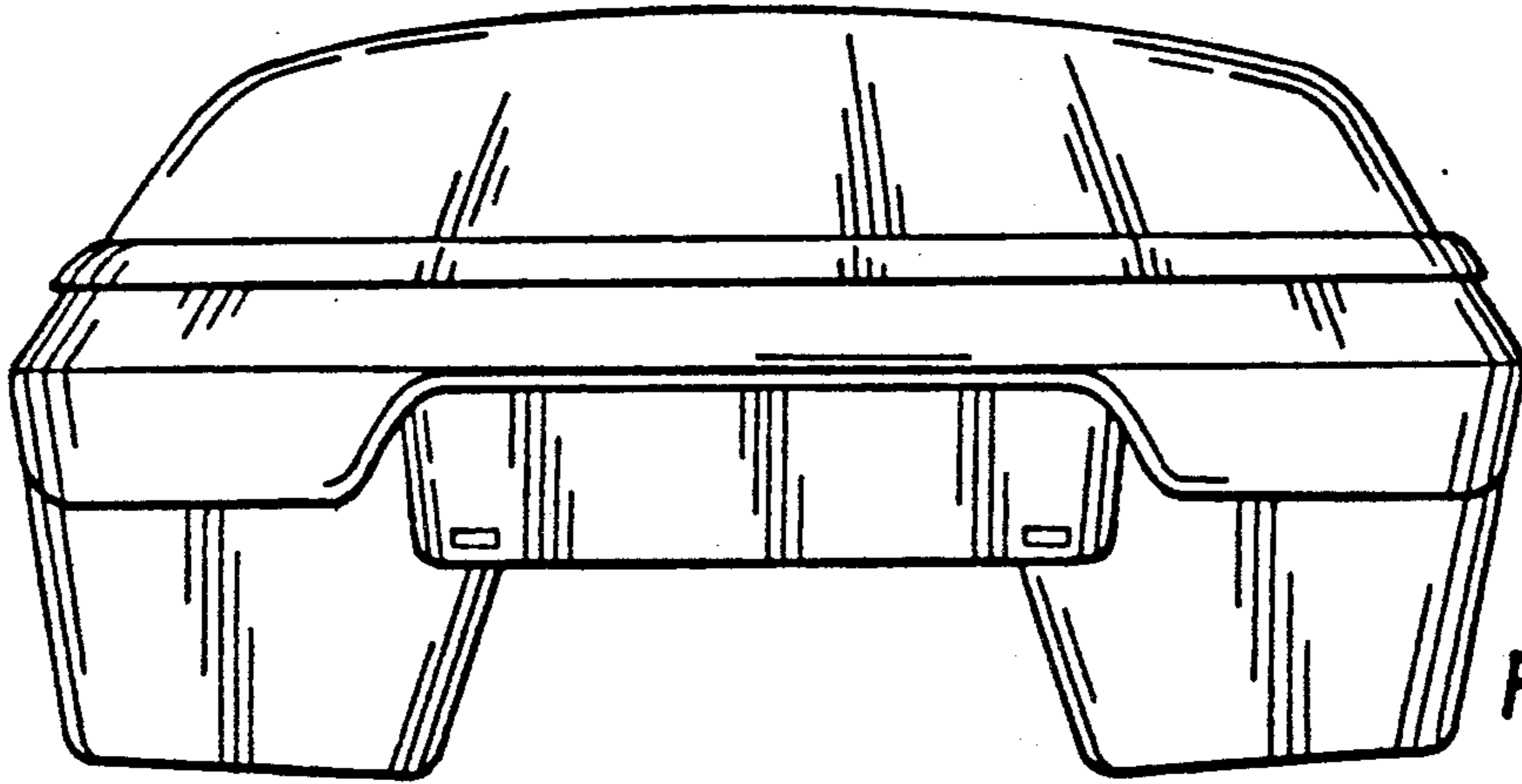

Fig. 4

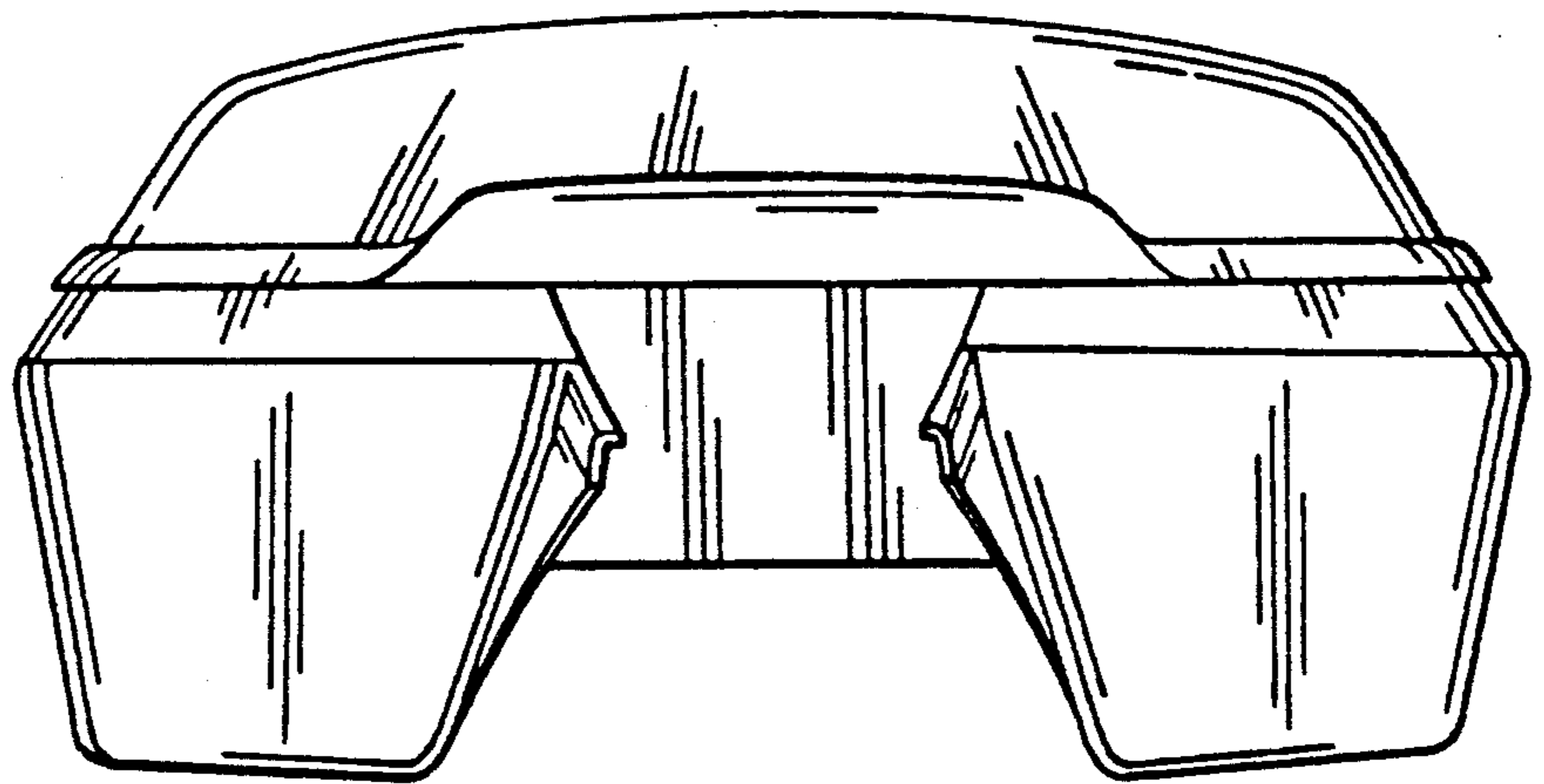

Fig. 5

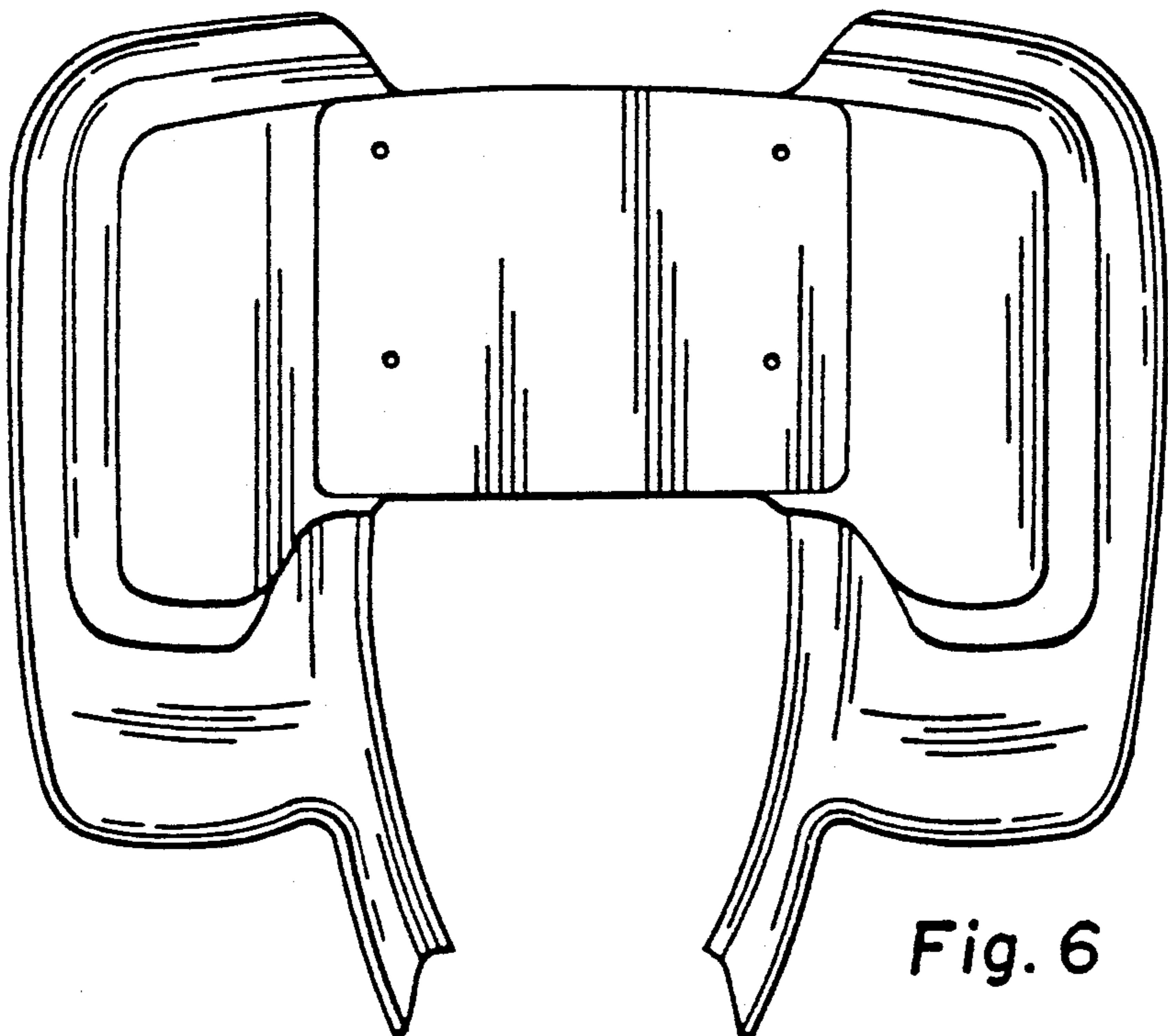

Fig. 6