

[54] MOTORCYCLE

[75] Inventors: Makoto Kitagawa, Shiki; Toshio Kurihara, Tokorozawa; Elizi Ozawa, Asaka, all of Japan

[73] Assignee: Honda Giken Kogyo Kabushiki Kaisha, Tokyo, Japan

[**] Term: 14 Years

[21] Appl. No.: 322,822

[22] Filed: Mar. 13, 1989

[30] Foreign Application Priority Data

Sep. 13, 1988 [JP] Japan 63-36166

Dec. 28, 1988 [JP] Japan 63-51560

[52] U.S. Cl. D12/110

[58] Field of Search D12/110; 180/219

[56] References Cited

U.S. PATENT DOCUMENTS

4,762,197 8/1988 Yamada et al. D12/110

OTHER PUBLICATIONS

Cycle World, Apr. 1988, pp. 102 & 103, The R100RT BMW Motorcycle.

Cycle World, Jul. 1987, pp. 50 & 51, The K100LT BMW Motorcycle.

Cycle World, vol. 27, No. 9, Sep. 1988, pp. 33-35.

Cycle World Buyer's Guide 1989, pp. 79-85.

Cycle World Buyer's Guide 1989, pp. 78-119.

Primary Examiner—James M. Gandy

Assistant Examiner—Melody Brown

Attorney, Agent, or Firm—Armstrong, Nikaido, Marmelstein, Kubovcik & Murray

[57] CLAIM

The ornamental design for a motorcycle, as shown and described.

DESCRIPTION

FIG. 1 is a left side elevation view of a motorcycle showing our new design;

FIG. 2 is a right side elevation view thereof;

FIG. 3 is a front elevation view thereof;

FIG. 4 is a rear elevation view thereof;

FIG. 5 is a top plan view thereof;

FIG. 6 is a bottom plan view thereof;

FIG. 7 is a left side perspective view thereof;

FIG. 8 is a left side elevation view of a motorcycle showing a second embodiment of our new design;

FIG. 9 is a right side elevation view of a FIG. 8;

FIG. 10 is a front elevation view of FIG. 8;

FIG. 11 is a rear elevation view of FIG. 8;

FIG. 12 is a top plan view of FIG. 8;

FIG. 13 is a bottom plan view of FIG. 8; and

FIG. 14 is a left side perspective view of FIG. 8.

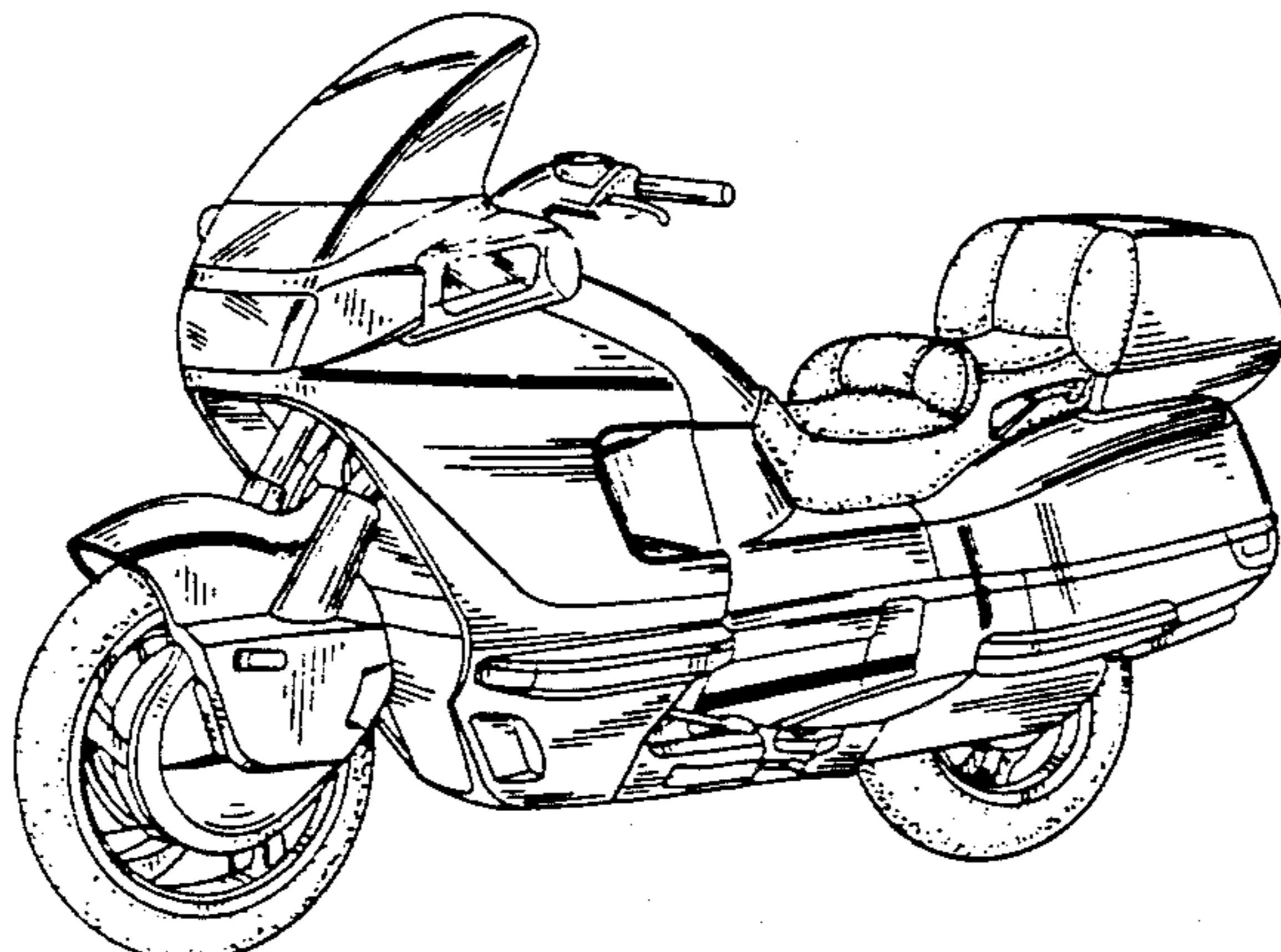
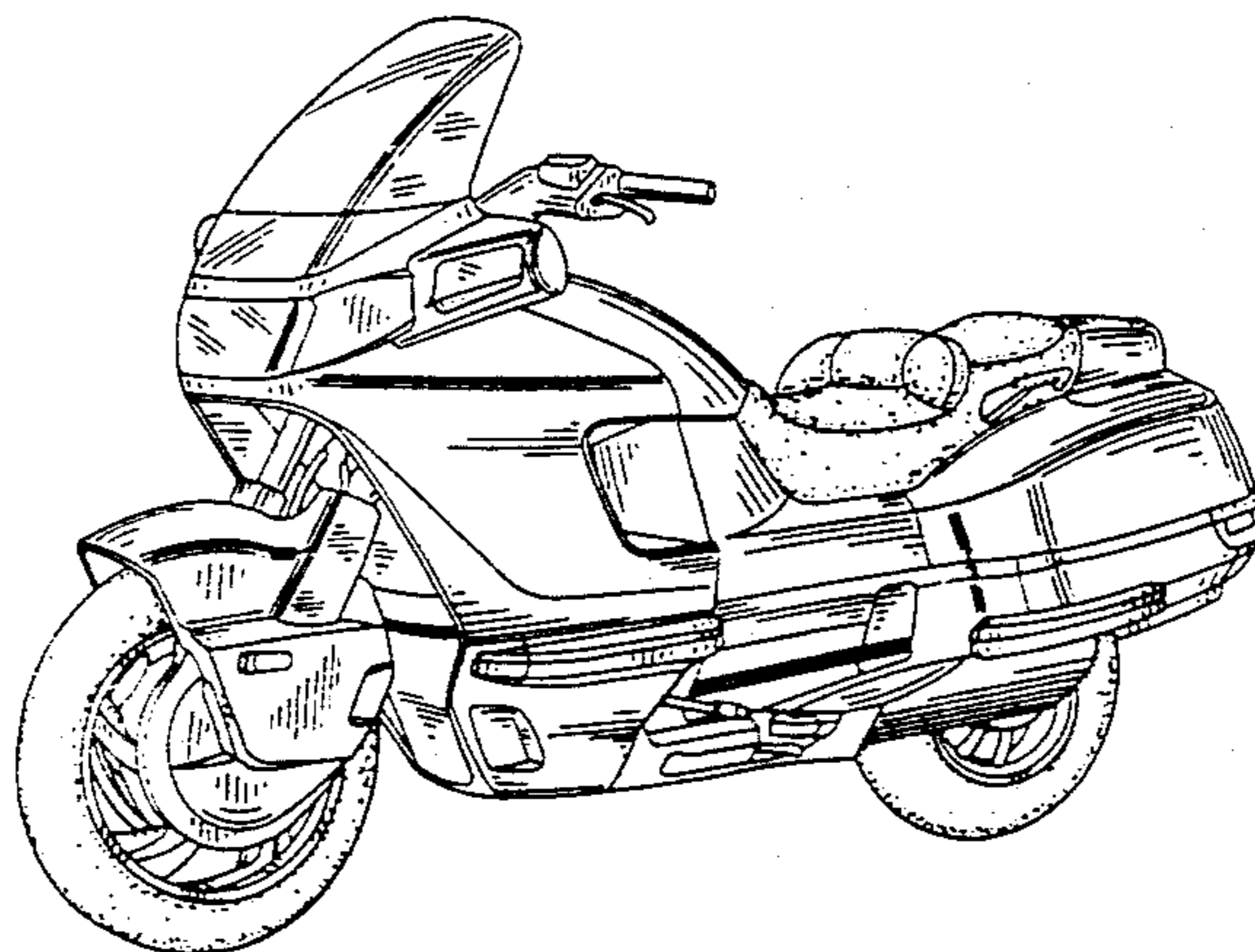

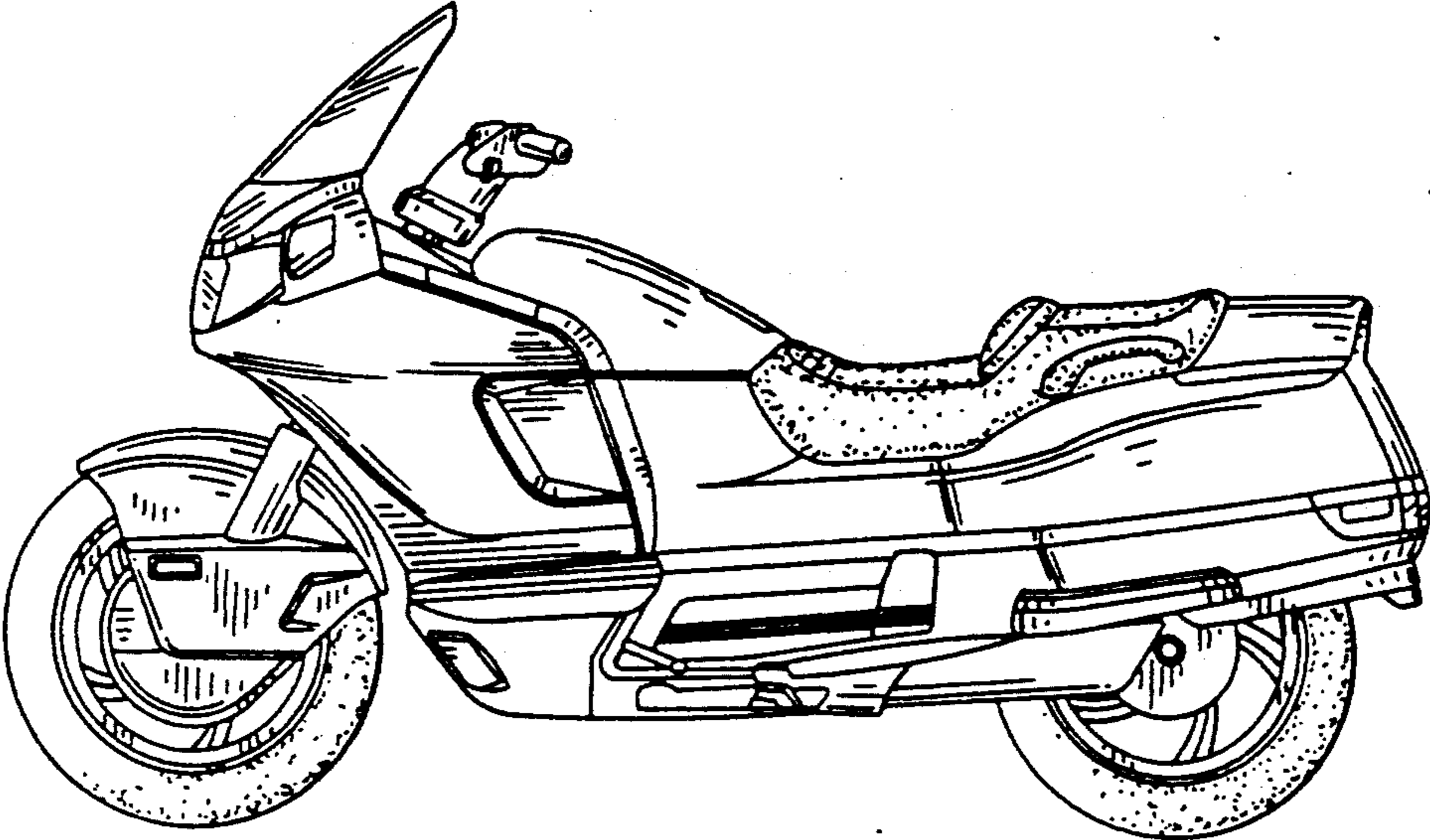

Fig. 1

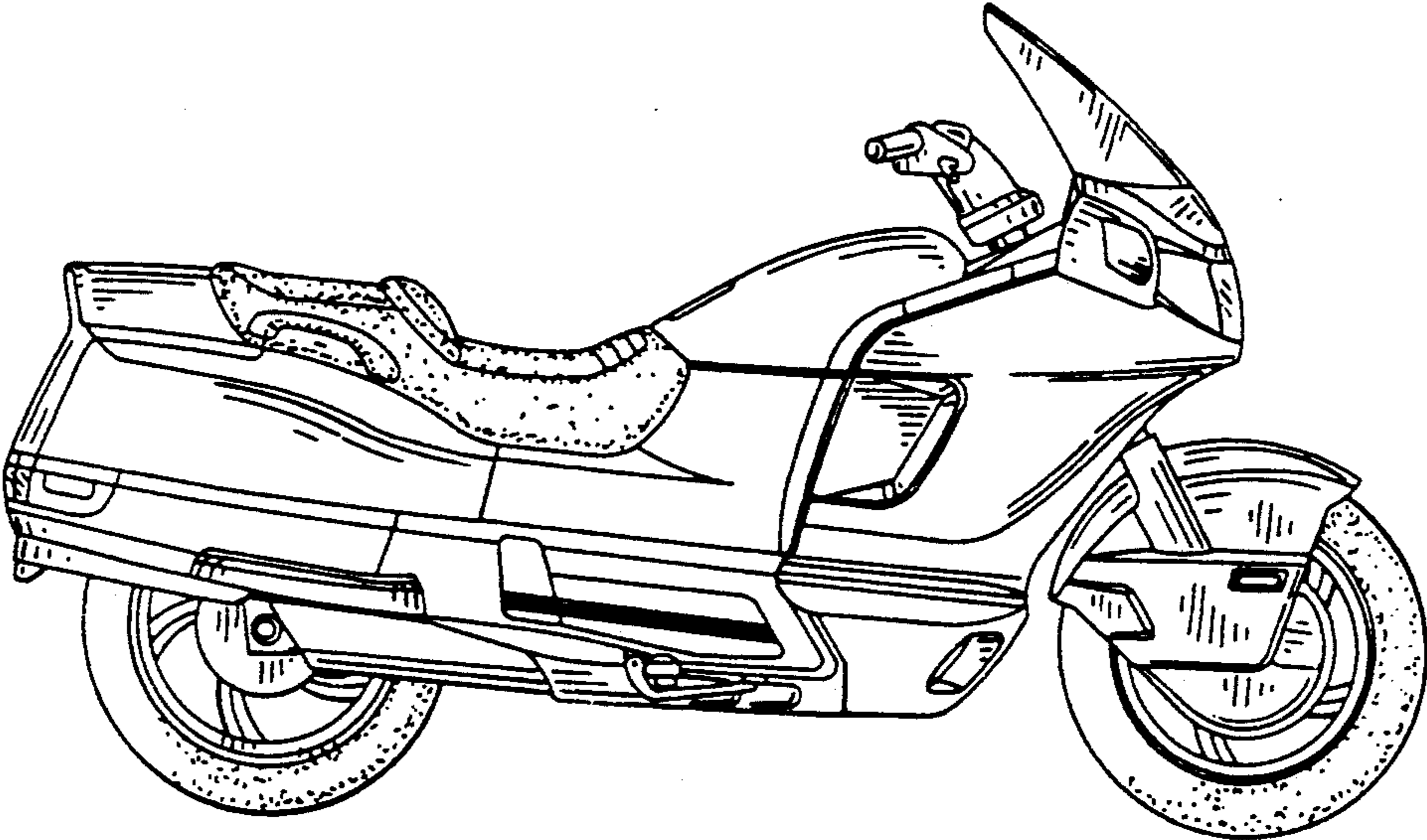

Fig. 2

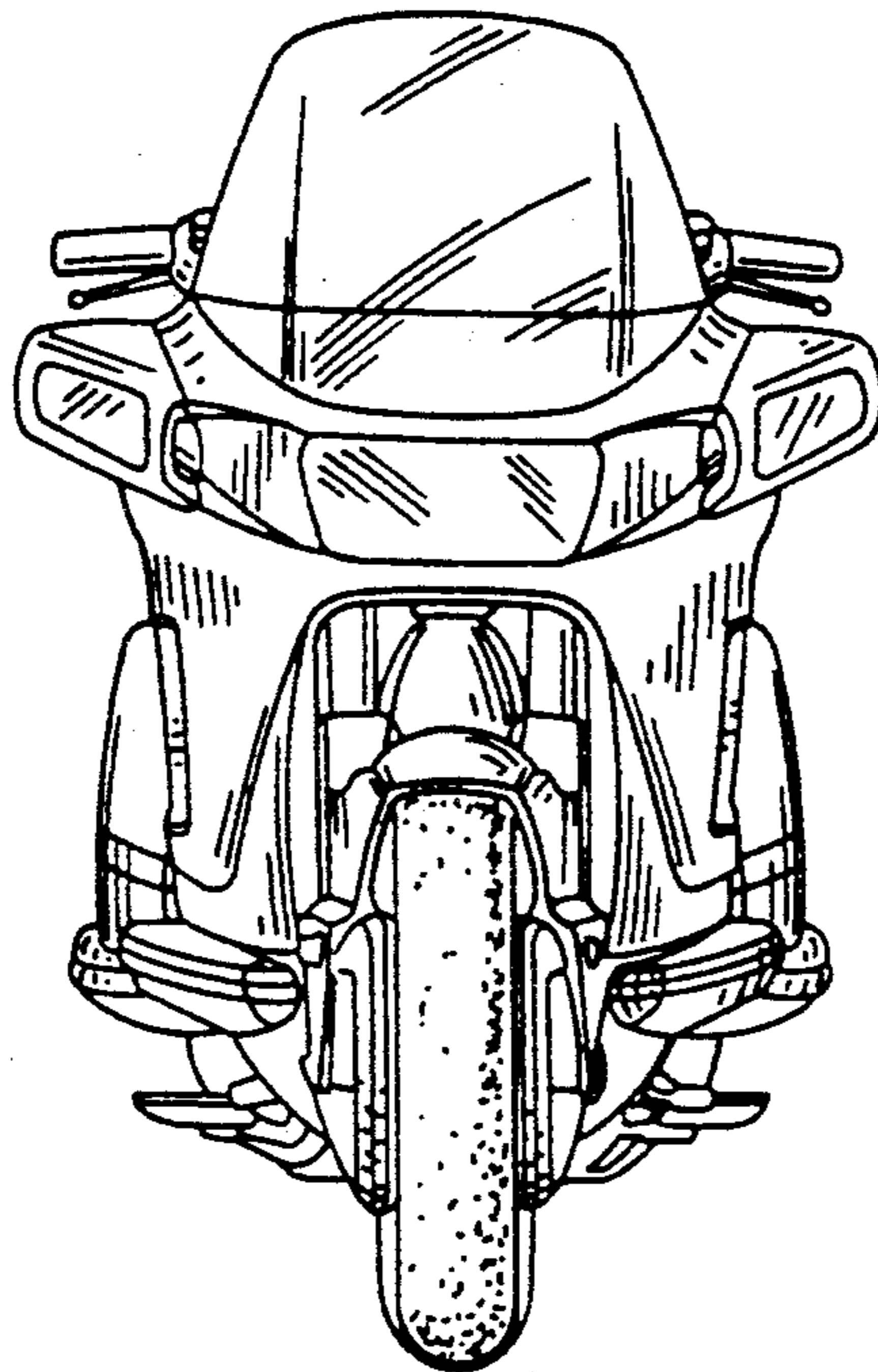

Fig. 3

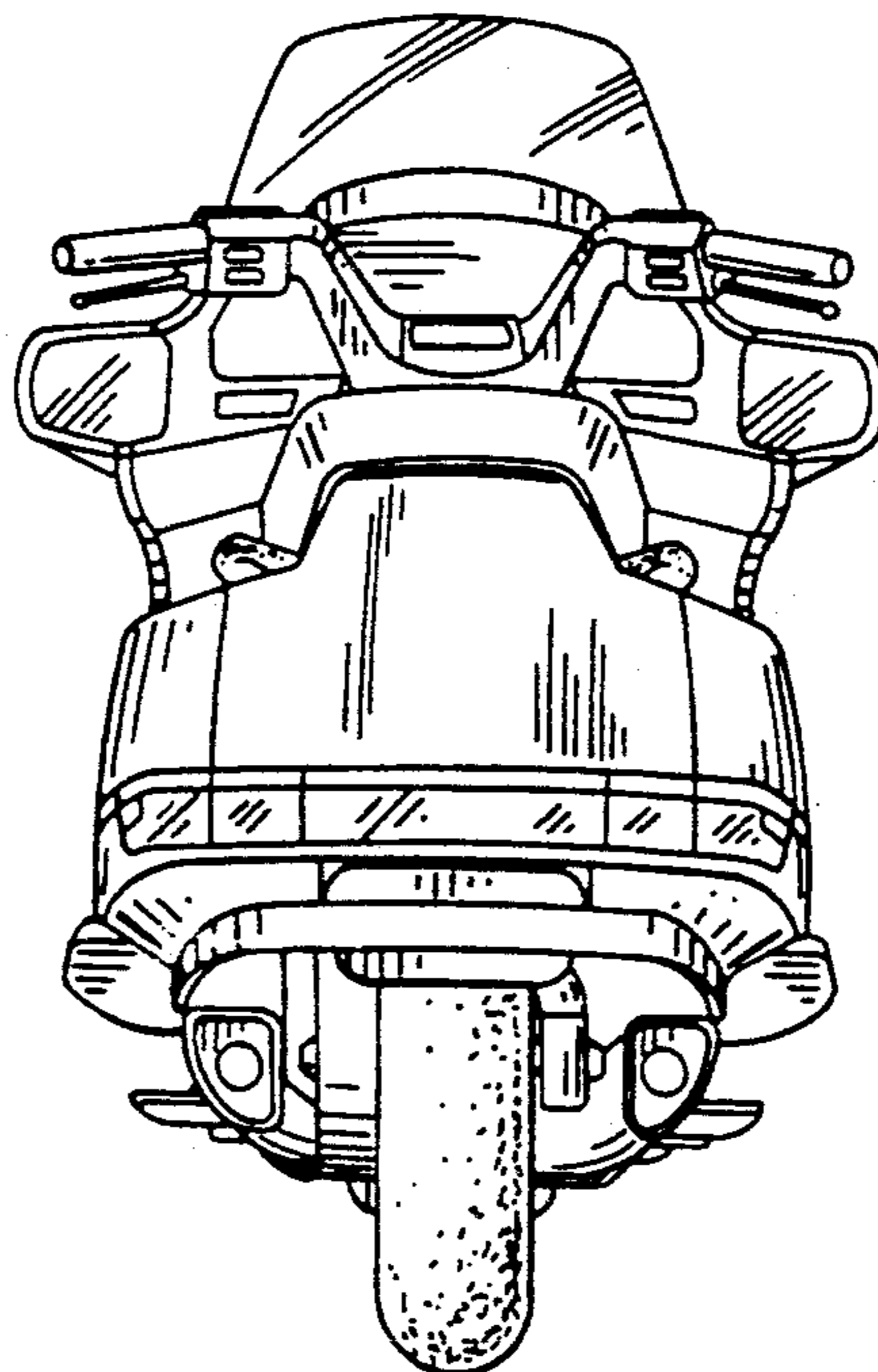

Fig. 4

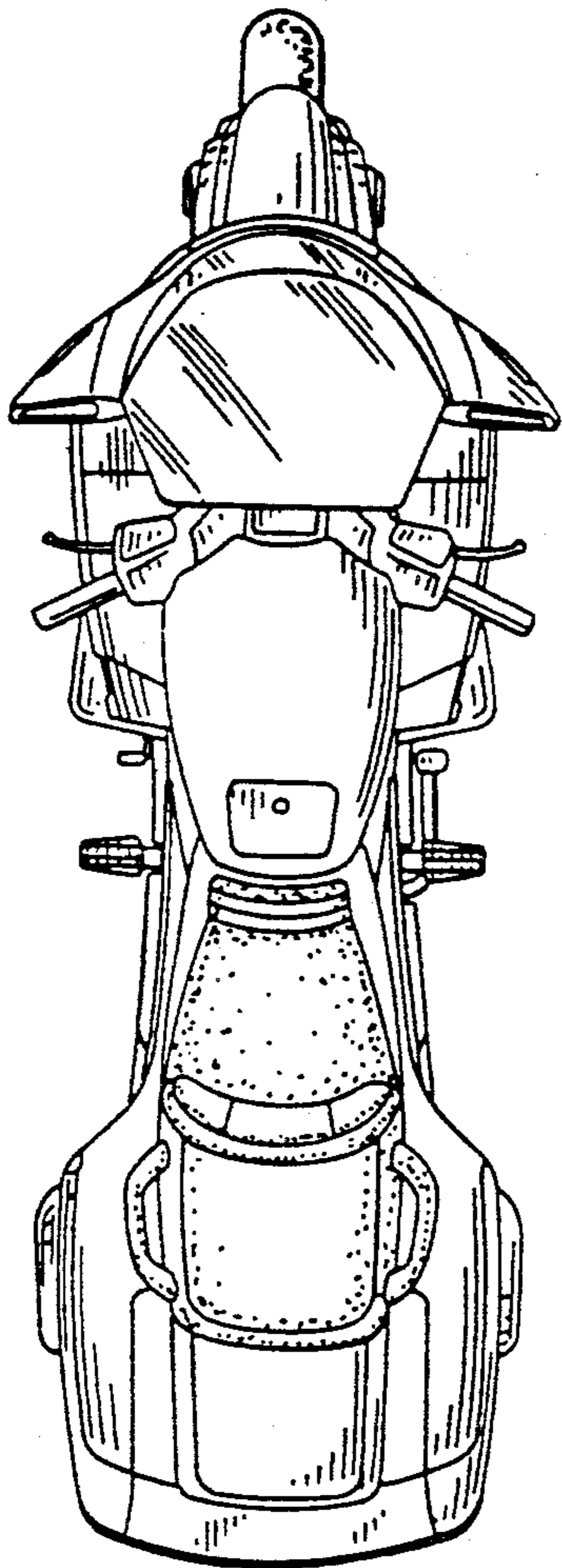

Fig. 5

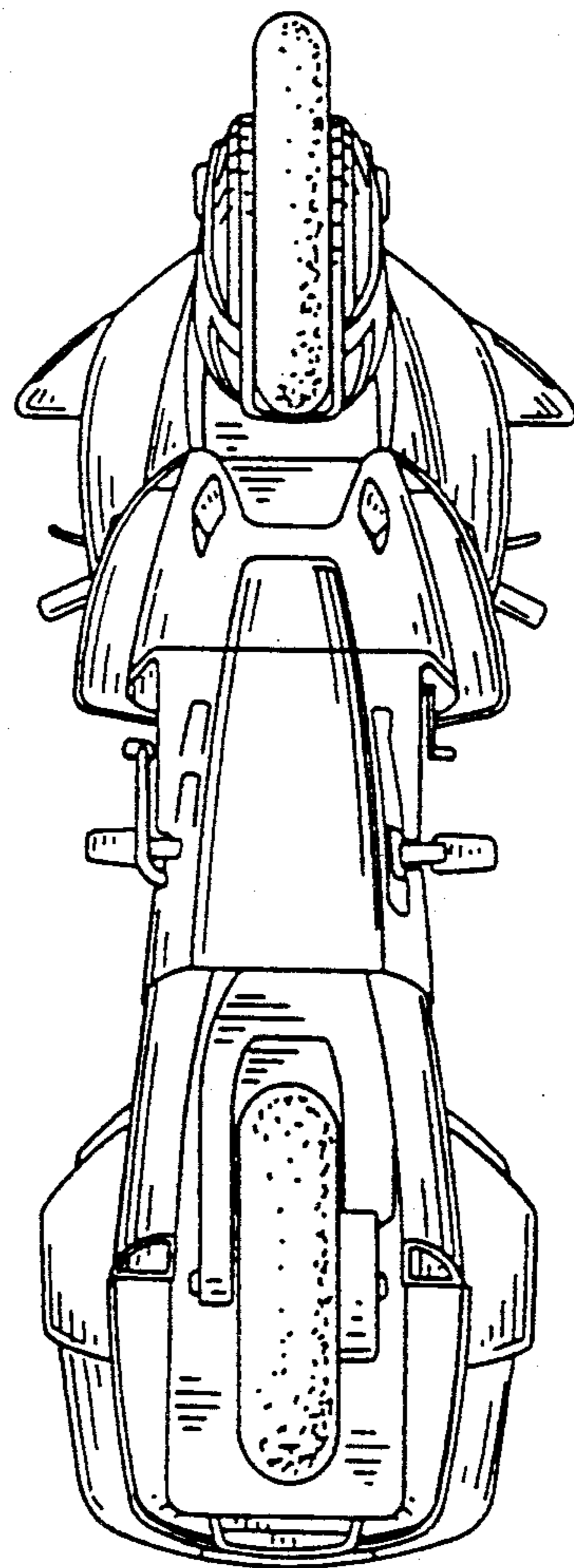

Fig. 6

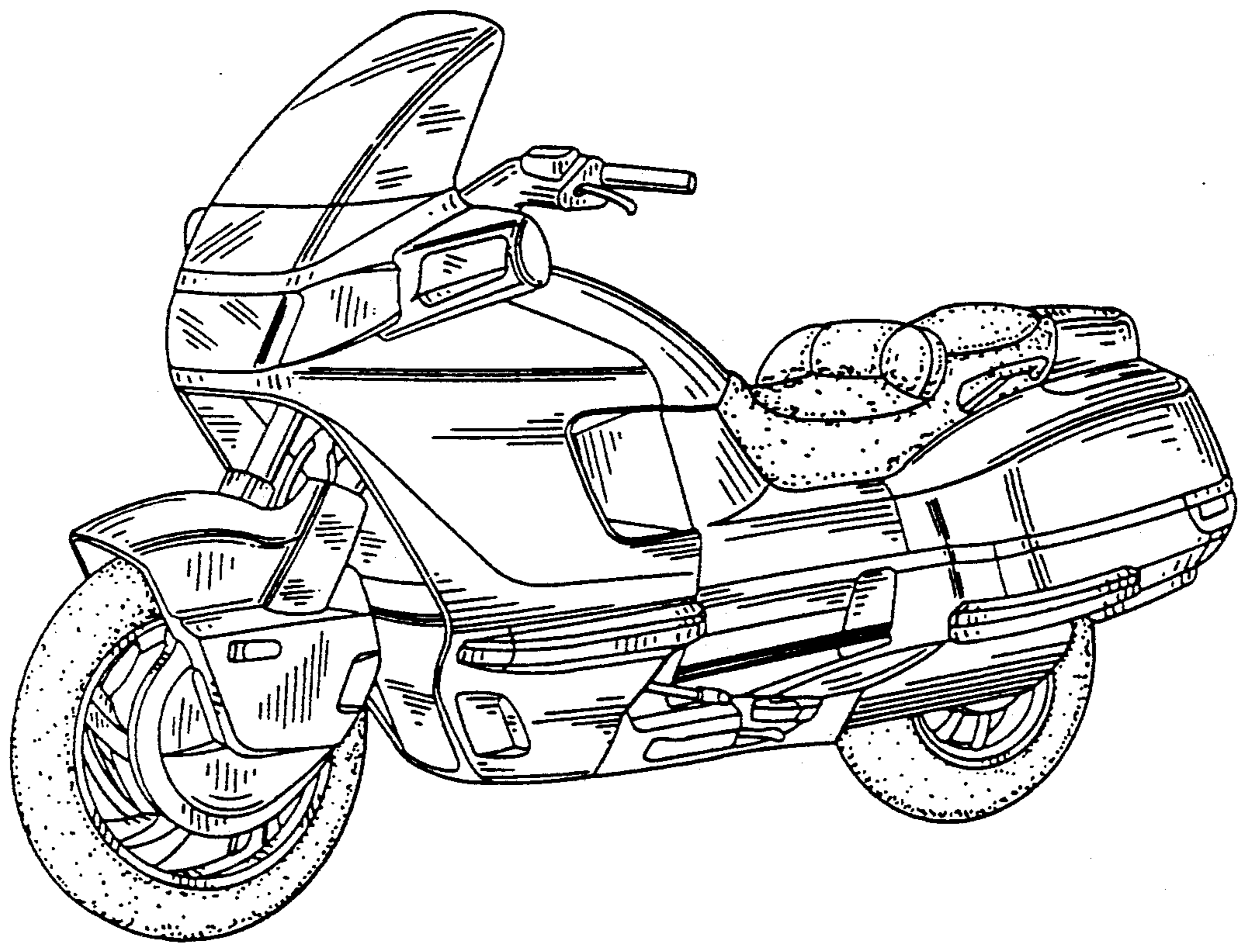

Fig. 7

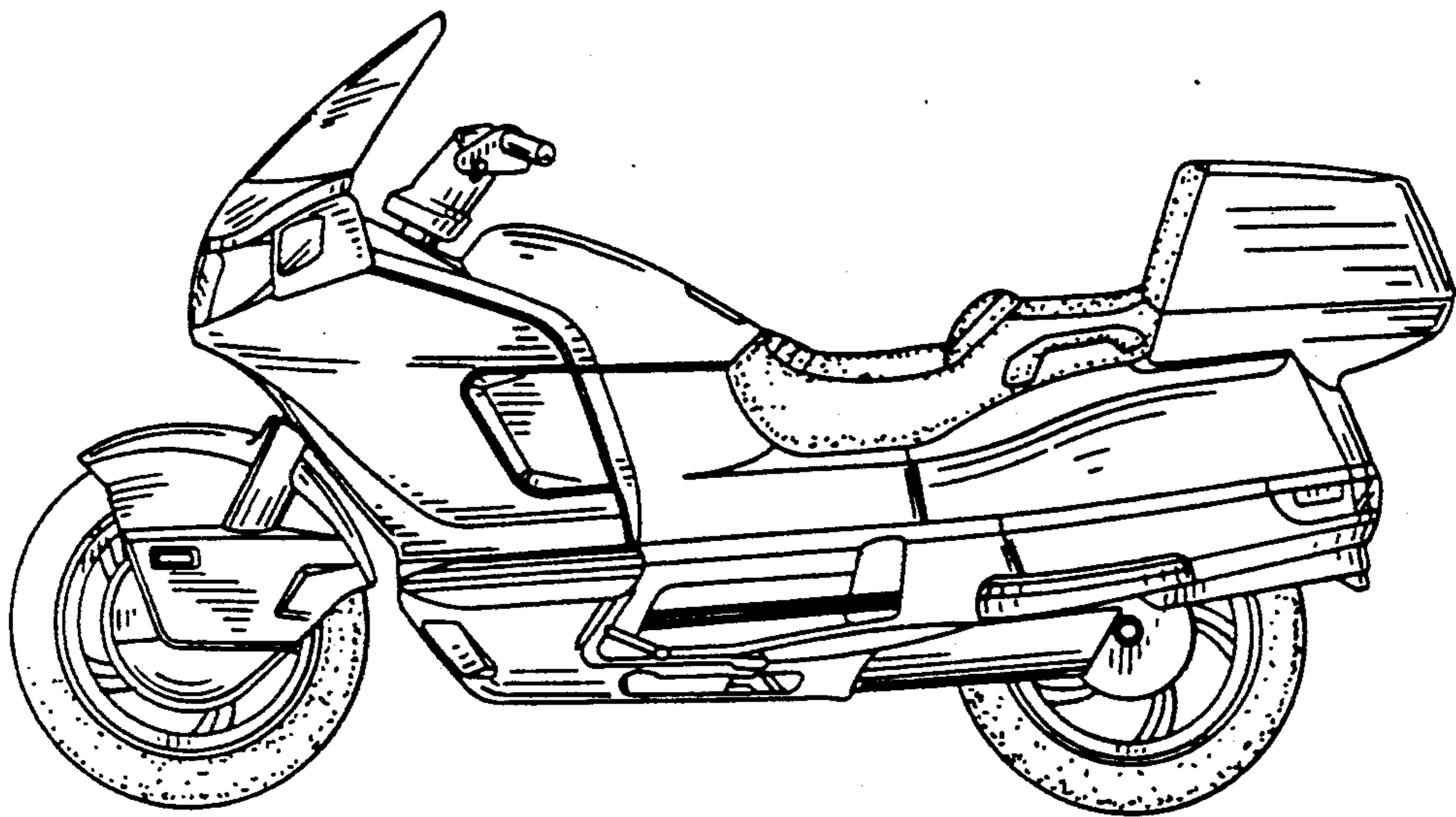

Fig. 8

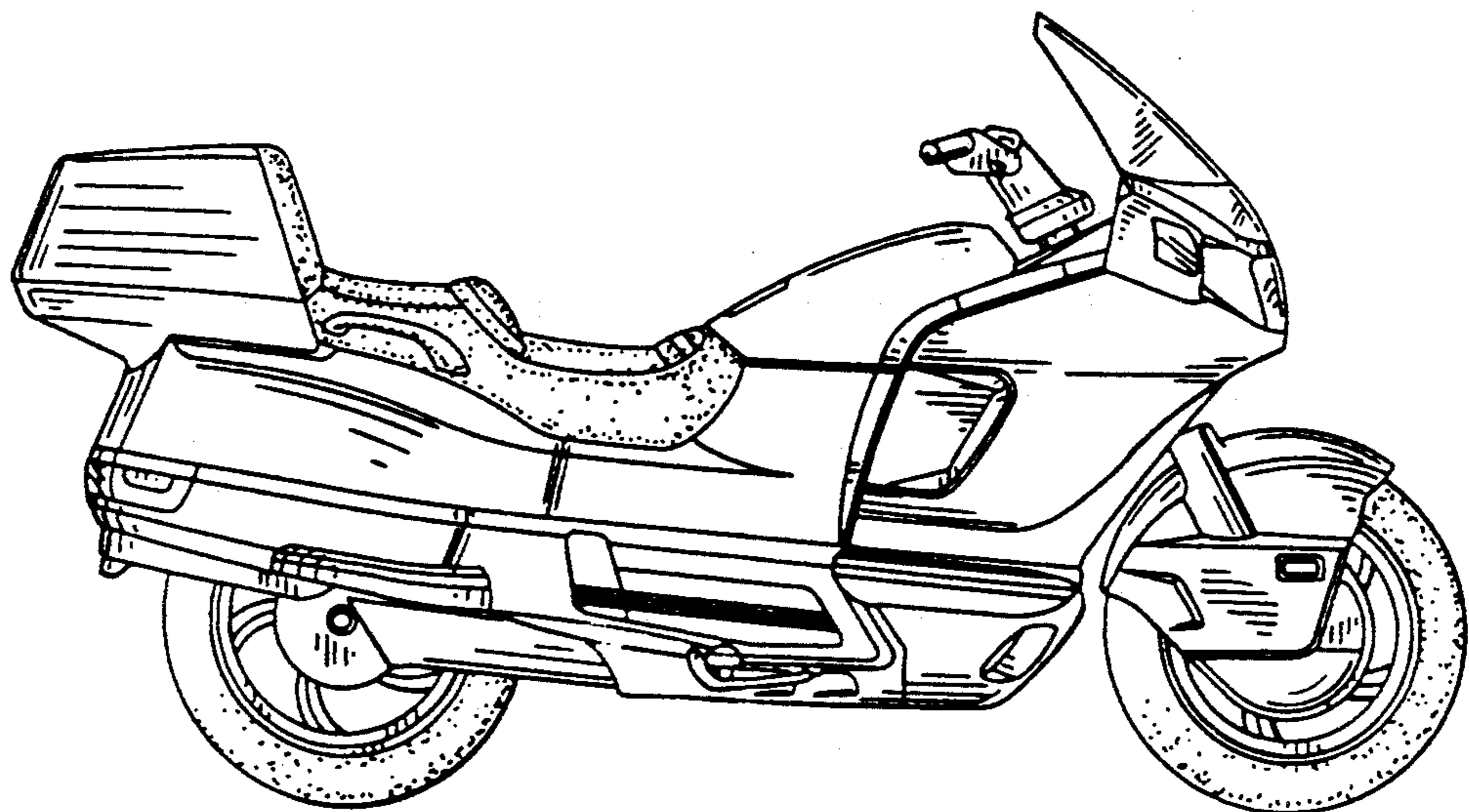

Fig. 9

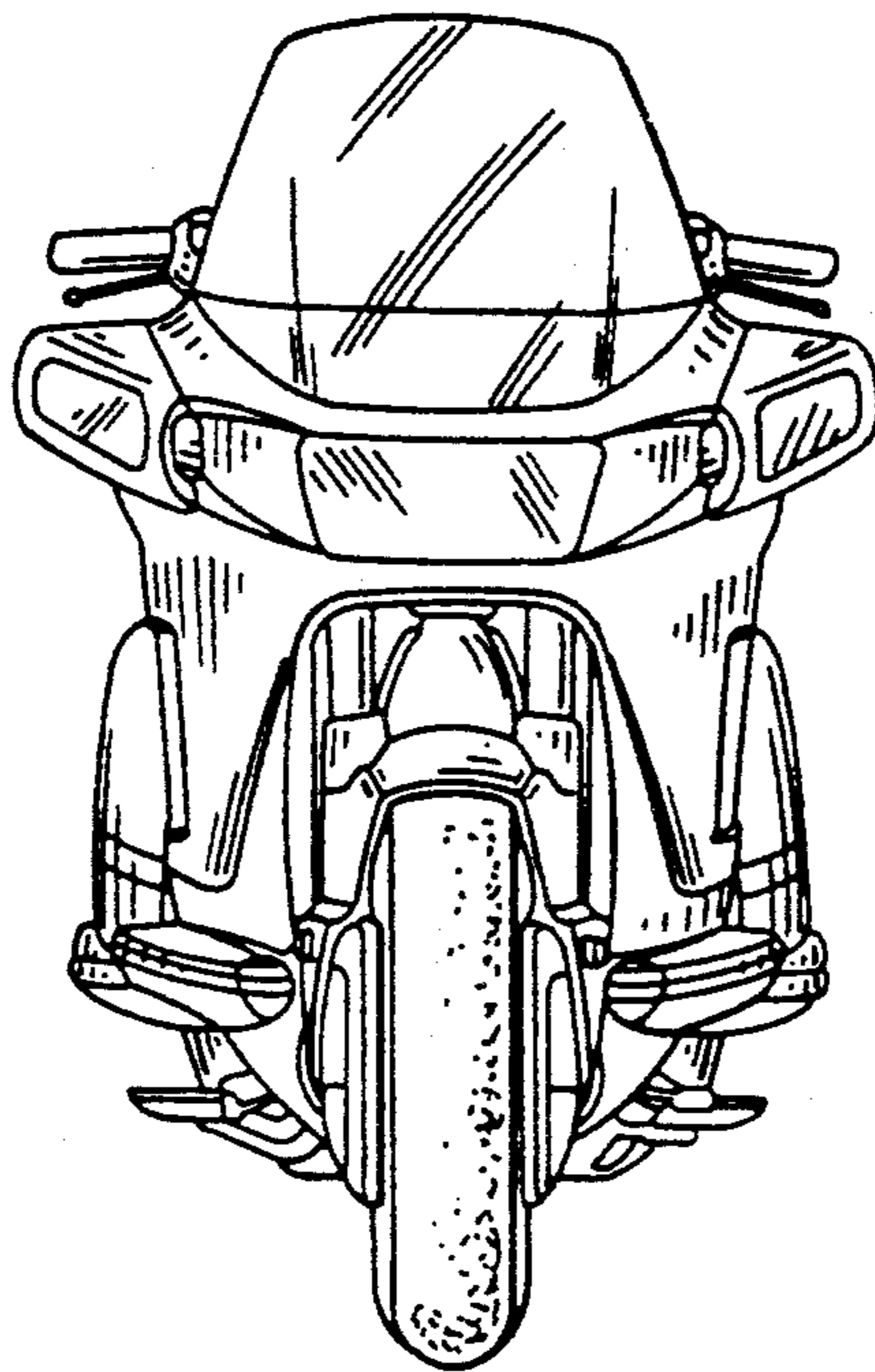

Fig. 10

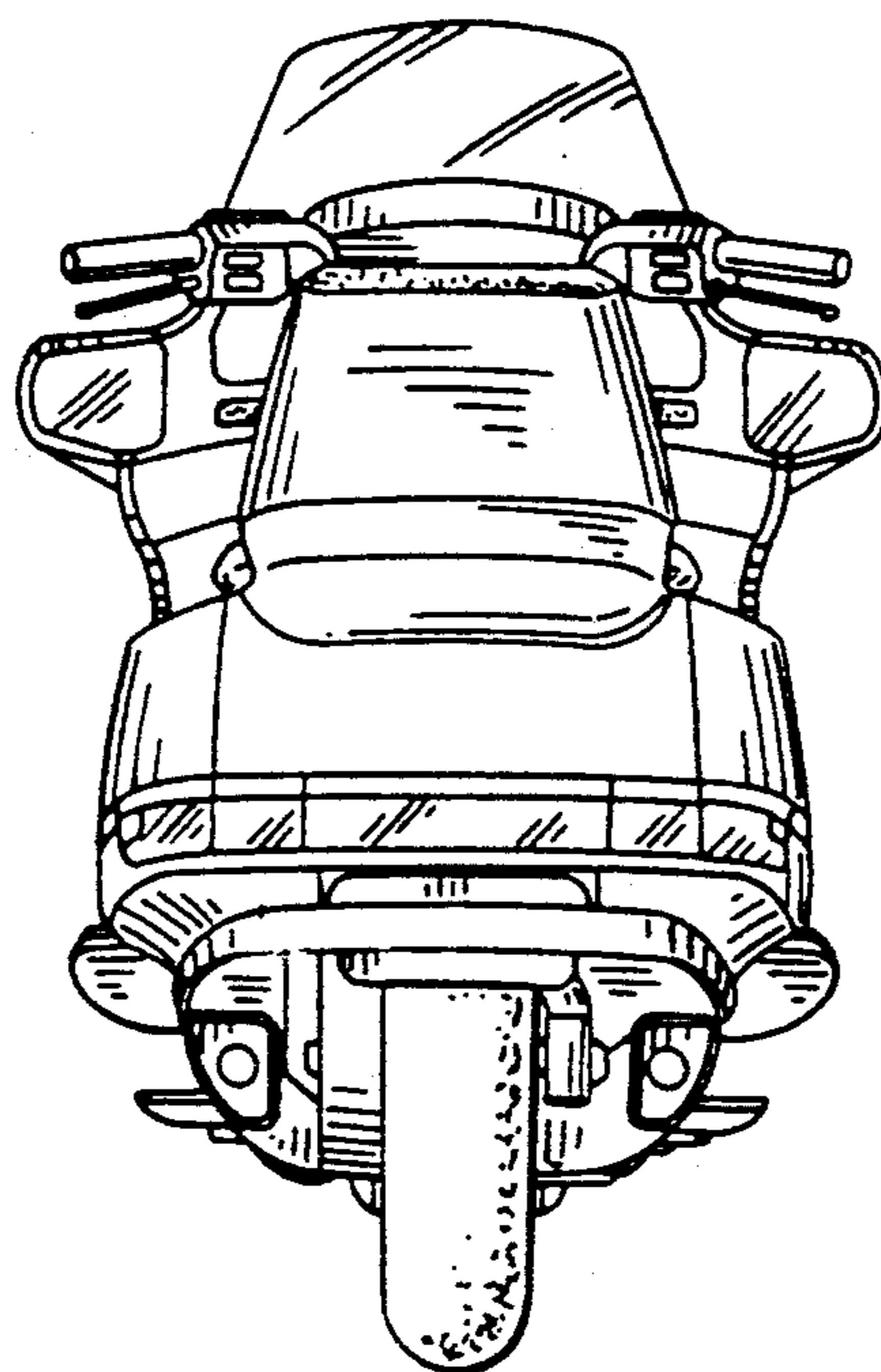

Fig. 11

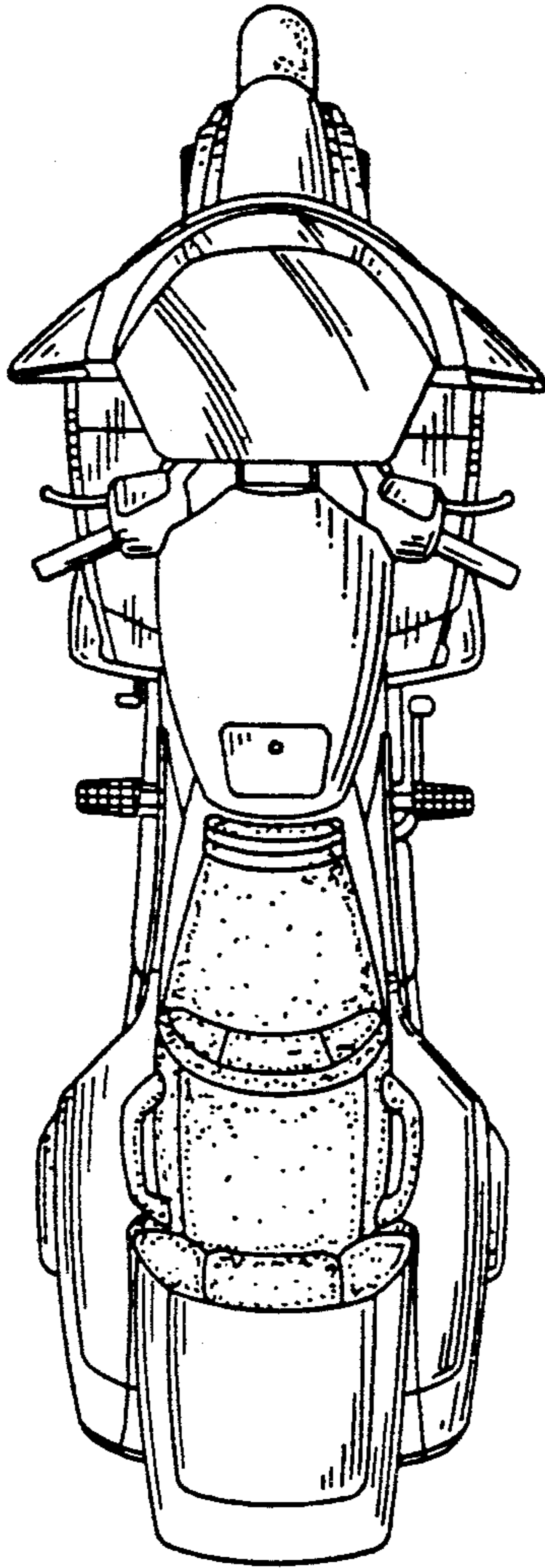

Fig. 12

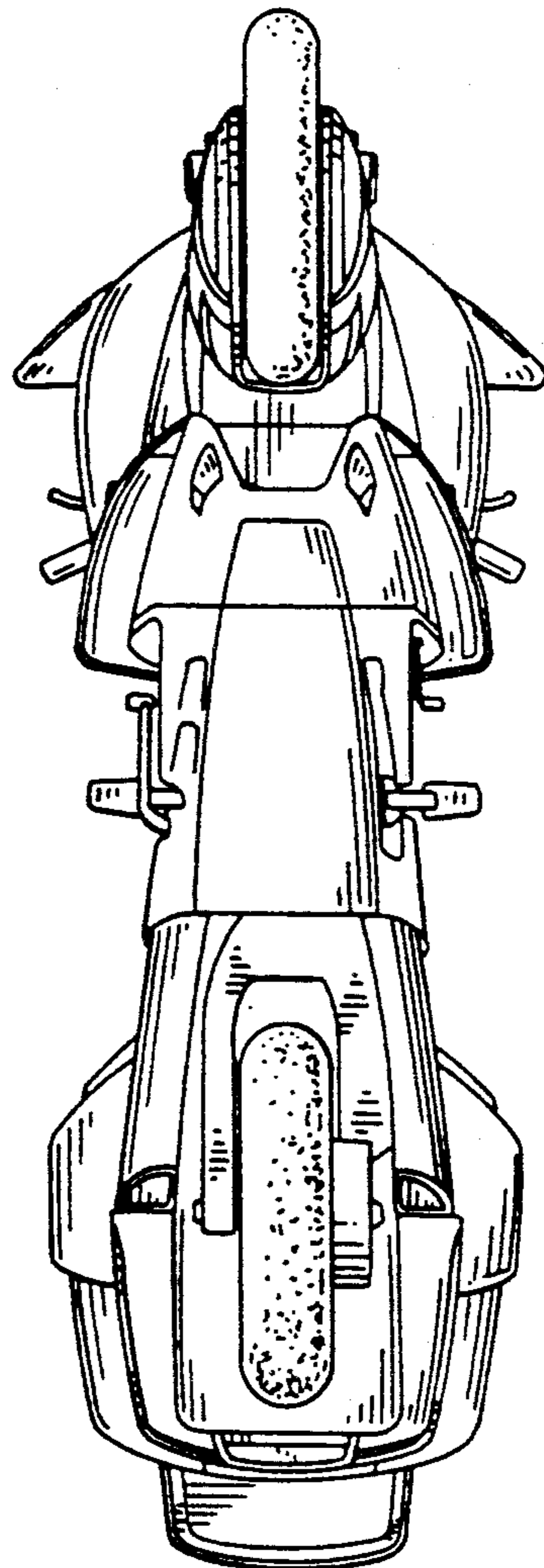

Fig. 13

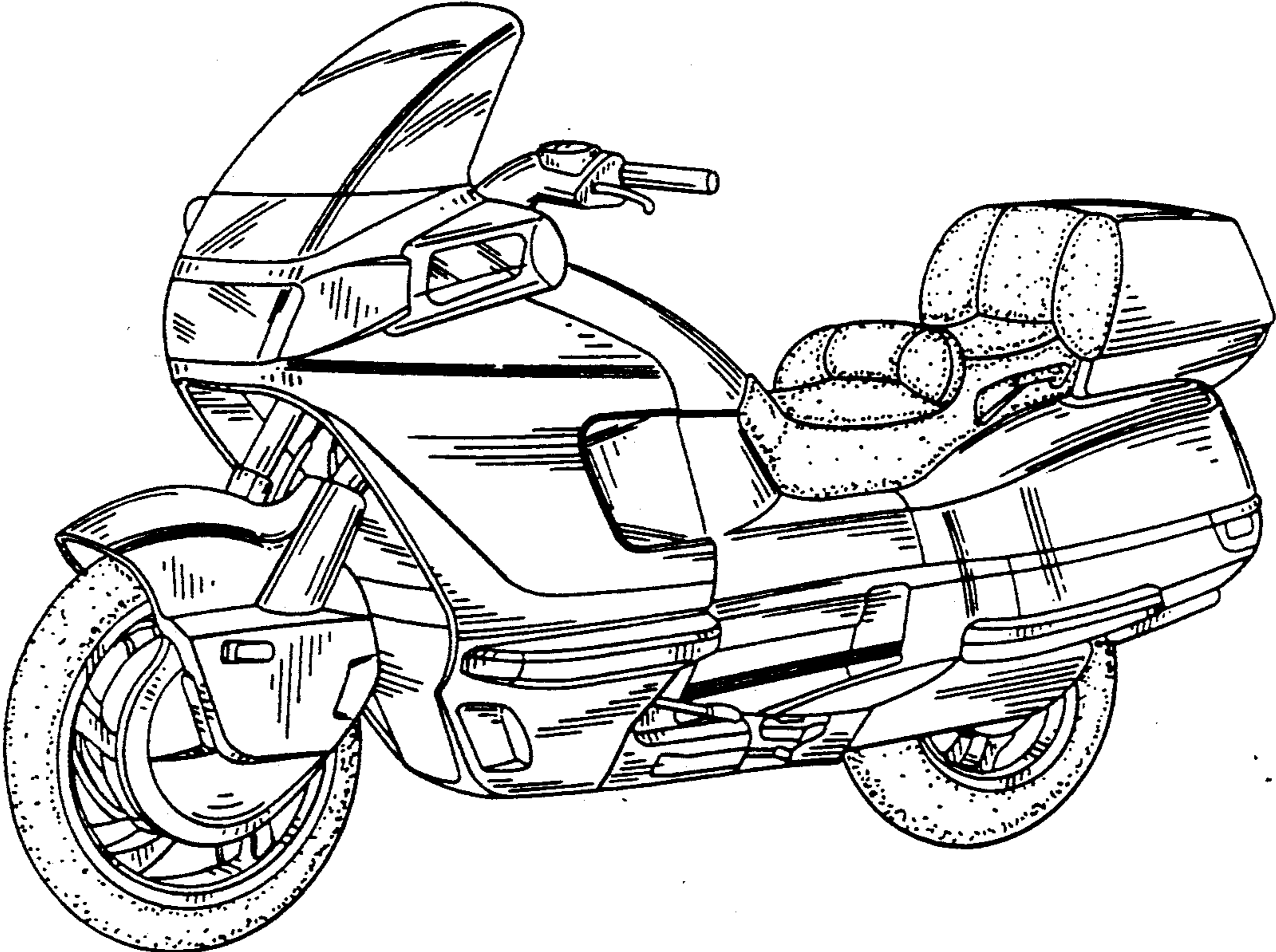

Fig. 14

UNITED STATES PATENT AND TRADEMARK OFFICE
CERTIFICATE OF CORRECTION

PATENT NO. : Des. 321,676
DATED : November 19, 1991
INVENTOR(S) : Makoto KITAGAWA et al

It is certified that error appears in the above-identified patent and that said Letters Patent is hereby corrected as shown below:

On the cover page, Item [75], second line, "Elizi" should read -- Eizi --.

Signed and Sealed this
Thirteenth Day of April, 1993

Attest:

Attesting Officer

STEPHEN G. KUNIN

Acting Commissioner of Patents and Trademarks