

- [54] **VEHICLE**  
 [75] **Inventor: Arunas P. Oslapas, Holland, Mich.**  
 [73] **Assignee: JWI, Inc., Holland, Mich.**  
 [\*\*] **Term: 14 Years**  
 [21] **Appl. No.: 367,216**  
 [22] **Filed: Jun. 16, 1989**  
 [52] **U.S. Cl. .... D12/85; D12/1**  
 [58] **Field of Search .... D12/1, 14, 85;**  
 180/19.2, 65.1, 211, 215, 216; 280/87.01

Brochure: Club Car's New Concept for Utility Vehicles, Club Car, Inc. (8 pages) published prior to 6/89.  
 Brochure: Baker Moto-Truc Explosion Proof Trucks, Baker Material Handling Corporation (8 pages) published prior to 6/89.

*Primary Examiner*—James M. Gandy  
*Attorney, Agent, or Firm*—Flynn, Thiel, Boutell & Tanis

[56] **References Cited**

**U.S. PATENT DOCUMENTS**

D. 211,982	8/1968	Reed	.....	D12/1
D. 223,335	11/1972	Satterfield	.....	D12/14
D. 242,335	11/1976	Cooper et al.	.....	D12/1
D. 267,084	11/1982	Bittinger	.....	D12/85
3,168,156	2/1965	Ulinski	.....	280/87.01
4,716,980	1/1988	Butler	.....	D12/1

**OTHER PUBLICATIONS**

- Brochure: Widgit Inside Movers, Ahlstedt Manufacturing Corp. (4 pages) ©1982.  
 Brochure: Cushman Industrial and Commercial Vehicles, Cushman Product Group (32 pages) published prior to 6/89.  
 Brochure: Hijet Multipurpose Off-Road Utility Vehicle, Daihatsu America, Inc. (12 pages) published prior to 6/89.  
 Brochure: Pack Mule Maintenance Vehicle MV-550, Wesley International Corporation (2 pages) published prior to 6/89.  
 Brochure: Pack Mule Stockchaser SC-750, Wesley International Corporation (2 pages) published prior to 6/89.  
 Brochure: Pack Mule Personnel Carrier PC-440, Wesley International Corp. (2 pages) published prior to 6/89.

[57] **CLAIM**

The ornamental design of a vehicle, as shown and described.

**DESCRIPTION**

FIG. 1 is a perspective view of a first embodiment of a vehicle showing my design;  
 FIG. 2 is a top plan view thereof;  
 FIG. 3 is a left side elevational view thereof;  
 FIG. 4 is a front elevational view thereof; and  
 FIG. 5 is a right side elevational view thereof;  
 FIG. 6 is a perspective view of a second embodiment of a vehicle showing my design;  
 FIG. 7 is a perspective view of a third embodiment of a vehicle showing my design;  
 FIG. 8 is a perspective view of a fourth embodiment of a vehicle showing my design;  
 FIG. 9 is a top plan view of the fourth embodiment;  
 FIG. 10 is a left side elevational view of the fourth embodiment;  
 FIG. 11 is a perspective view of a fifth embodiment of a vehicle showing my design;  
 FIG. 12 is a top plan view of the fifth embodiment; and  
 FIG. 13 is a left side elevational view of the fifth embodiment, the right side being substantially a mirror image thereof.  
 The right side of the second, third and fourth embodiments of the vehicle are substantially identical to the right side of the first embodiment thereof show in FIG. 5, and the rear surface of all five embodiments of the vehicle is flat and unornamented.

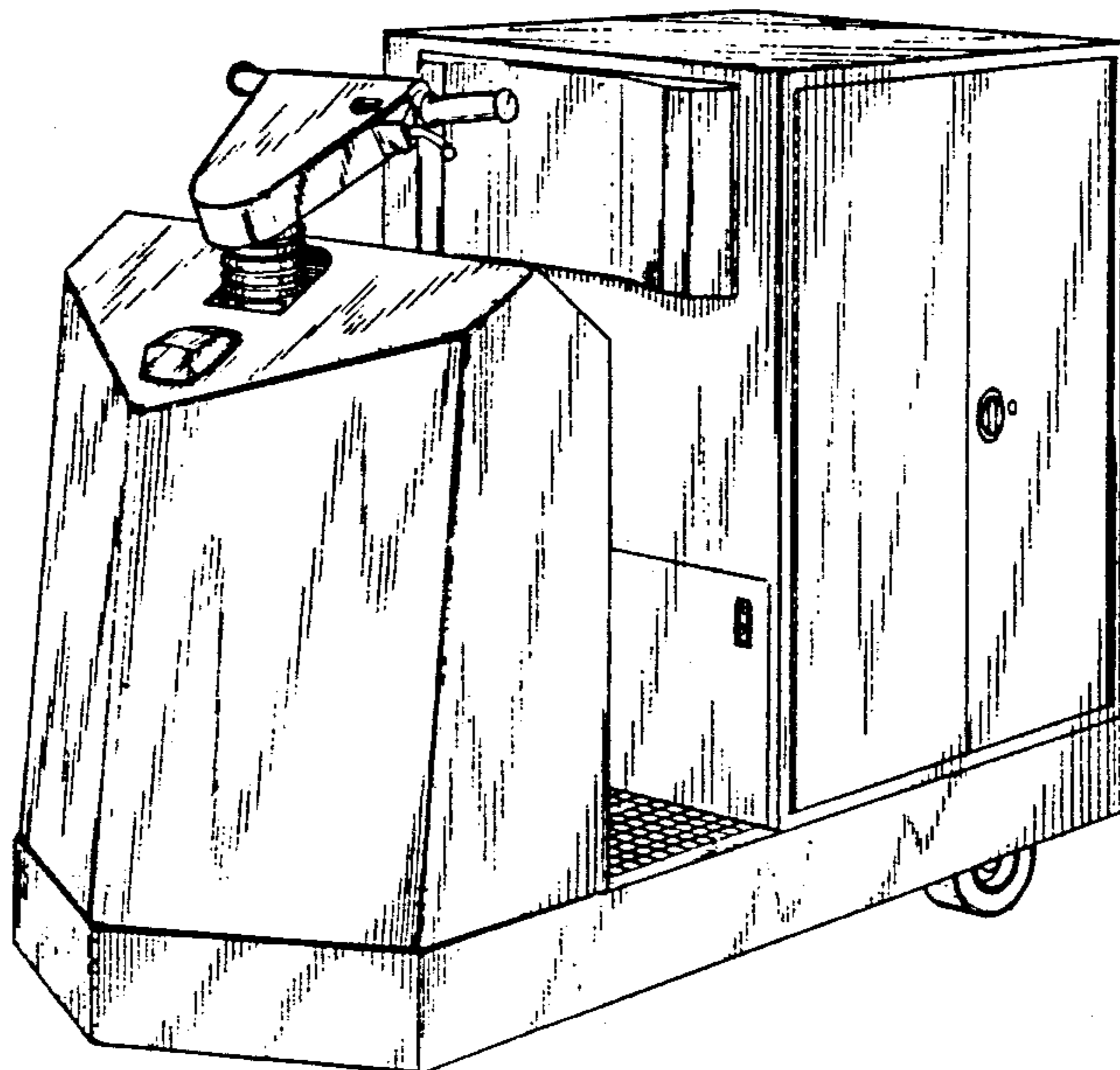

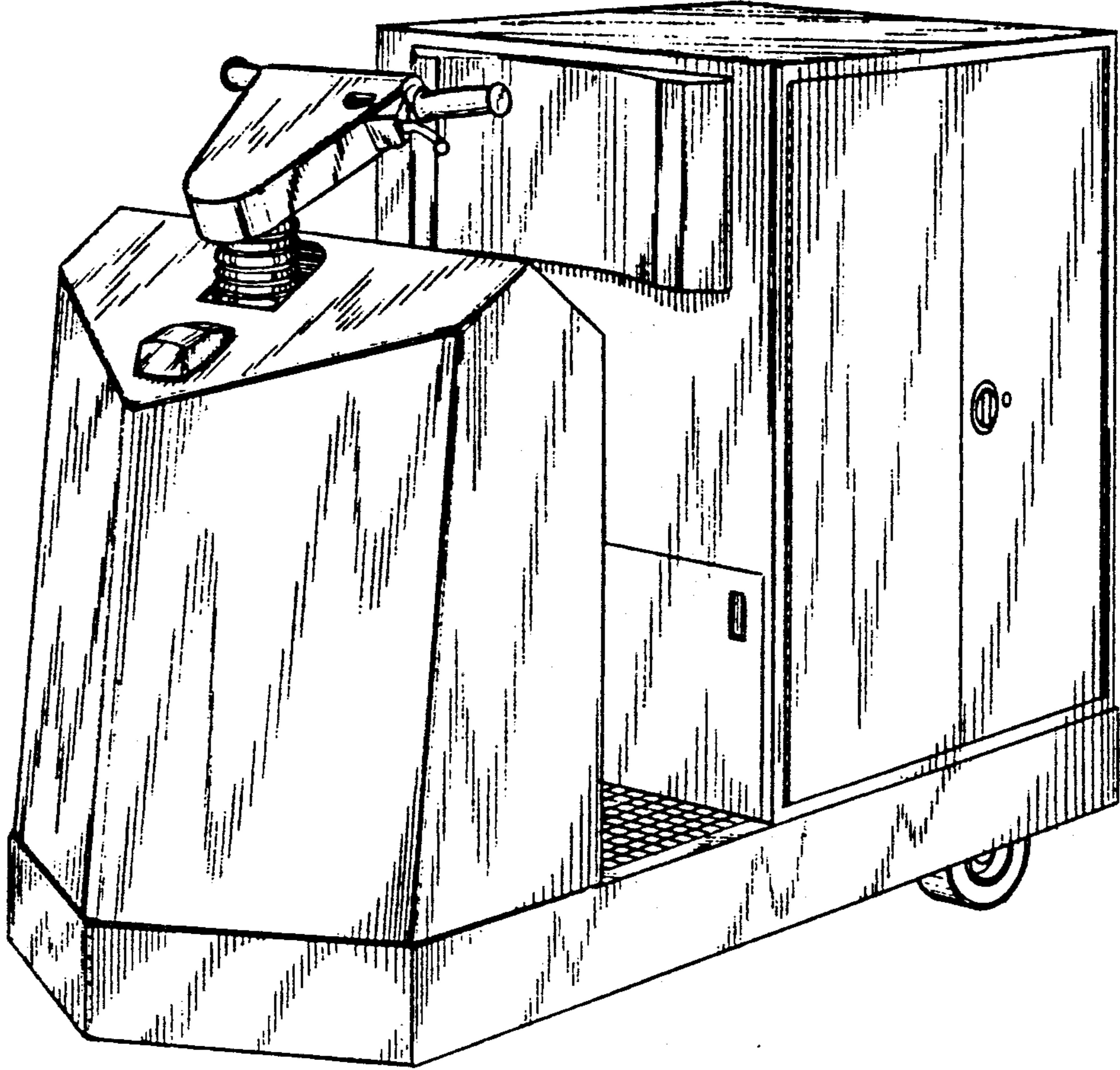

FIG. 1

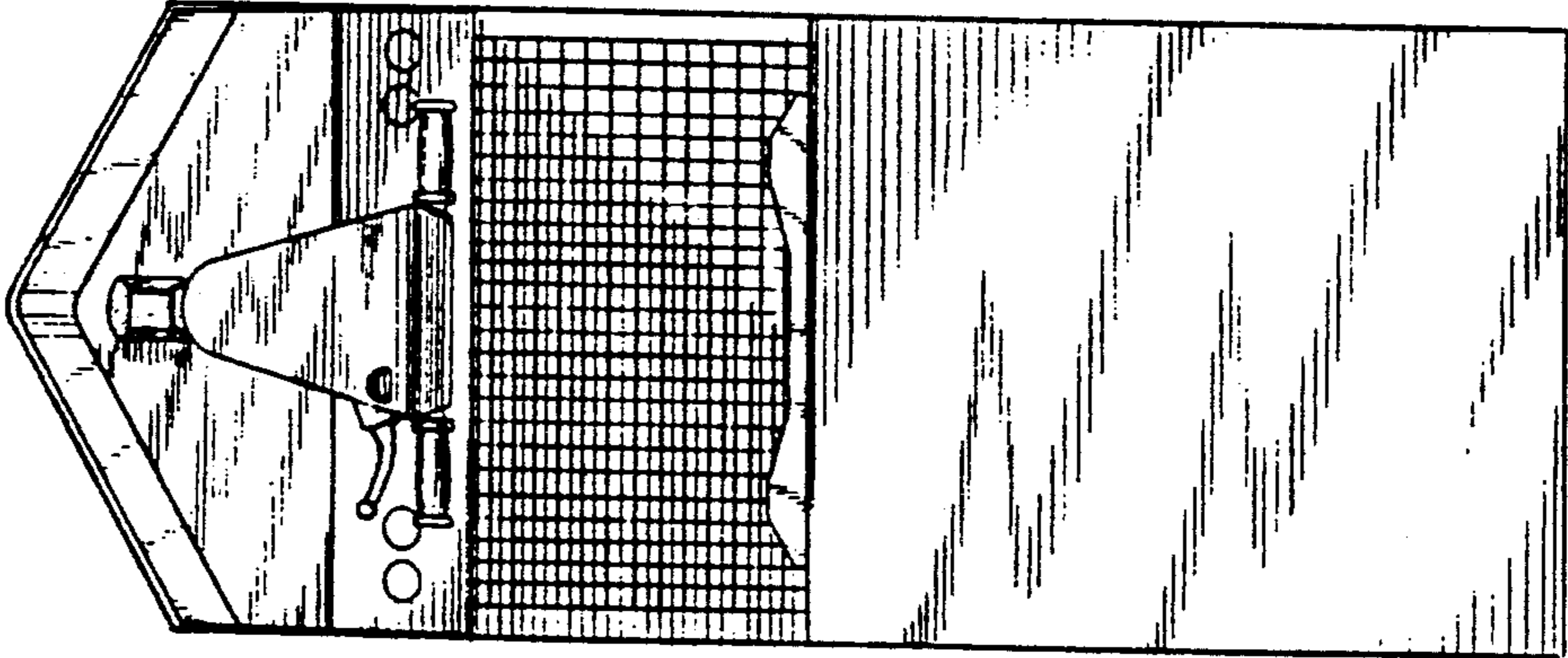

FIG. 2



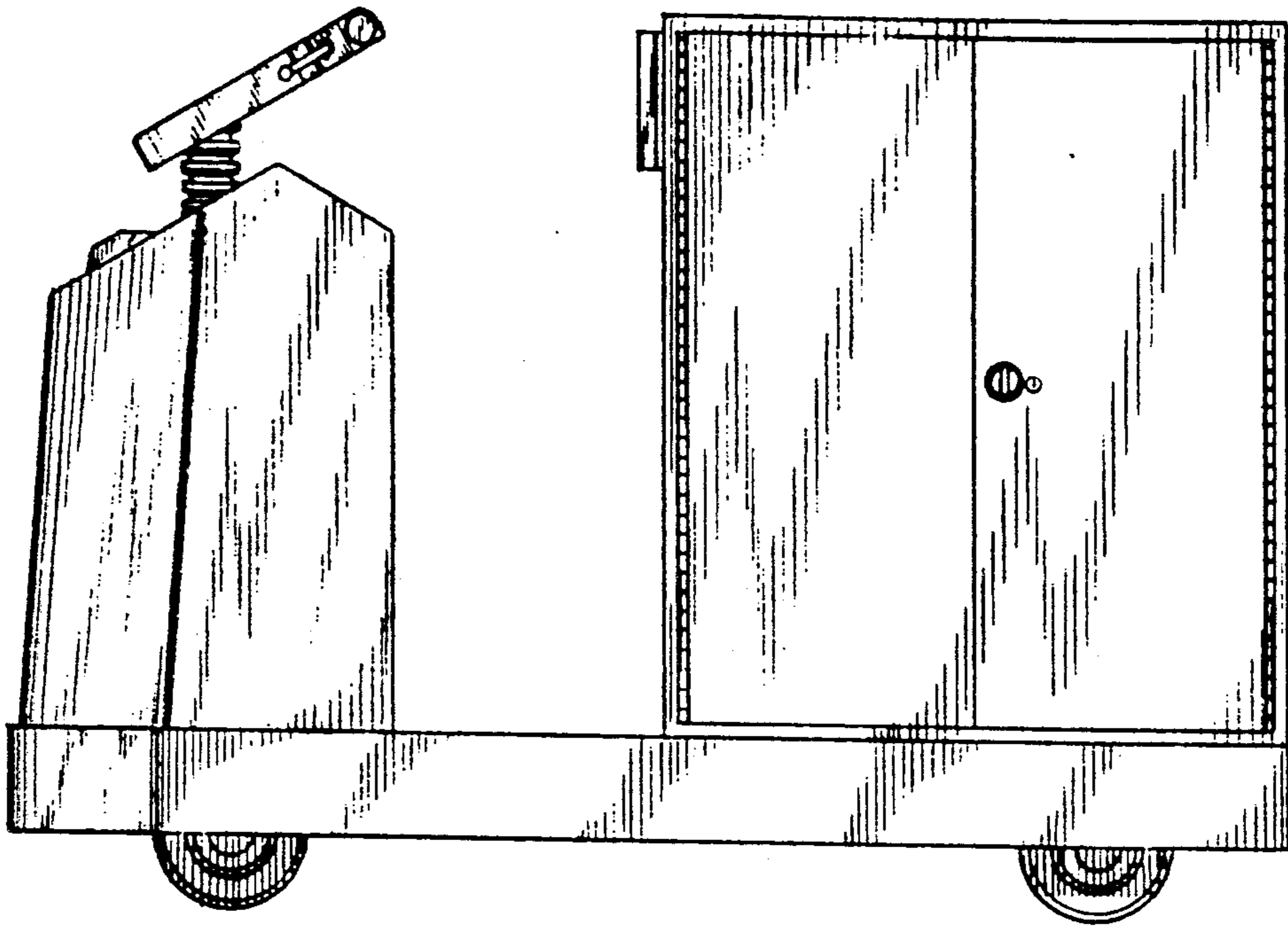

FIG. 3

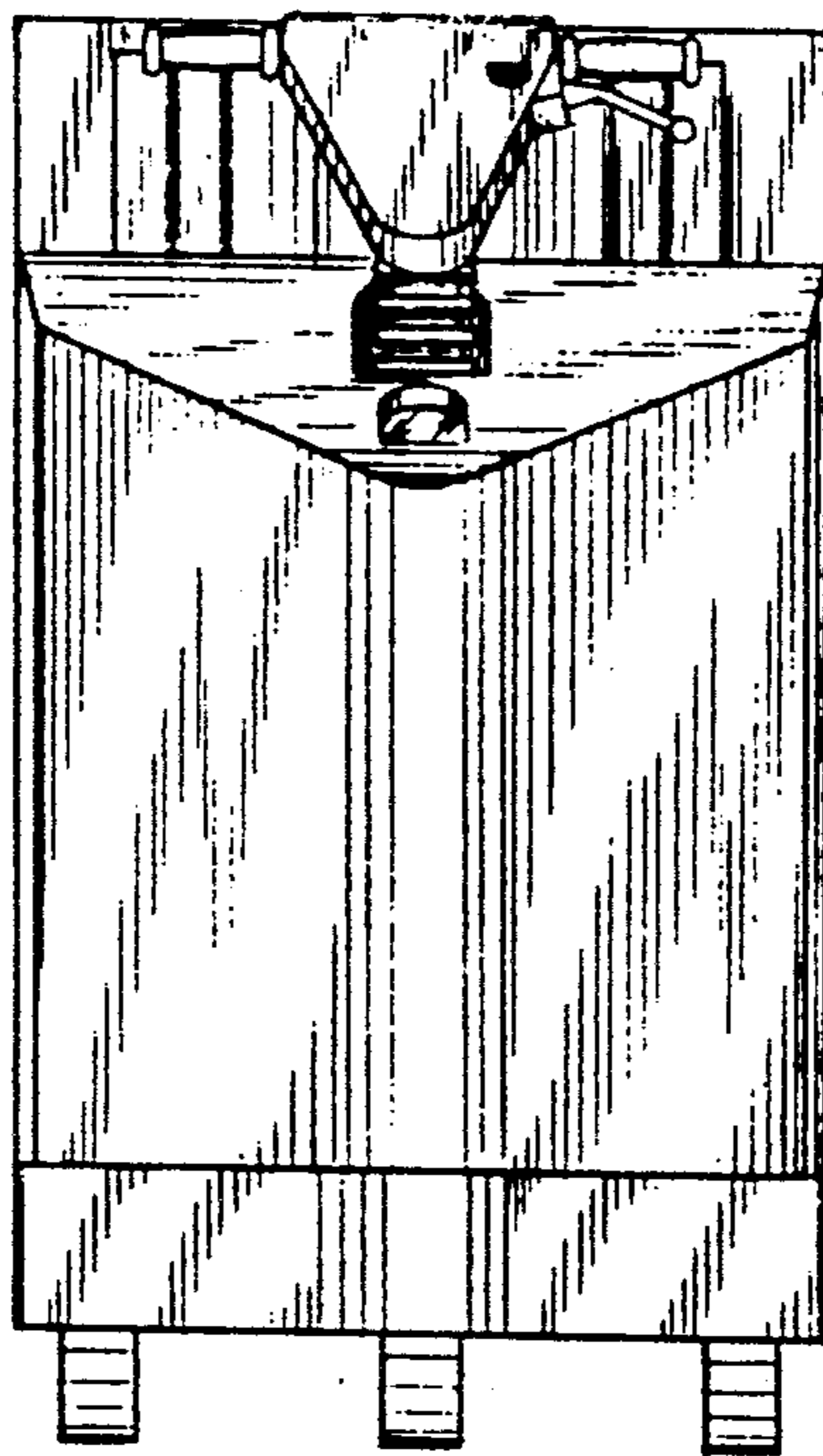

FIG. 4

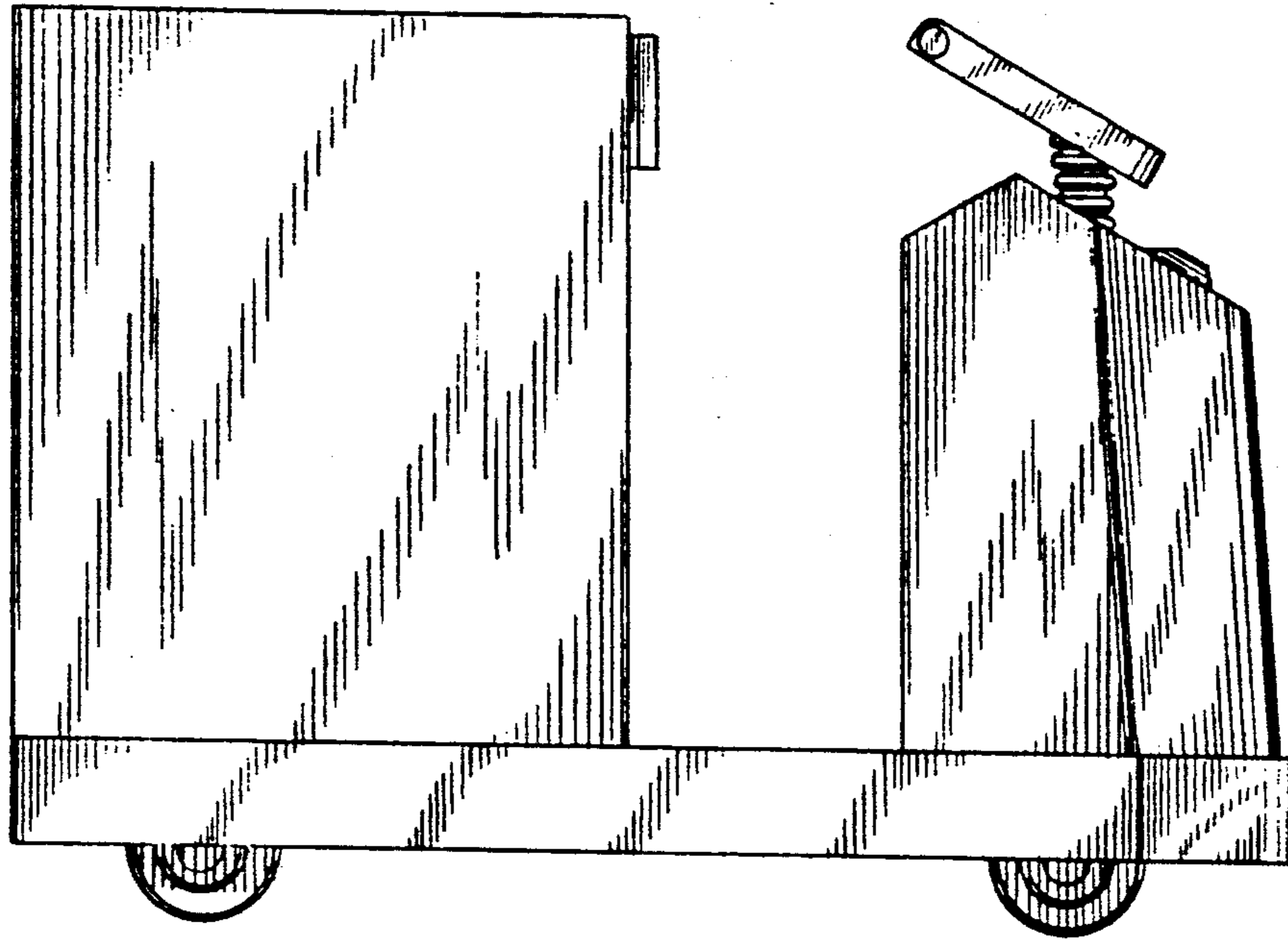

FIG. 5

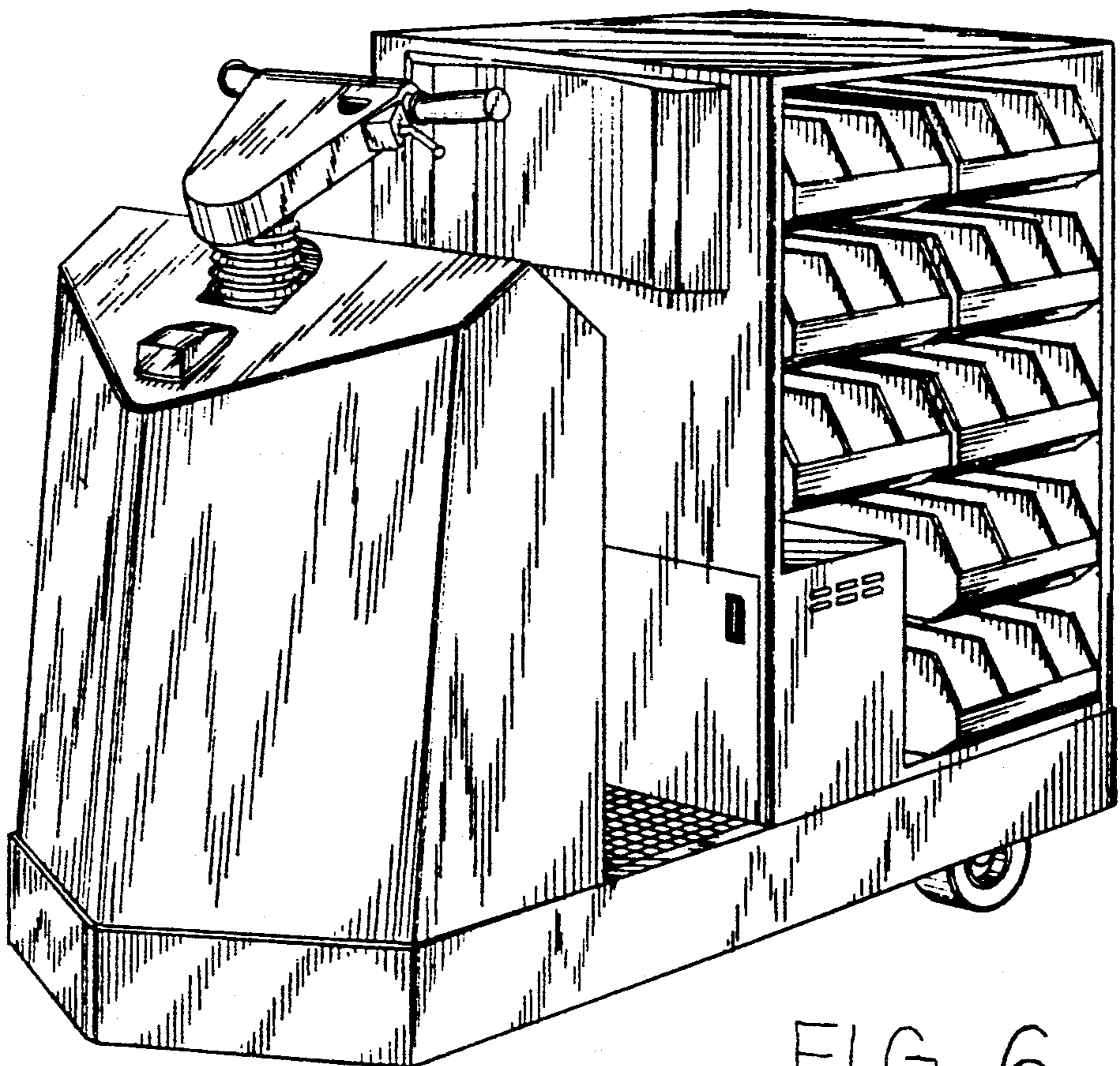

FIG. 6

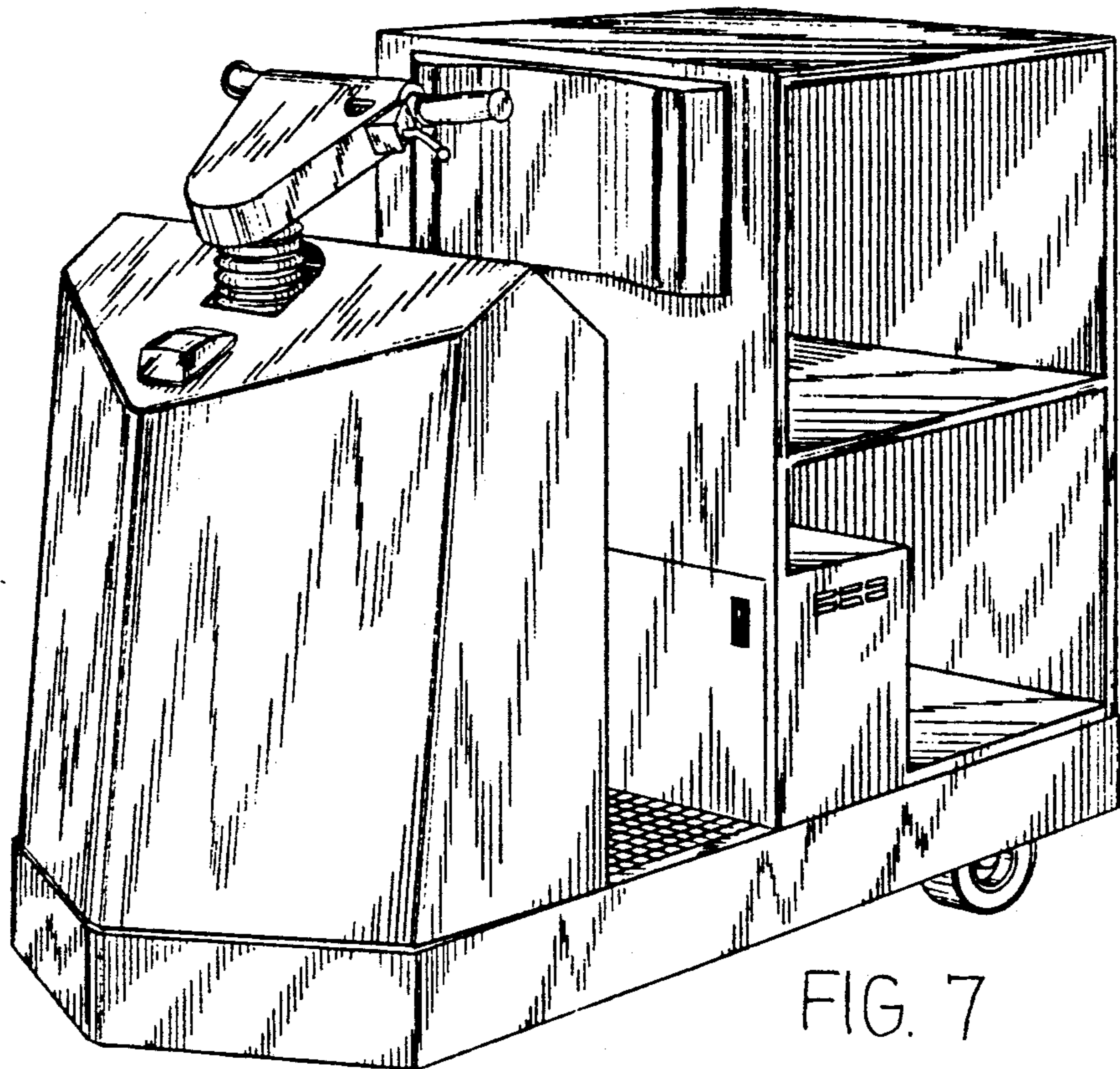

FIG. 7

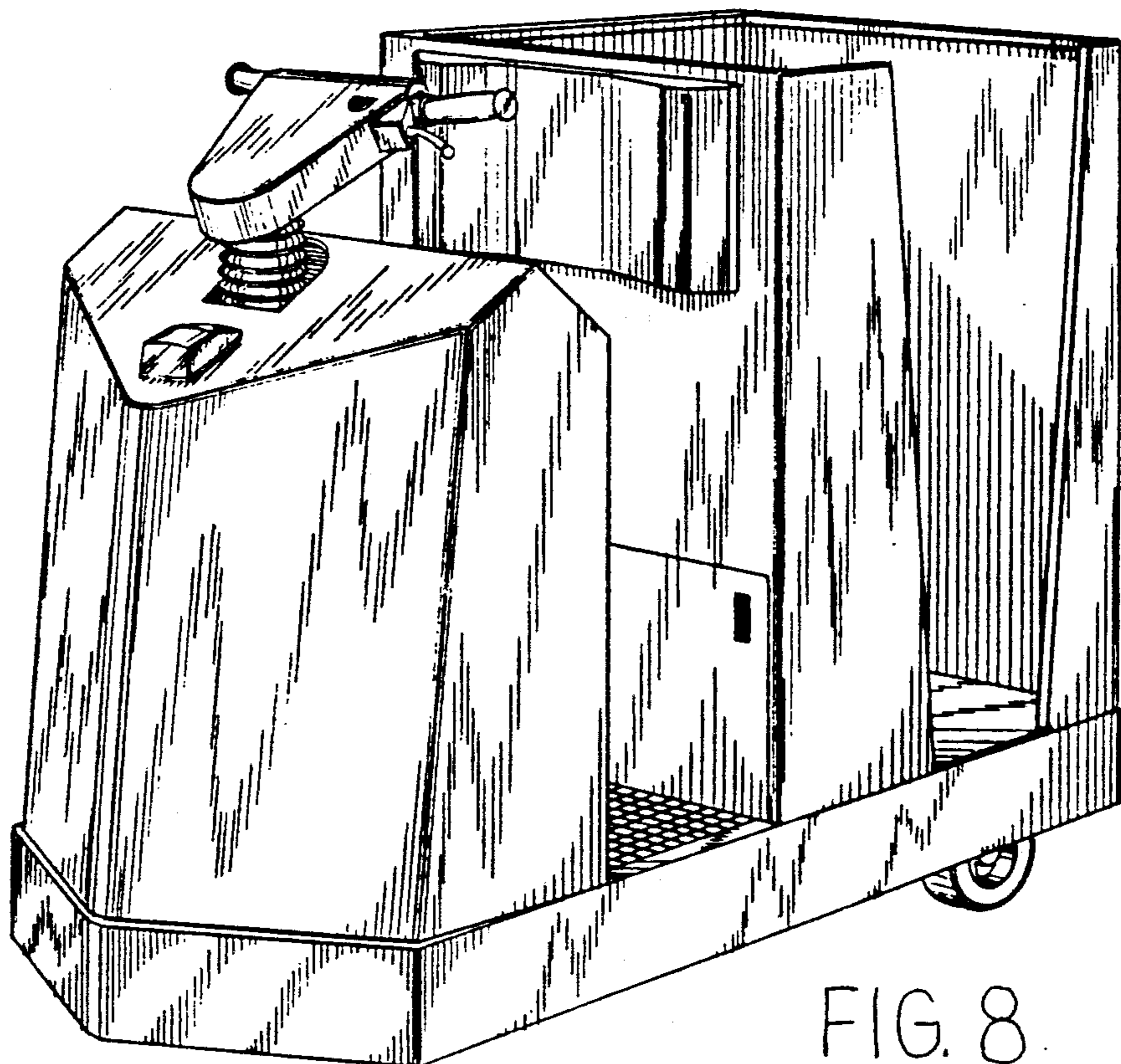

FIG. 8



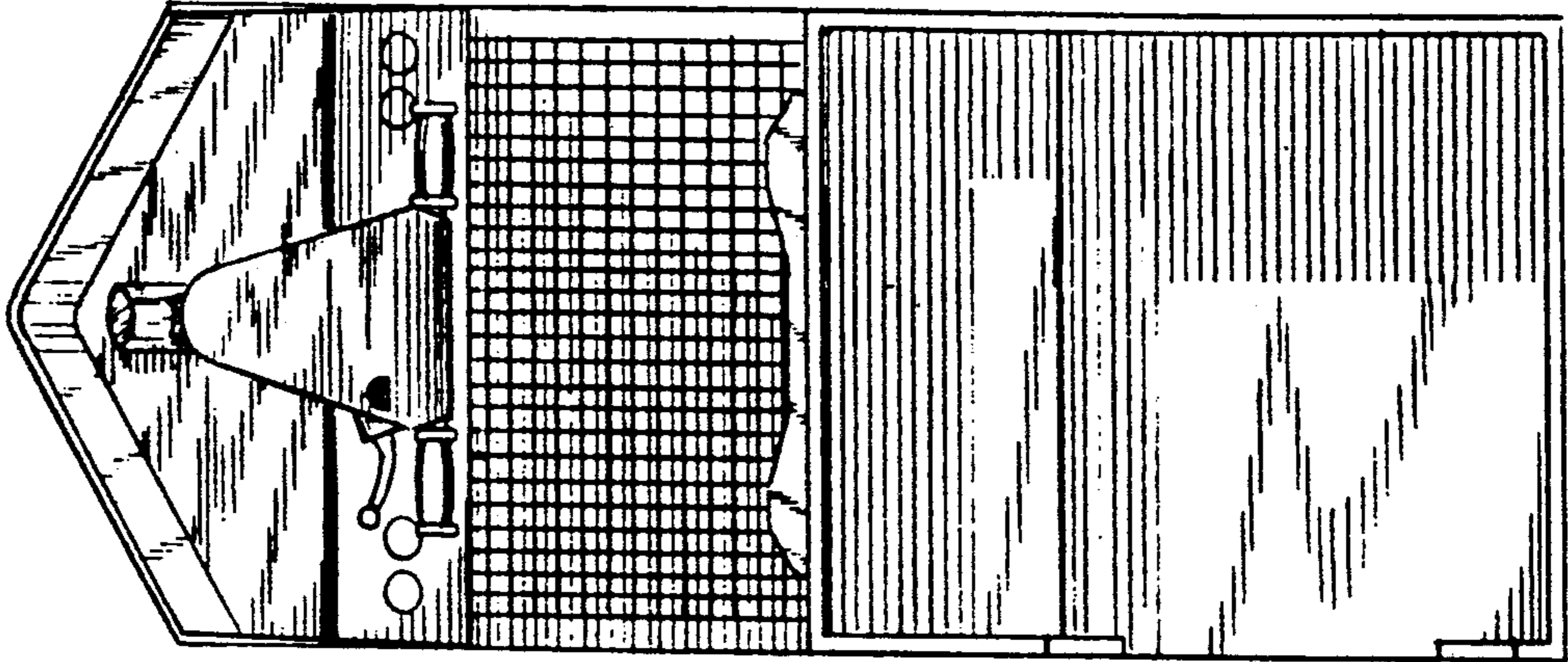

FIG. 9

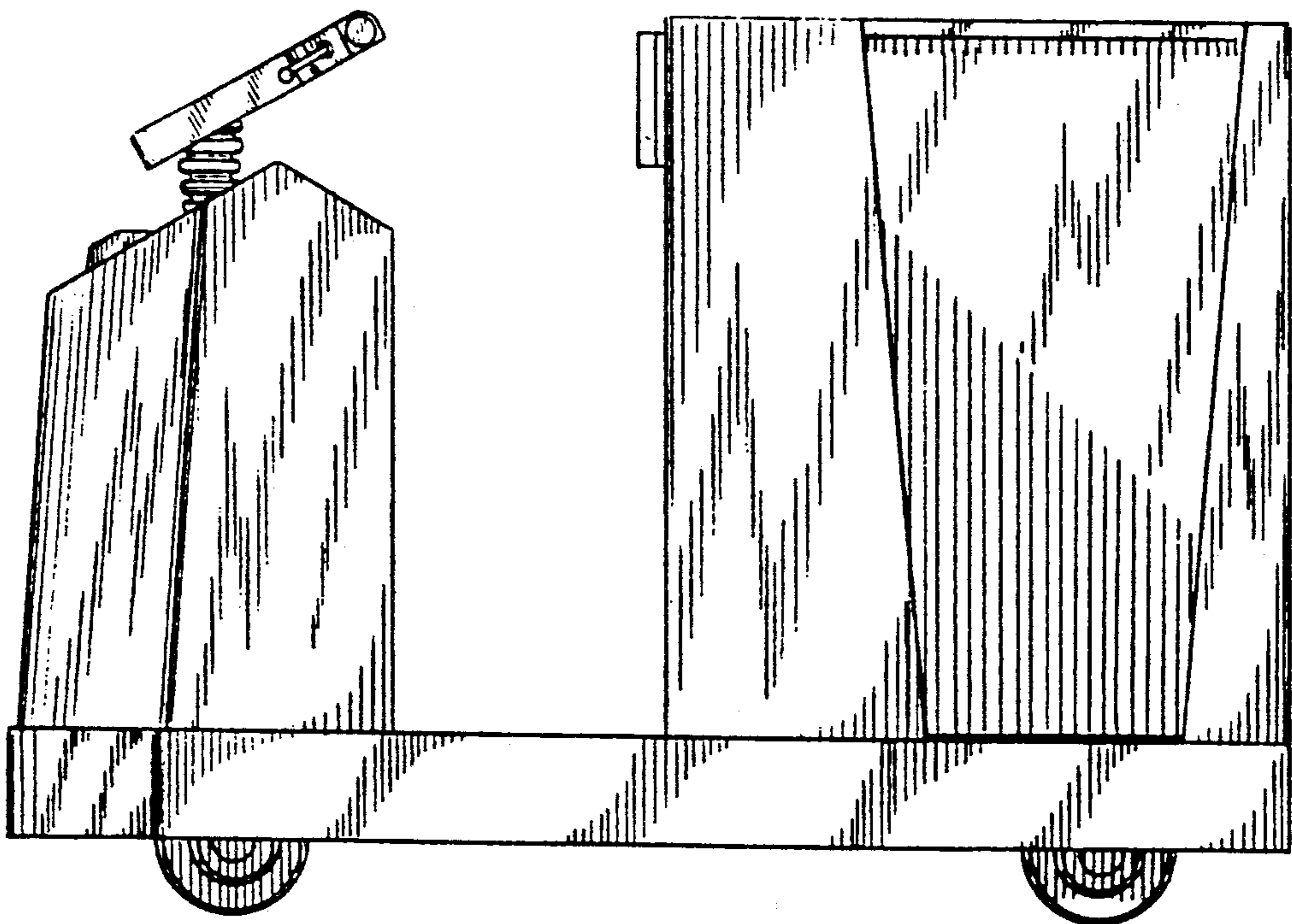

FIG. 10

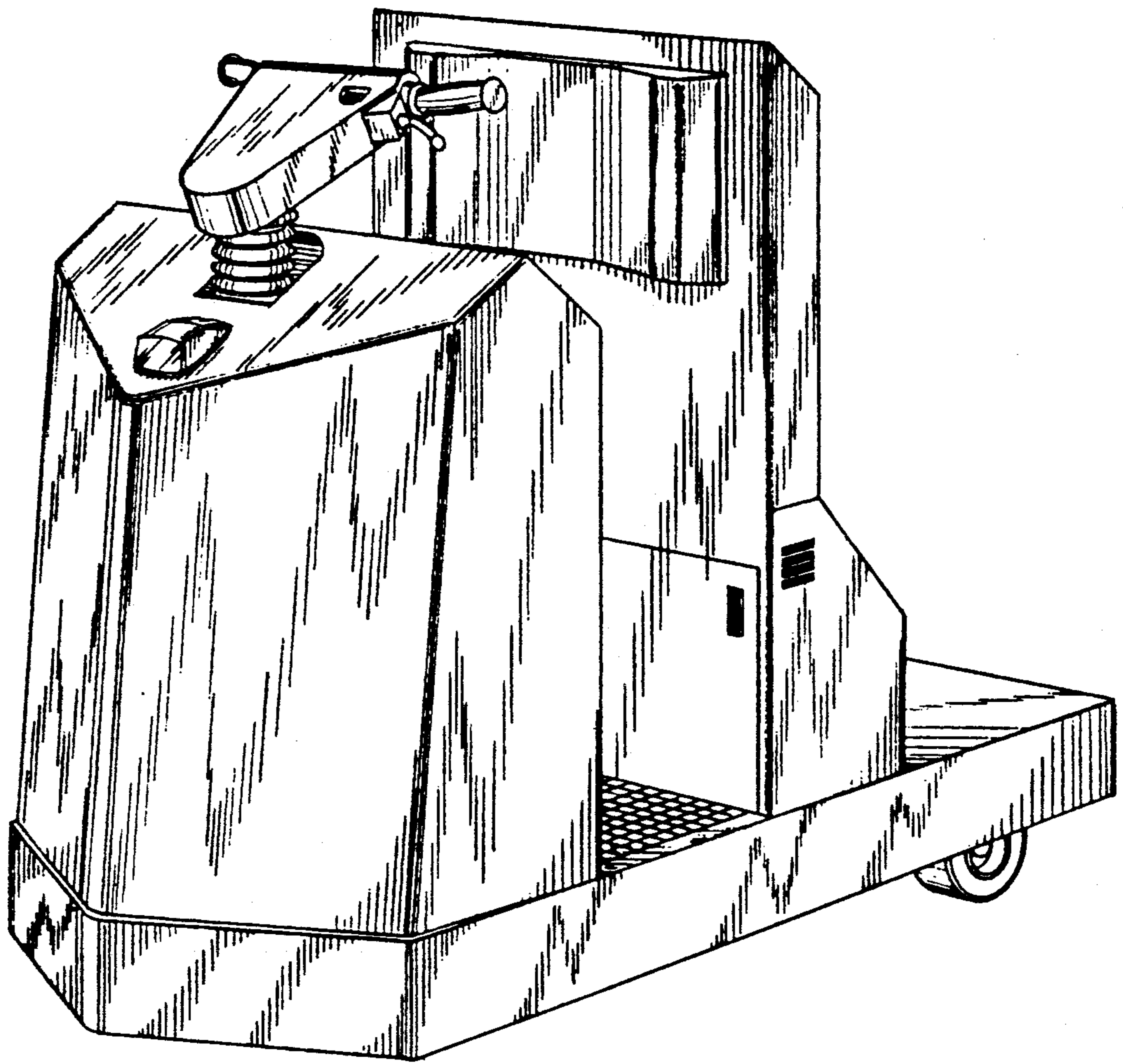

FIG. 11

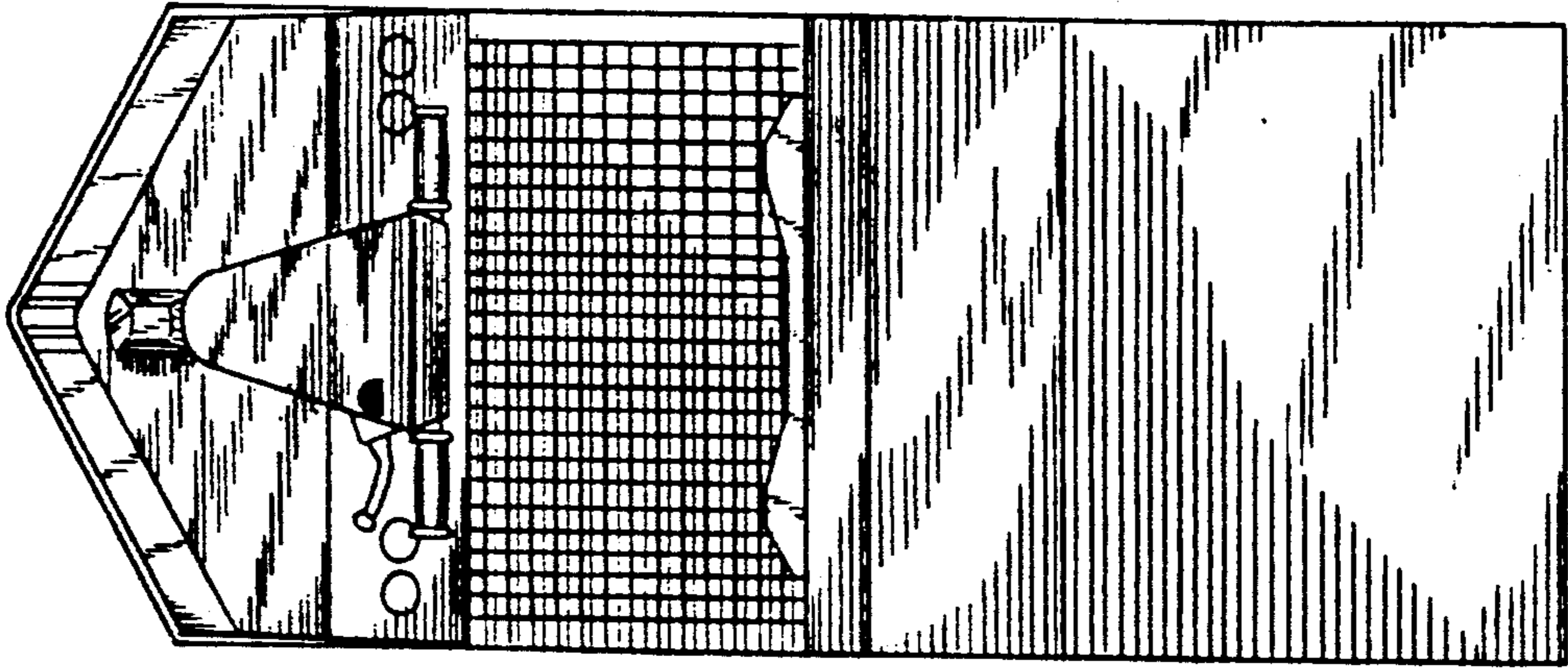

FIG. 12

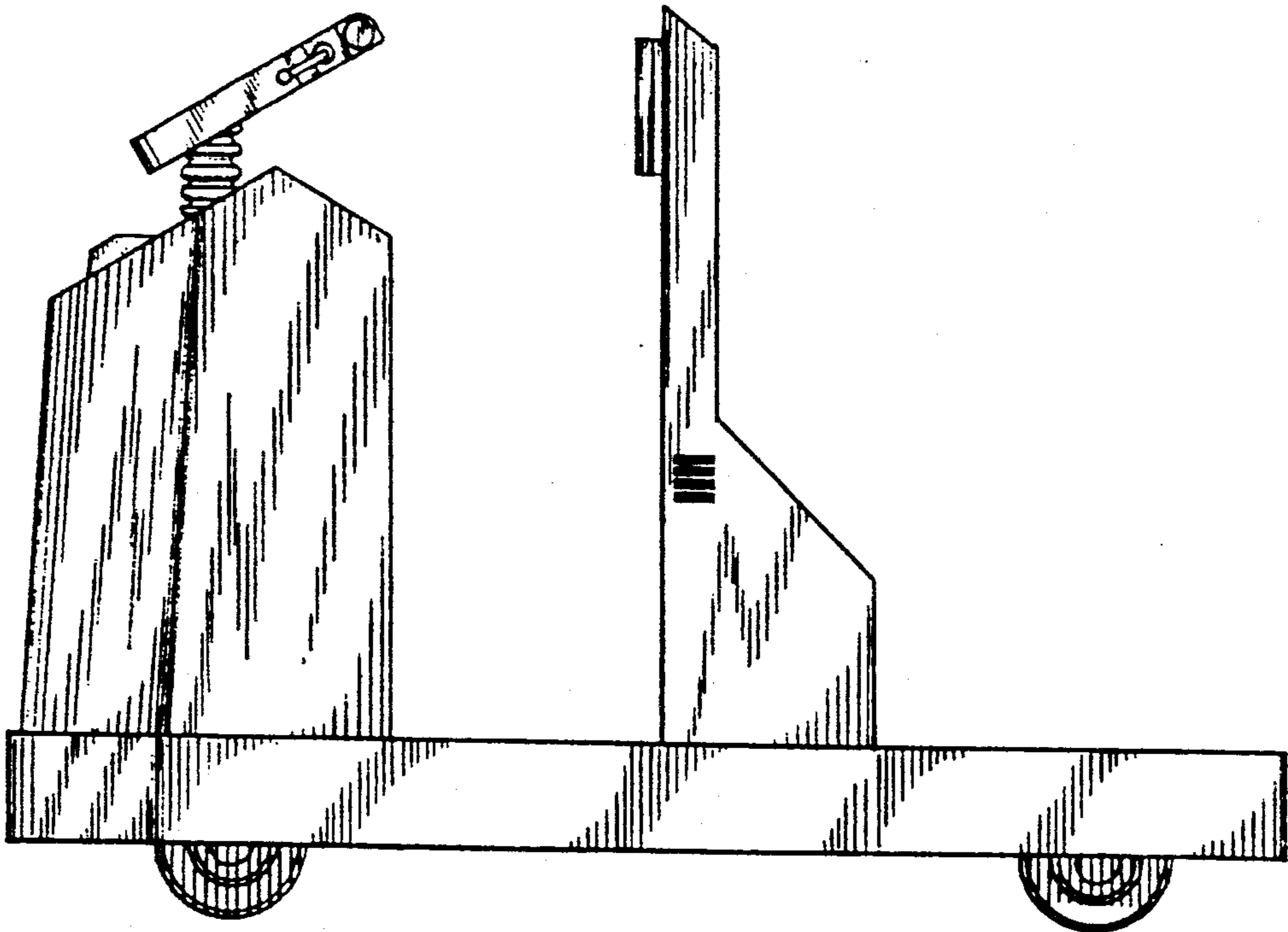

FIG. 13