

[54] CART

[76] Inventor: Boyd G. Ayres, R.R. #1, Wawaka, Ind. 46794

[**] Term: 14 Years

[21] Appl. No.: 208,002

[22] Filed: Jun. 16, 1988

[52] U.S. Cl. D34/26; D34/16

[58] Field of Search D34/12, 16, 24, 25, D34/26; 280/47.26, 47.31, 639, 645, 47.27, 47.28, 47.32

[56] References Cited

U.S. PATENT DOCUMENTS

D. 245,971	10/1977	Martens	D34/16
2,189,079	2/1940	Mueller et al.	280/47.26
3,479,048	11/1969	Carlson	280/47.26
4,335,897	6/1982	Muller, Jr.	280/47.26
4,353,596	10/1982	Gibson	280/47.26

FOREIGN PATENT DOCUMENTS

8903785 5/1989 World Int. Prop. O. 280/47.26

Primary Examiner—Kay H. Chin
Attorney, Agent, or Firm—Lundy and Walker

[57] CLAIM

The ornamental design for a cart, as shown and described.

DESCRIPTION

FIG. 1 is a top plan view of a cart showing my new design;
FIG. 2 is a bottom plan view thereof;
FIG. 3 is a right side elevational view thereof;
FIG. 4 is a front elevational view thereof;
FIG. 5 is a rear elevational view thereof;
FIG. 6 is a left side elevational view thereof;
FIG. 7 is a top perspective view thereof, the wheels removed and a portion of the side wall of the cart shown broken away for clarity of illustration; and
FIG. 8 is a bottom perspective view thereof, with the wheels removed.

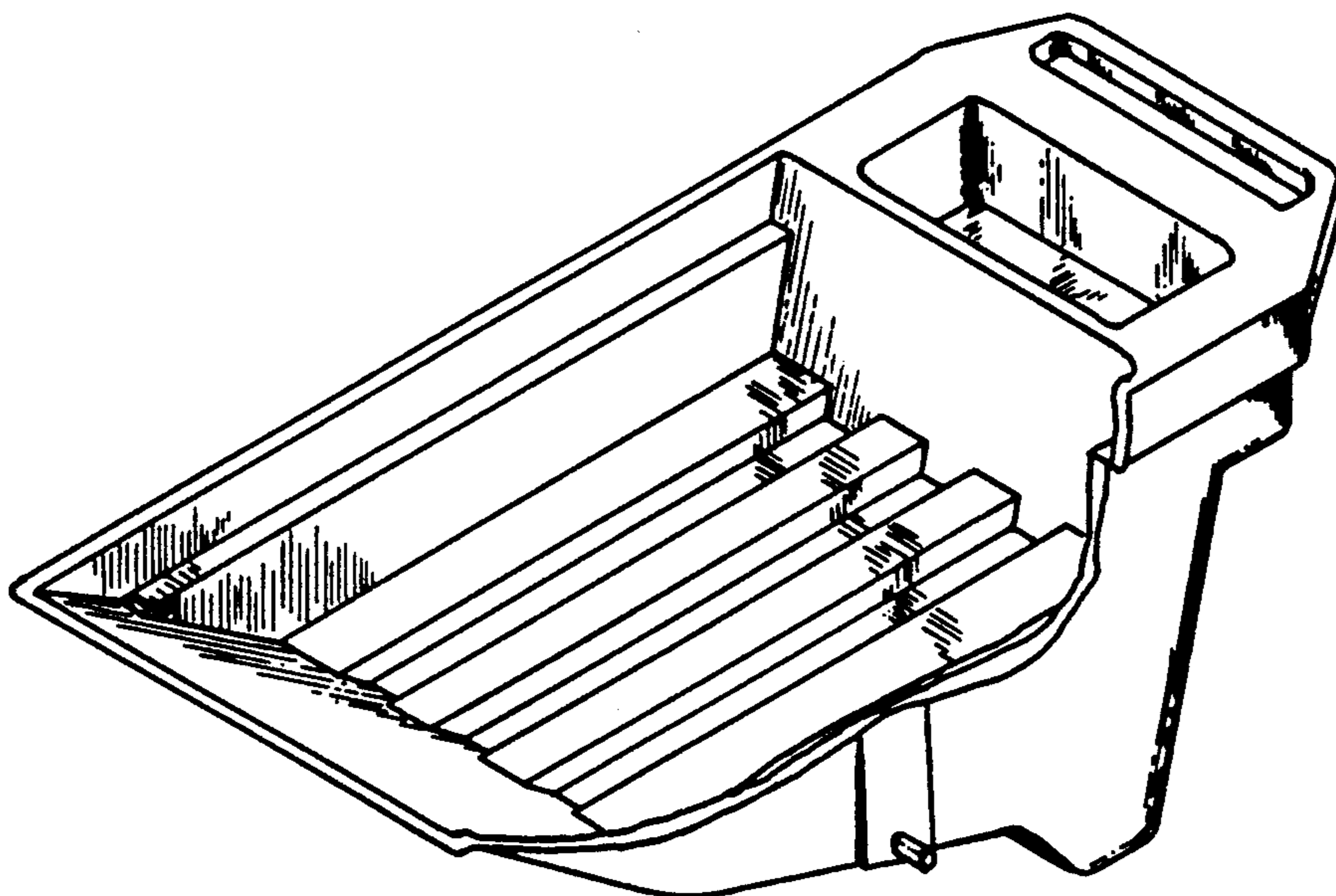
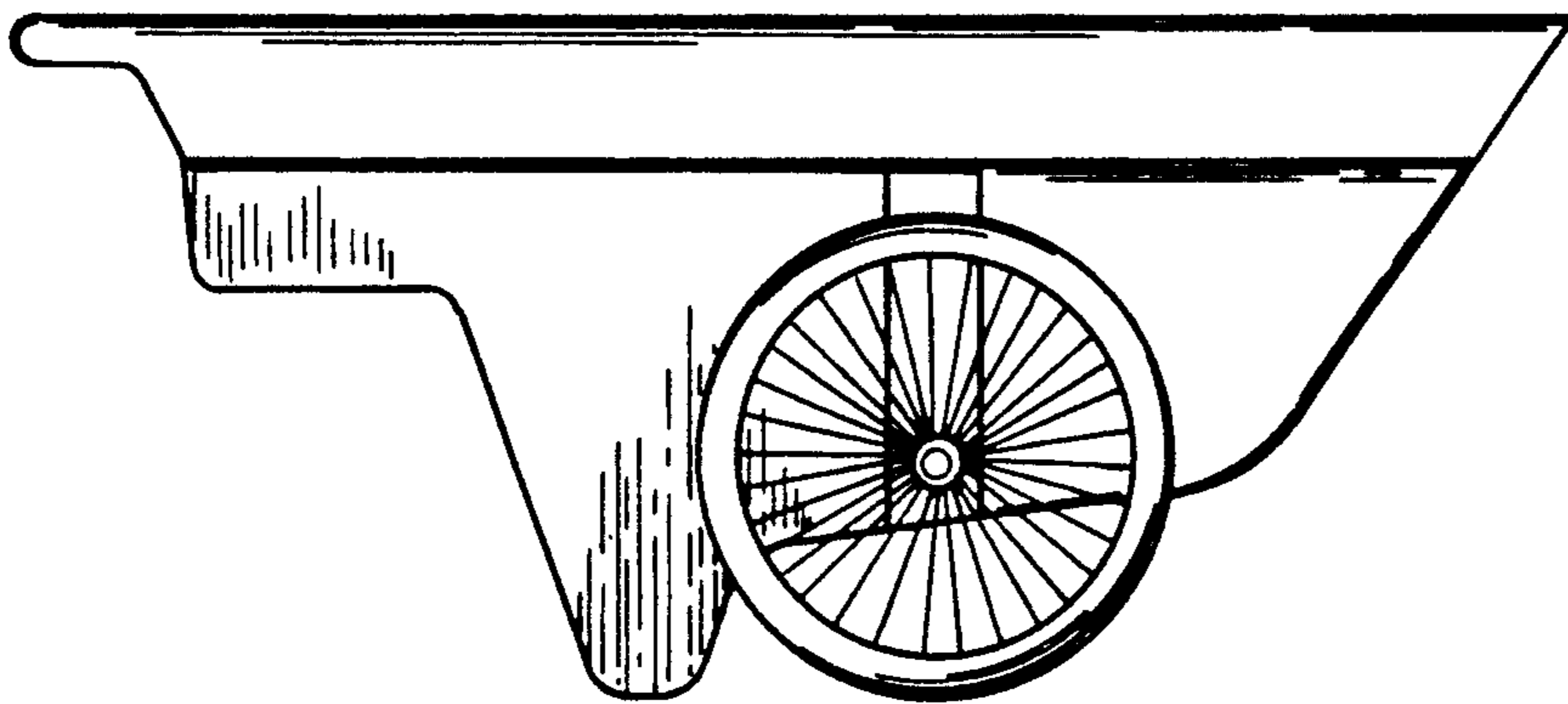

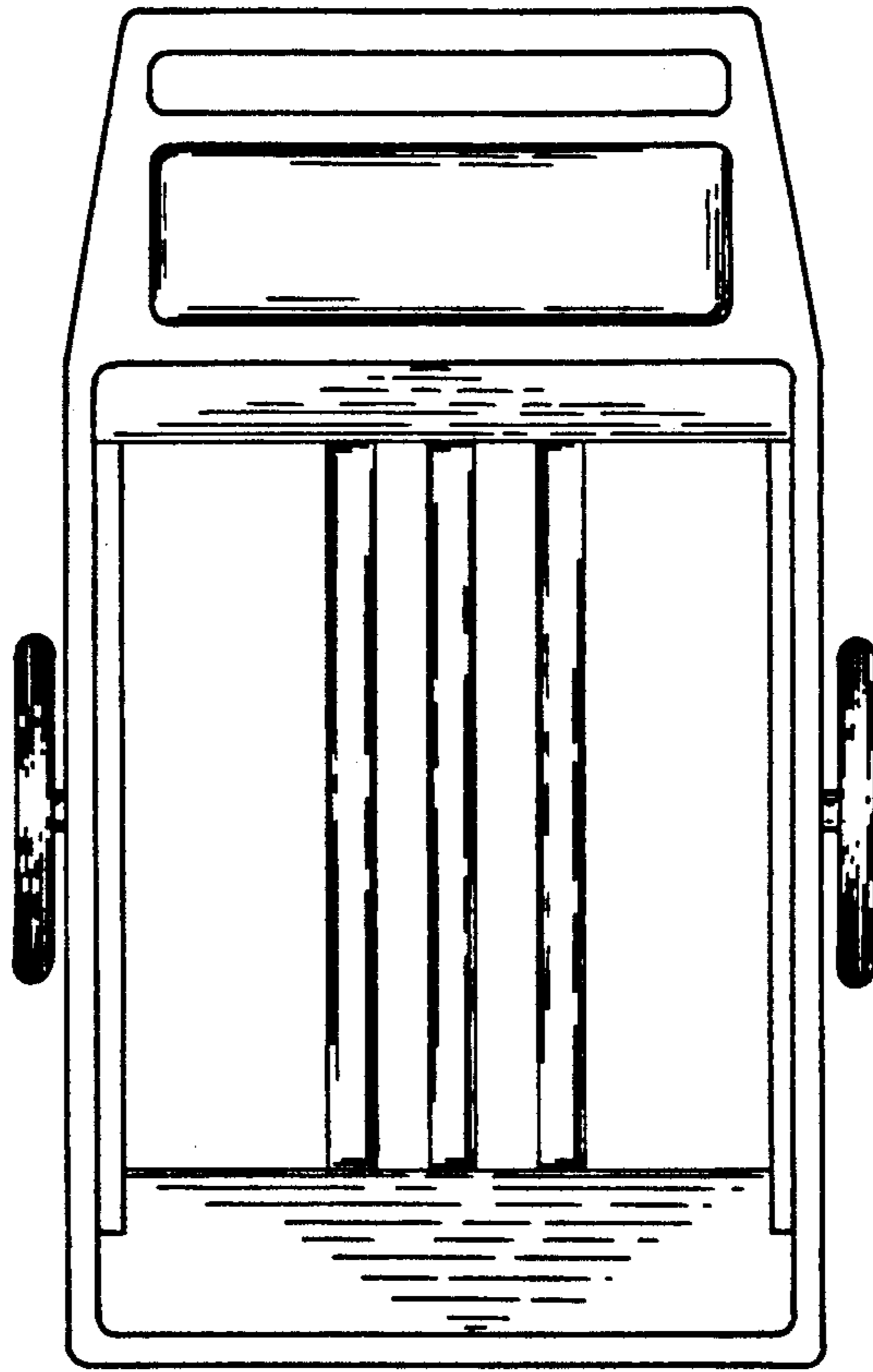

FIG. 1

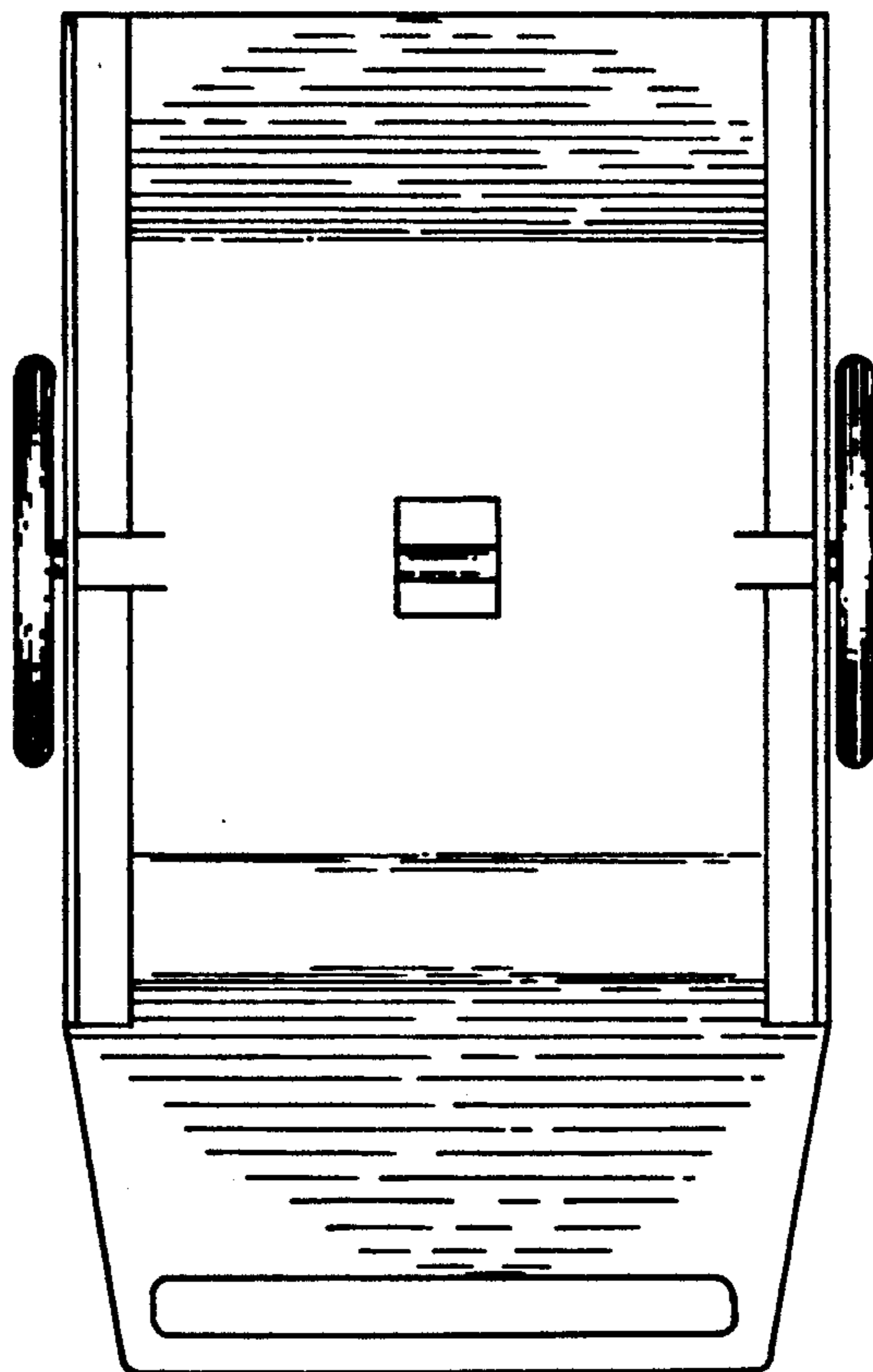

FIG. 2

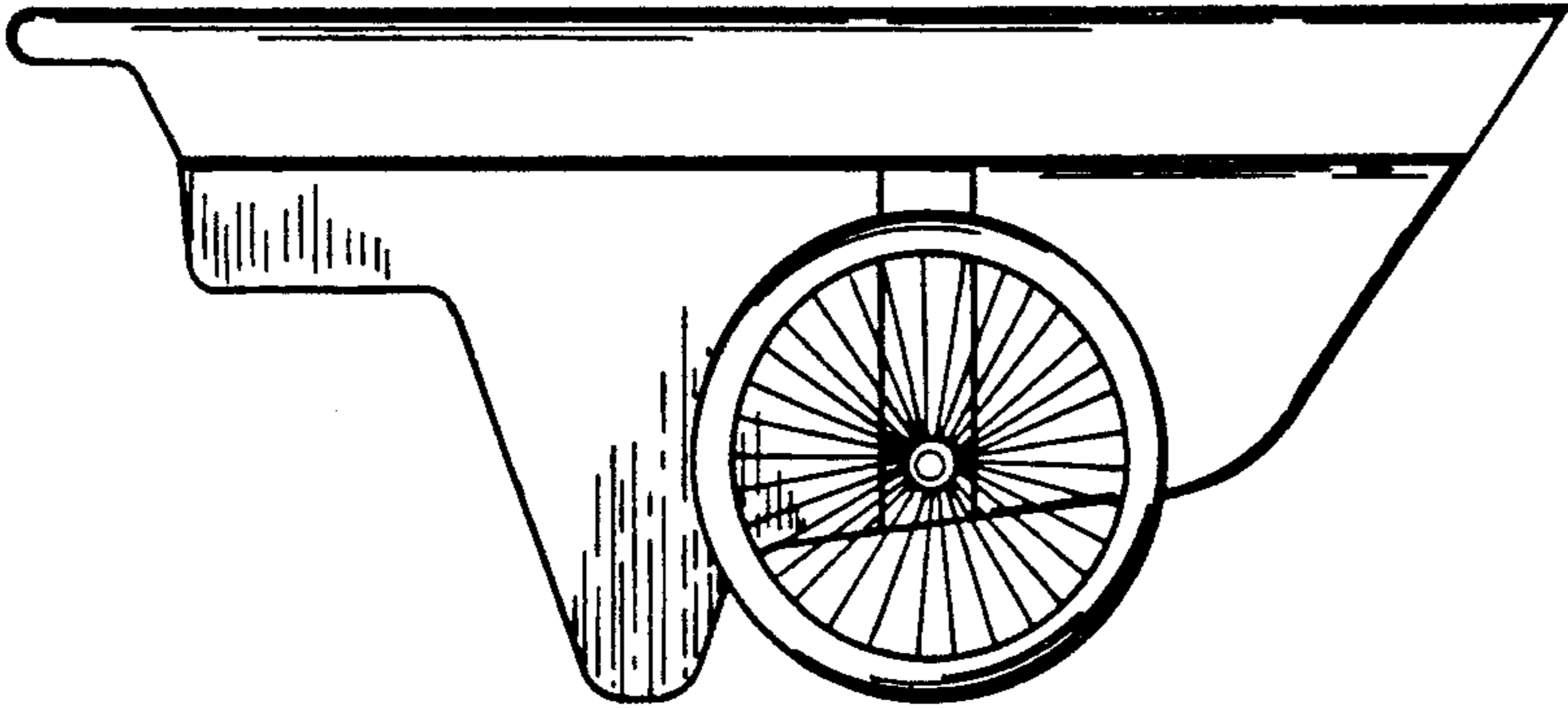

FIG. 3

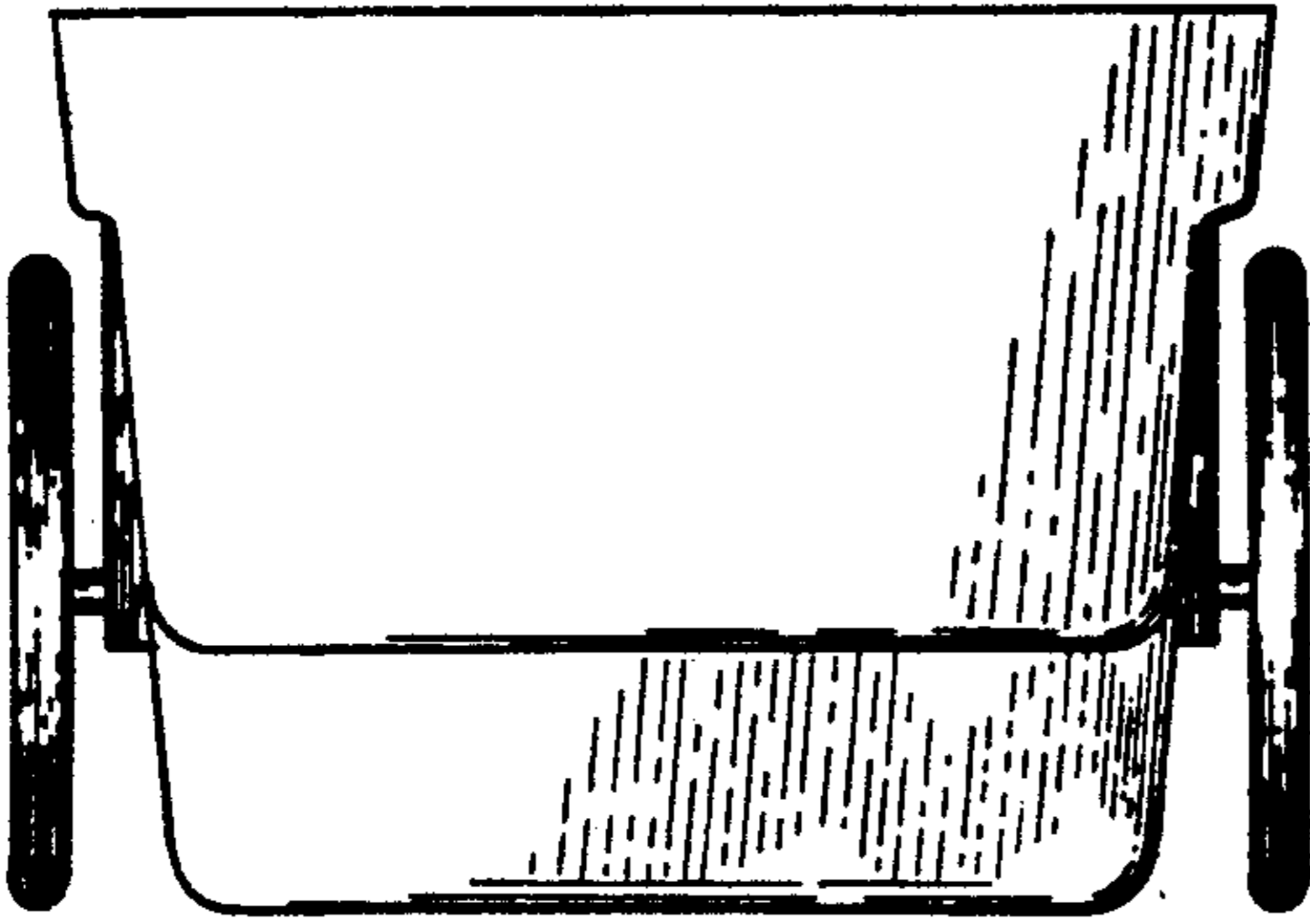

FIG. 4

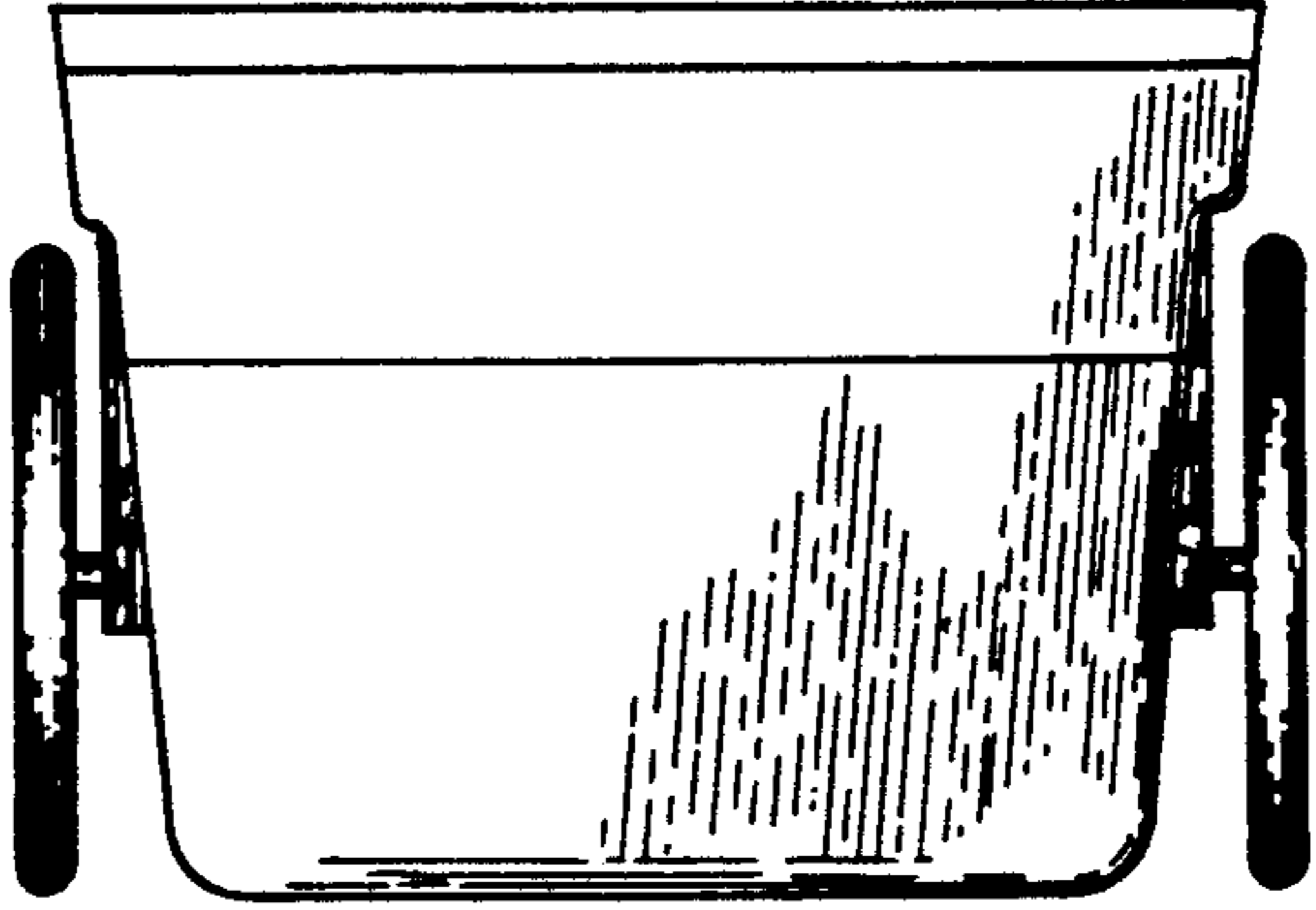

FIG. 5

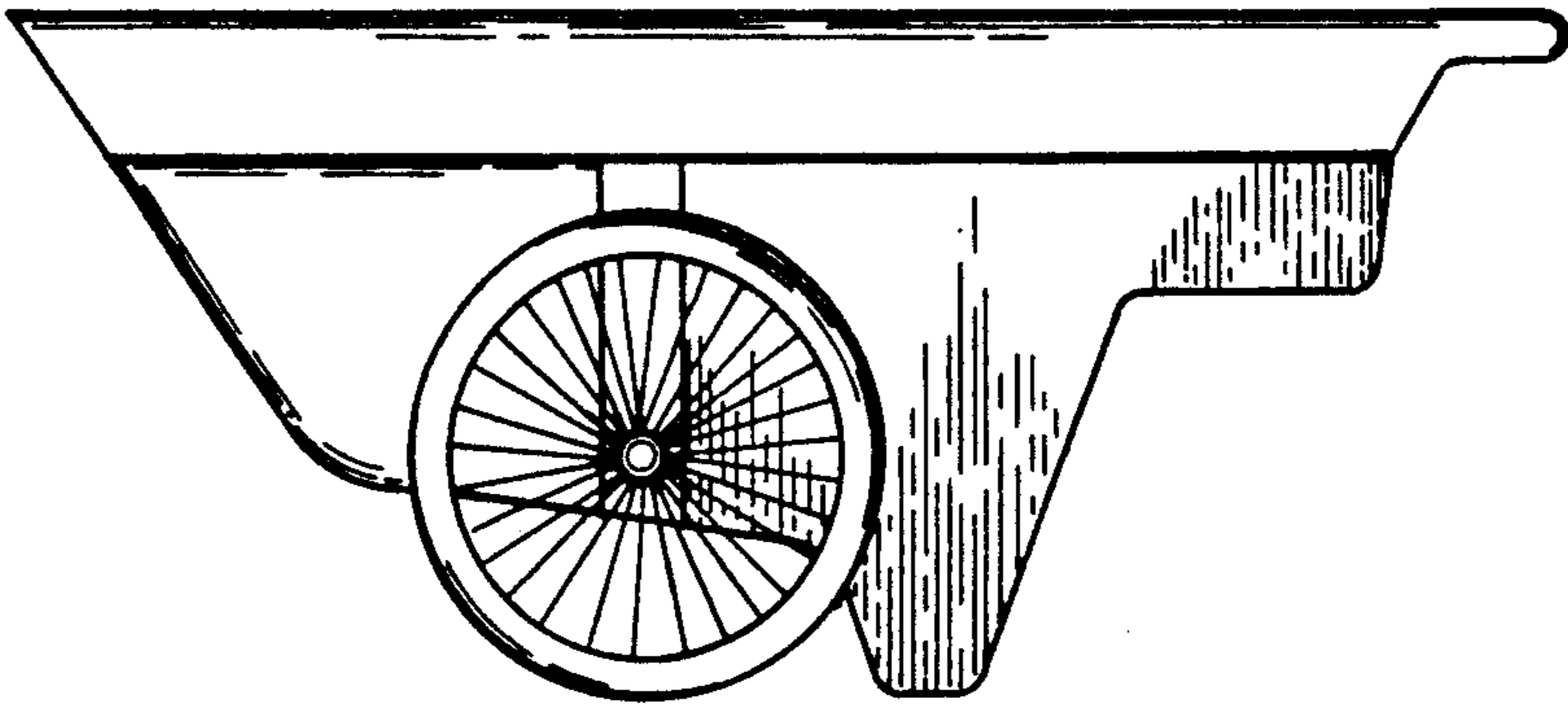

FIG. 6

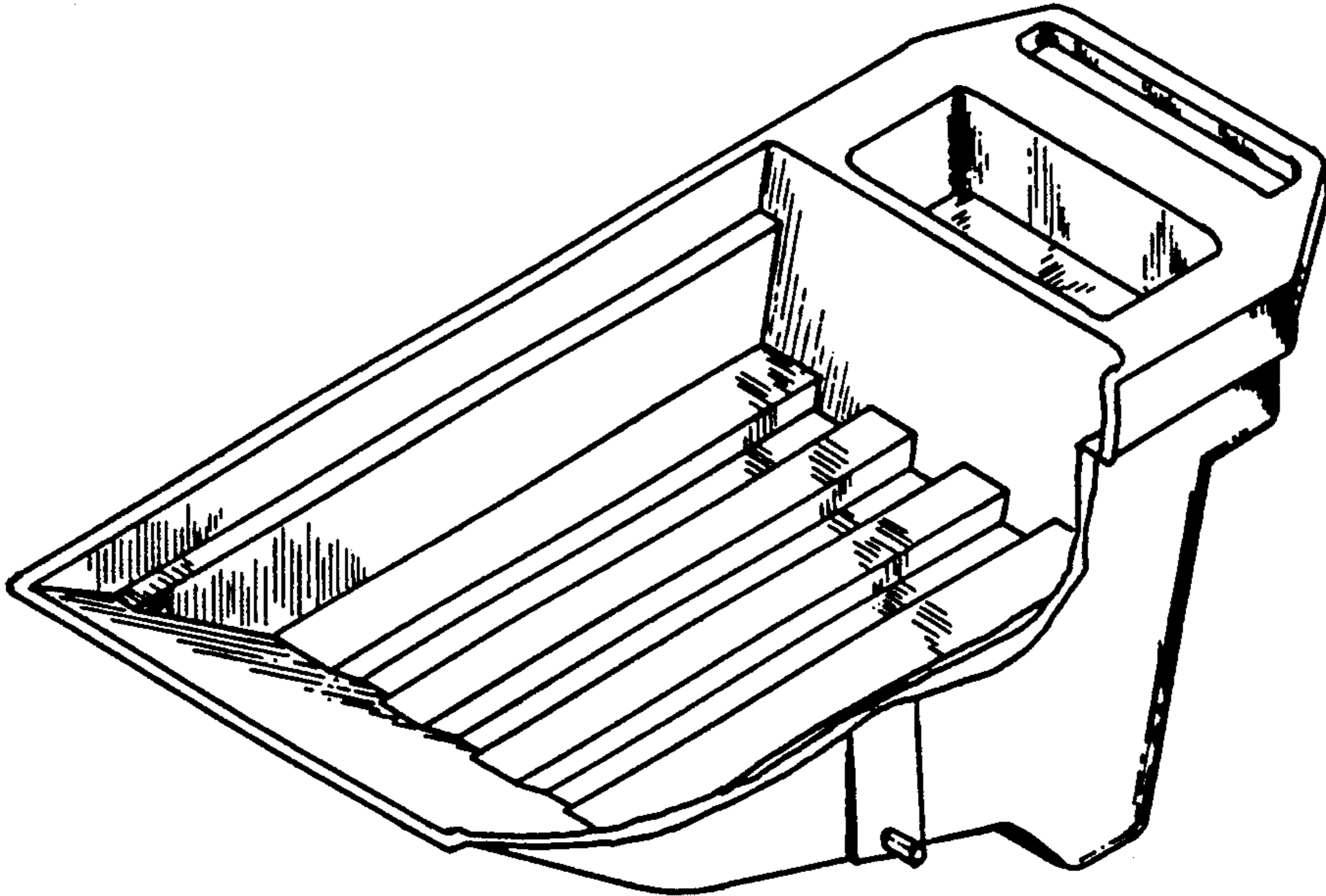

FIG. 7

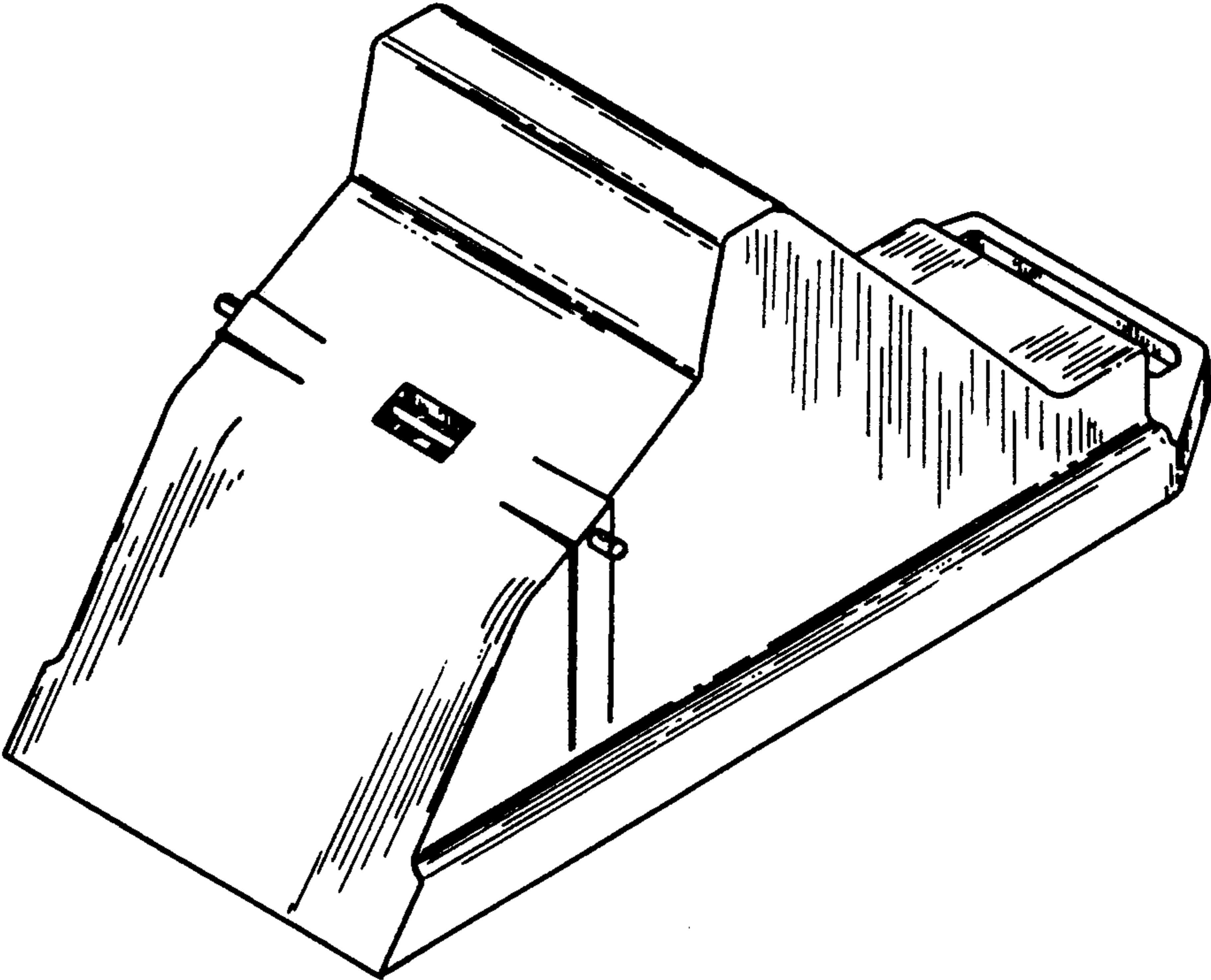

FIG. 8