

[54] STEERING WHEEL FOR BOATS

[76] Inventor: Warwick M. Whitley, II, 2205 Trinity St., Lynn Haven, Fla. 32444

[**] Term: 14 Years

[21] Appl. No.: 348,477

[22] Filed: May 8, 1989

Related U.S. Application Data

[63] Continuation-in-part of Ser. No. 231,386, Aug. 12, 1988, Pat. No. Des. 311,369.

[52] U.S. Cl. D12/176

[58] Field of Search D12/176, 175; 74/552

[56] References Cited

U.S. PATENT DOCUMENTS

| | | | |
|------------|---------|-----------------------|---------|
| D. 264,957 | 6/1982 | Schinella et al. | D12/176 |
| D. 295,846 | 5/1988 | Whitley, II | D12/176 |
| D. 296,428 | 6/1988 | Faul | D12/176 |
| D. 301,224 | 5/1989 | Funabashi et al. | D12/176 |
| D. 311,369 | 10/1990 | Whitley, II | D12/176 |
| D. 312,435 | 11/1990 | Funabashi et al. | D12/176 |

FOREIGN PATENT DOCUMENTS

3827794 3/1989 Fed. Rep. of Germany 74/552

OTHER PUBLICATIONS

Page 81 of Attwood's Product Catalog 1987-88.
Pages 65-66 of Attwood's Product Catalog 1985-86.
Pages 50-51 of Attwood's Product Catalog 1983-84.

Primary Examiner—James M. Gandy
Attorney, Agent, or Firm—Price, Heneveld, Cooper,
DeWitt & Litton

[57] CLAIM

The ornamental design for a steering wheel for boats, as shown and described.

DESCRIPTION

FIG. 1 is a front perspective view of a steering wheel for boats showing my new design;
FIG. 2 is a top plan view thereof;
FIG. 3 is a rear elevation view thereof;
FIG. 4 is a front elevation view thereof;
FIG. 5 is a side elevation view thereof, the opposite side being a mirror image of that shown;
FIG. 6 is a bottom plan view thereof;
FIG. 7 is a front perspective view thereof with the center cap removed;
FIG. 8 is a top plan view of FIG. 7;
FIG. 9 is a rear elevation view of FIG. 7;
FIG. 10 is a front elevation view of FIG. 7; and
FIG. 11 is a side elevation view of FIG. 7, the opposite side being a mirror image of that shown.

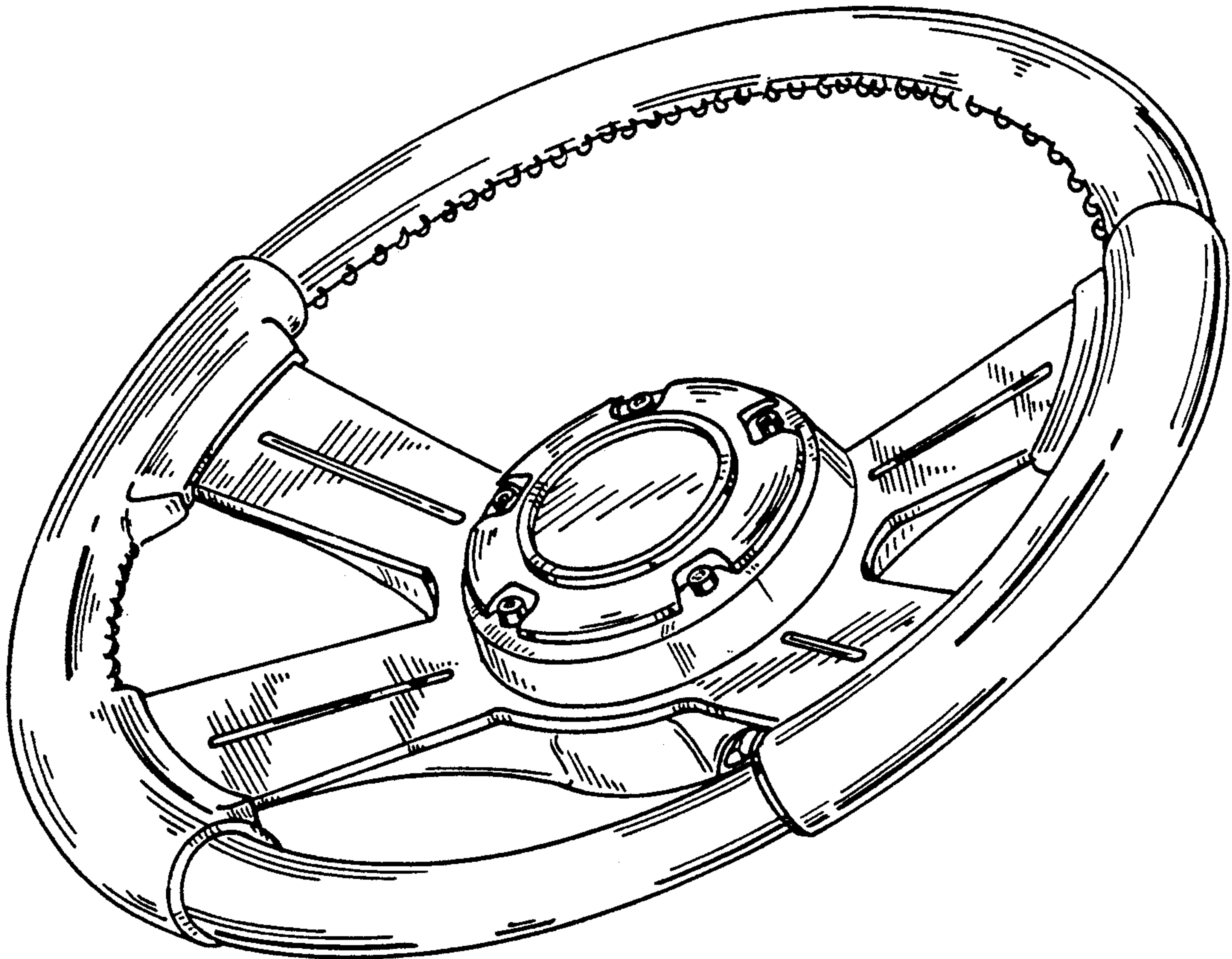

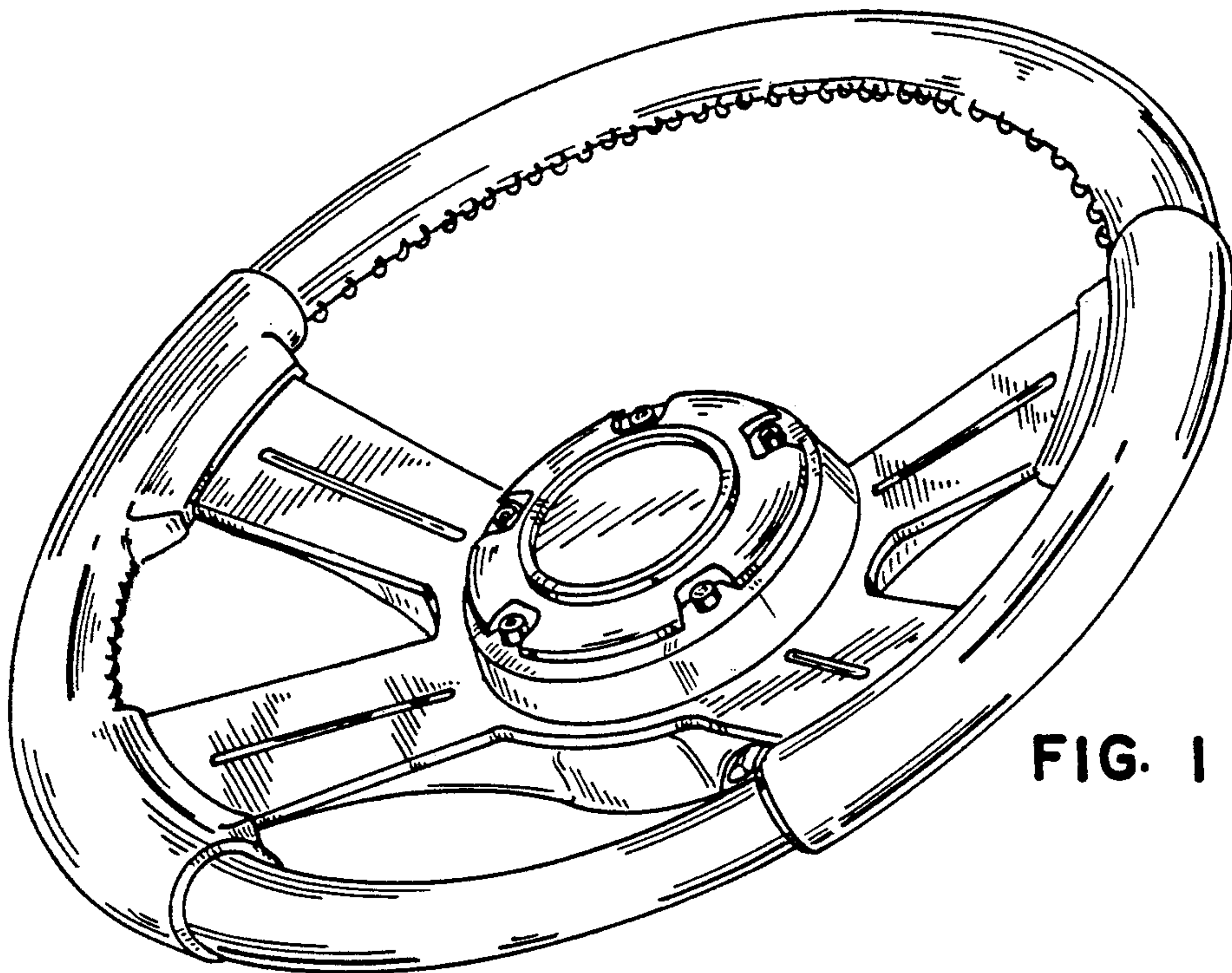

FIG. 1

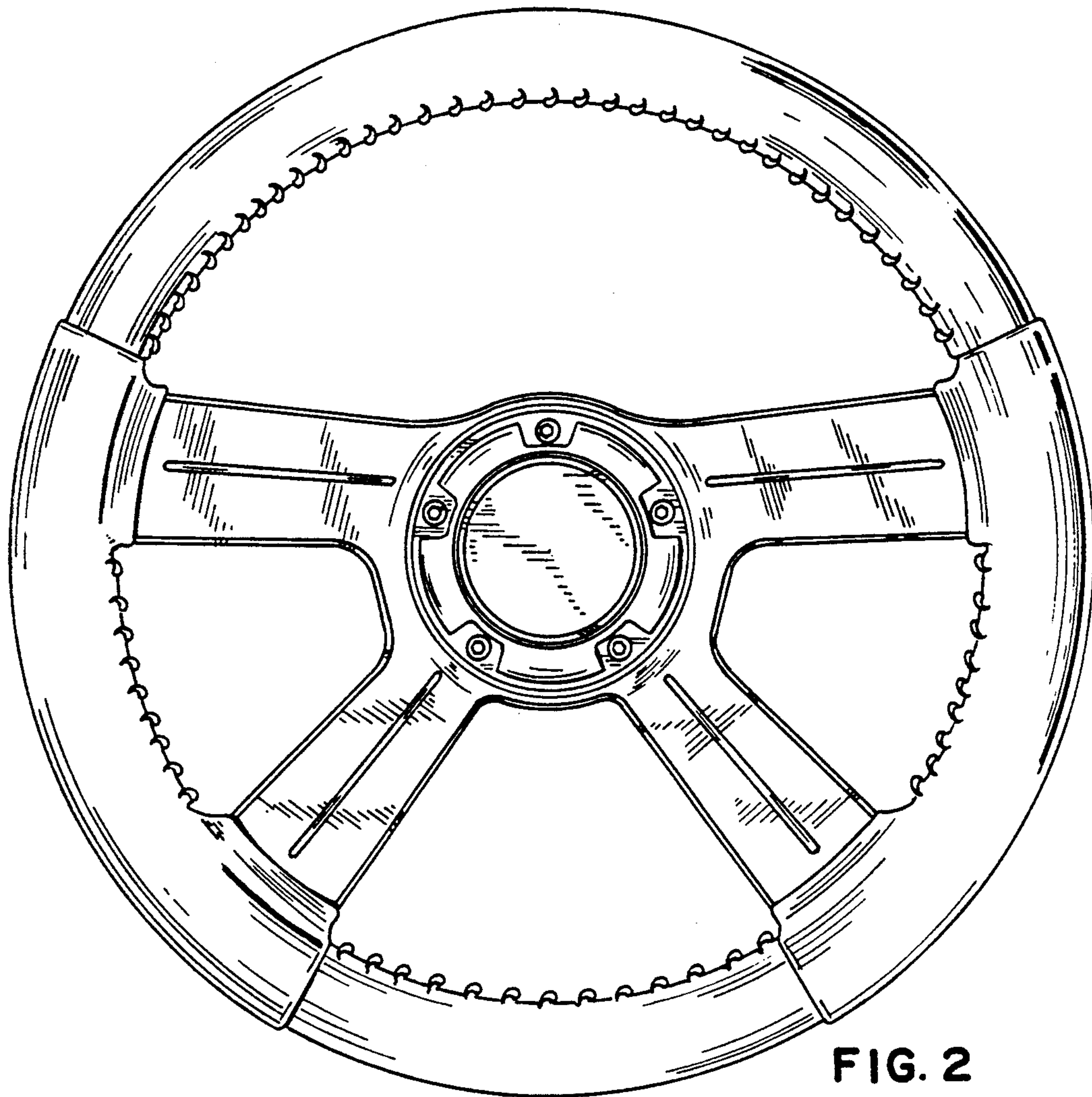

FIG. 2

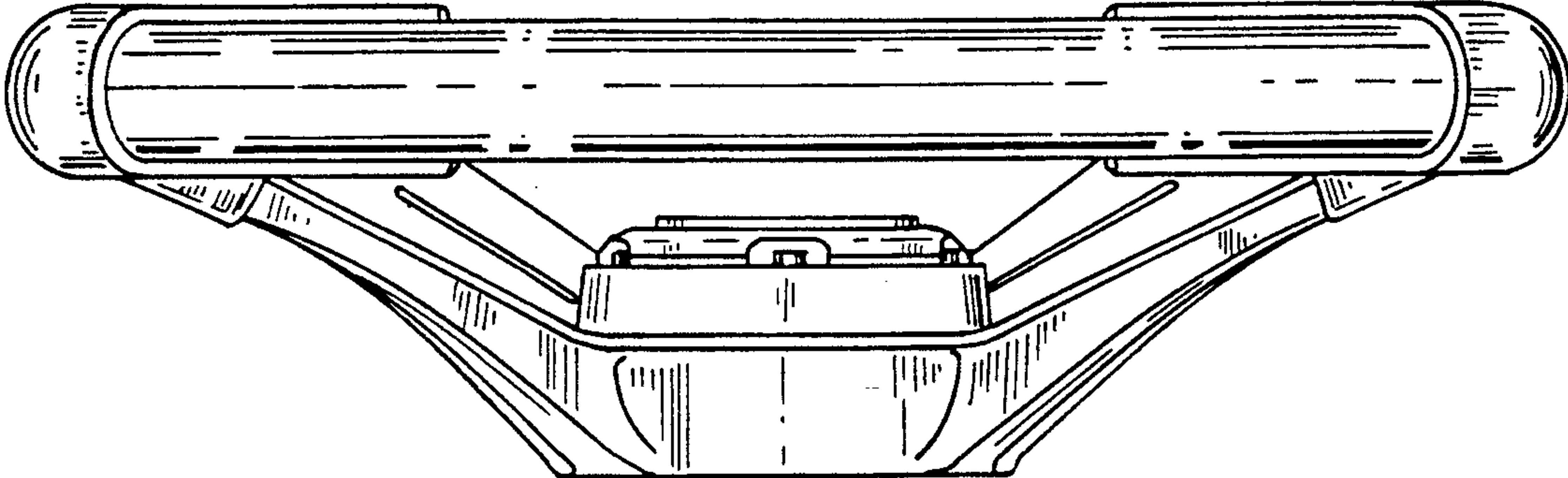

FIG. 3

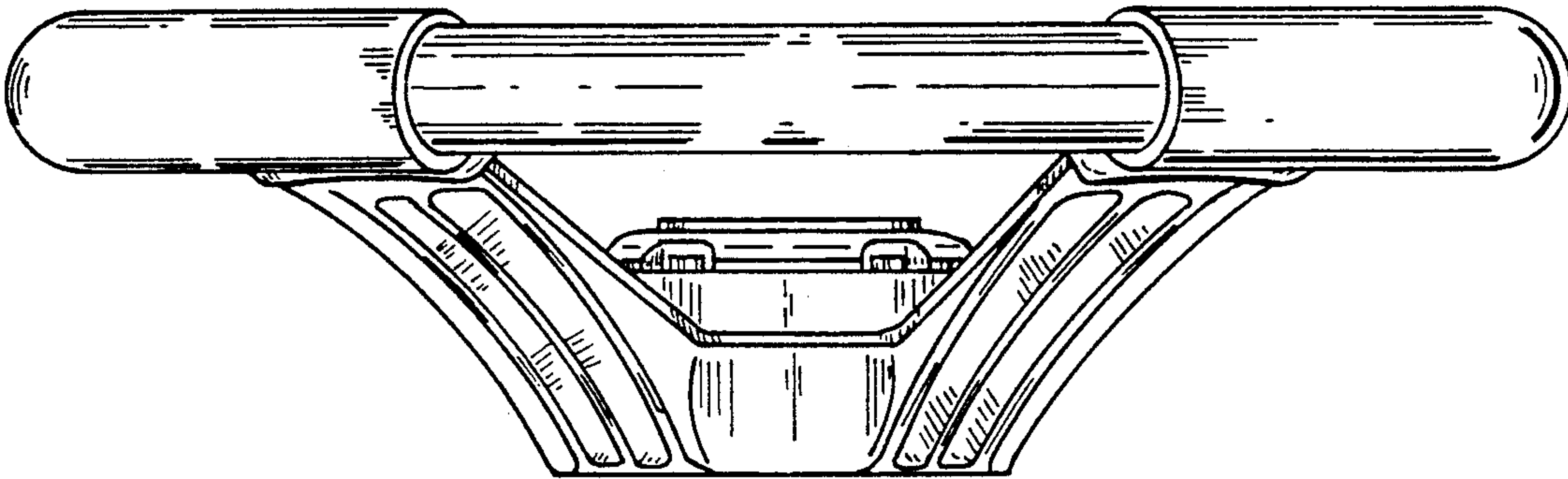

FIG. 4

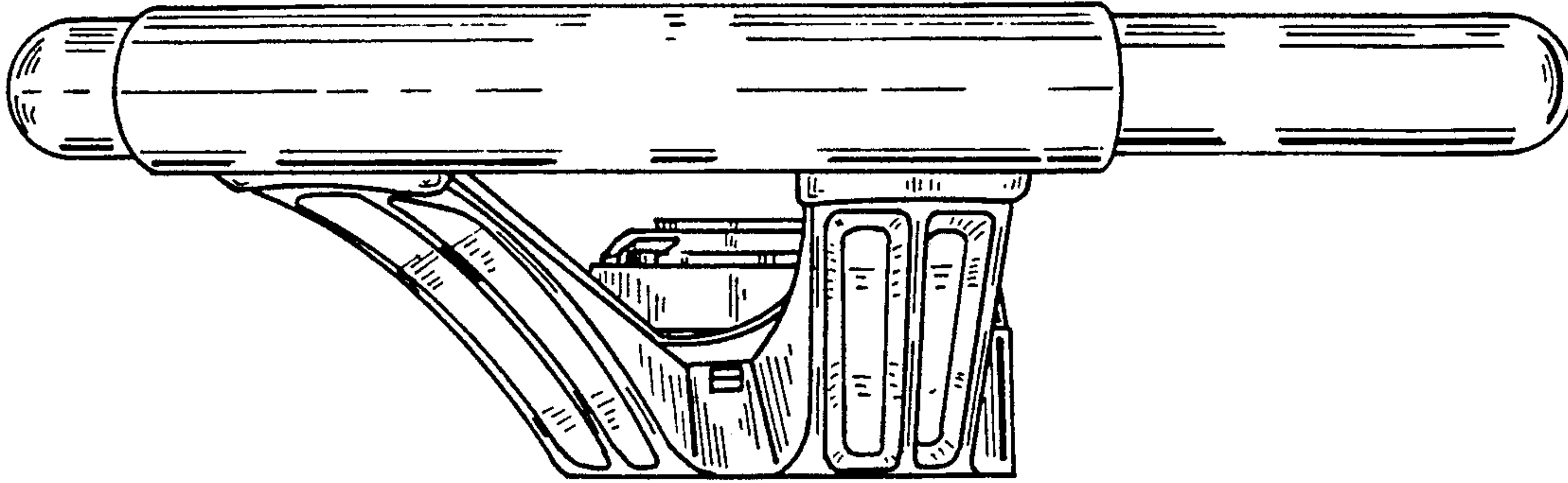

FIG. 5

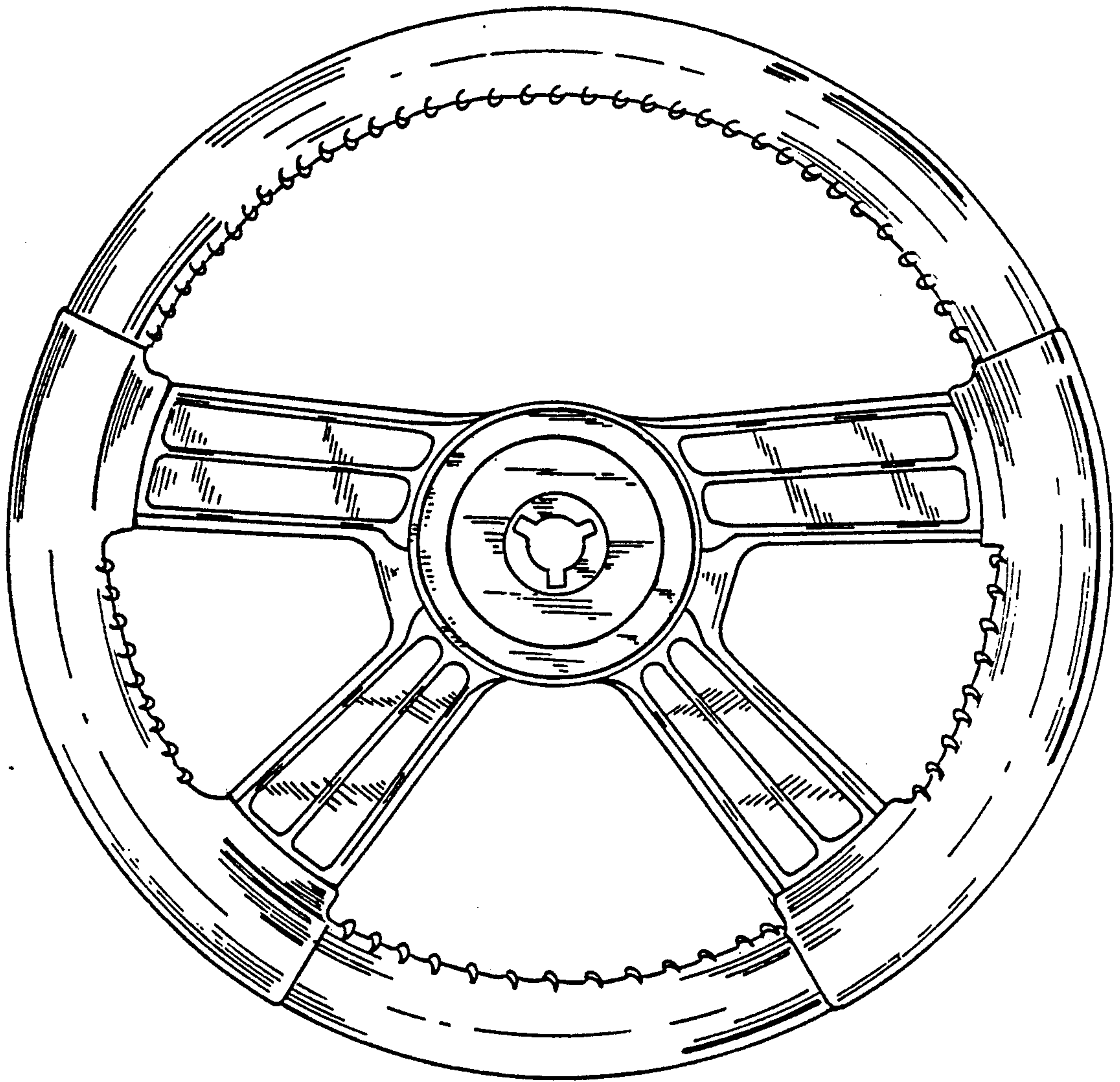

FIG. 6

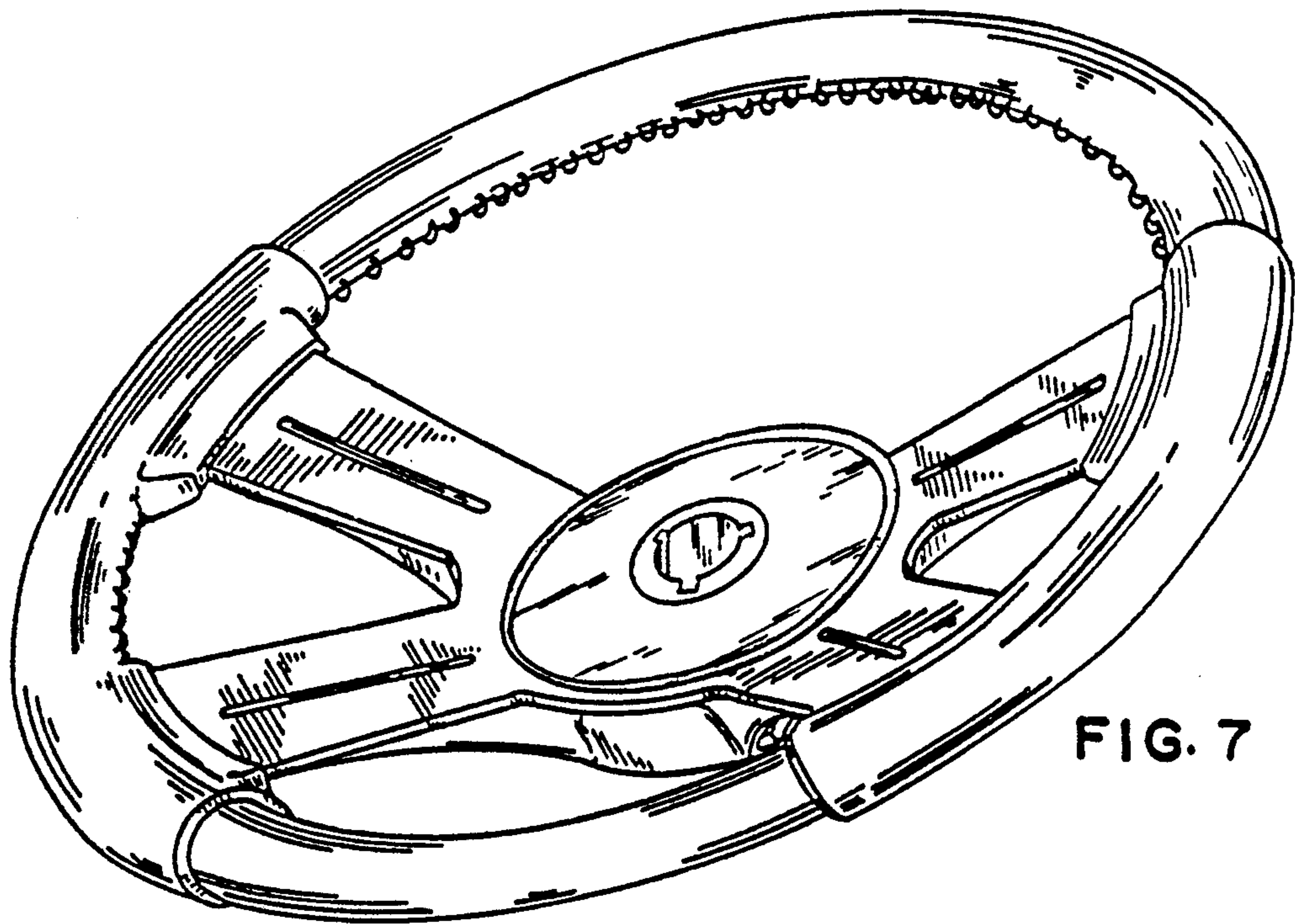

FIG. 7

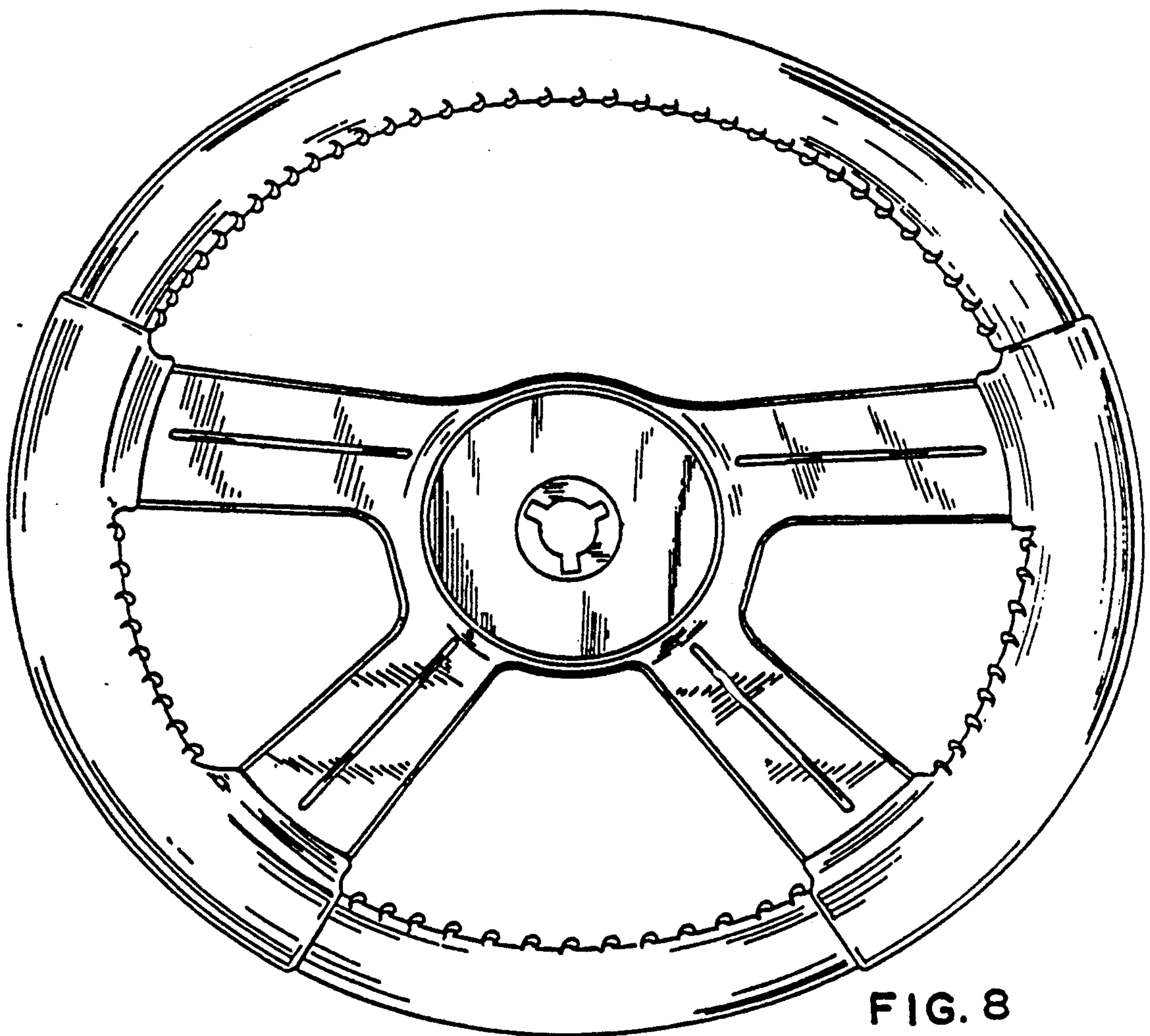

FIG. 8

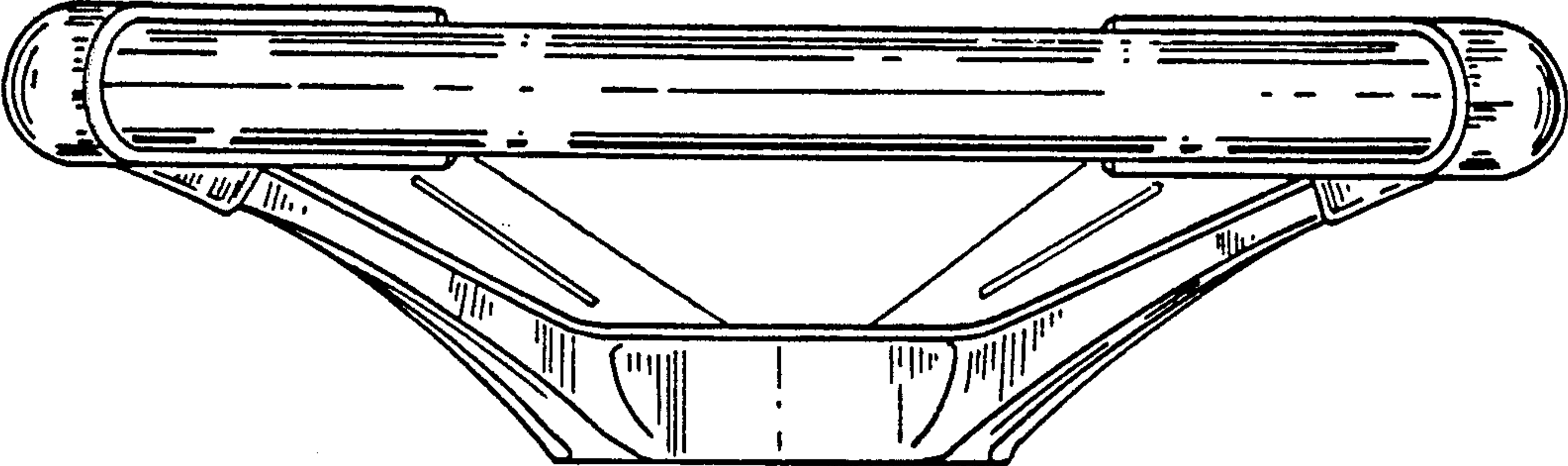

FIG. 9

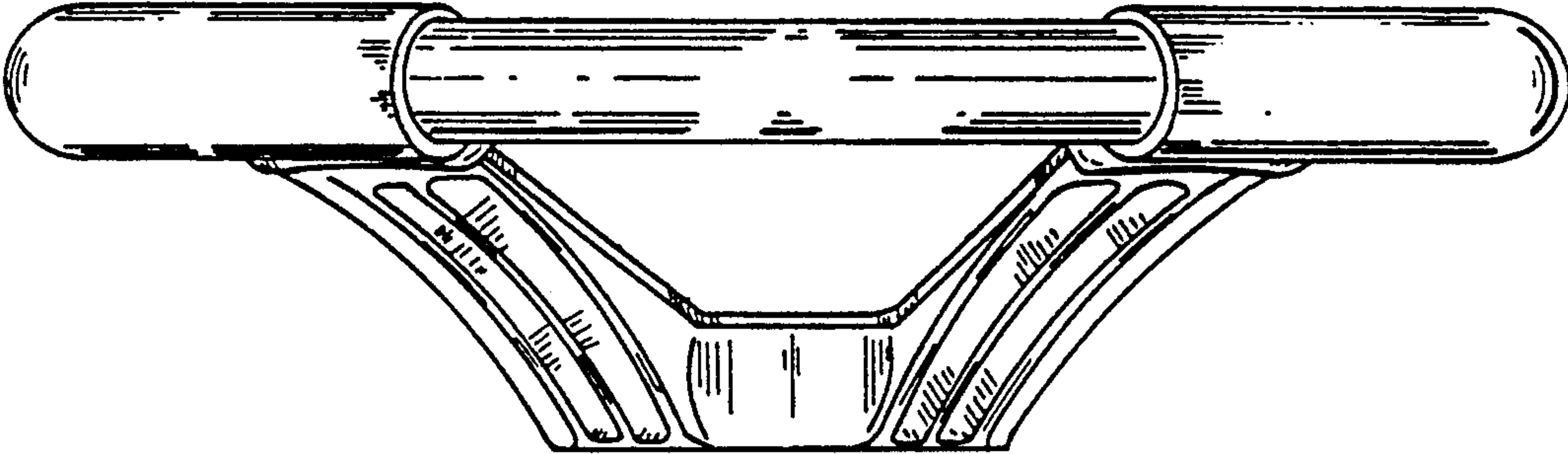

FIG. 10

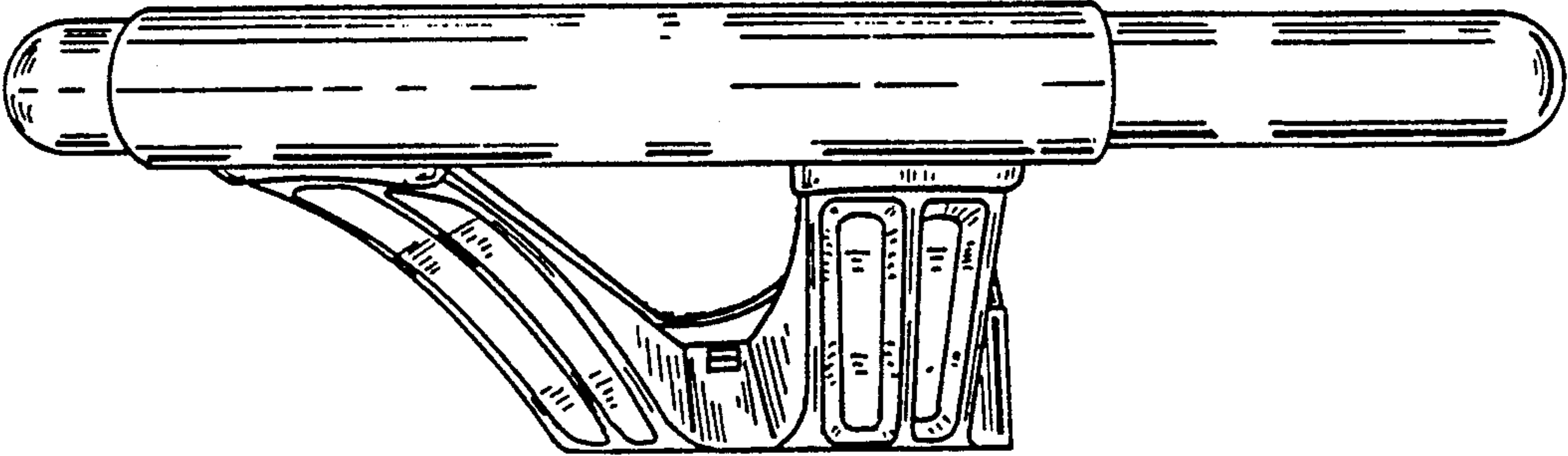

FIG. 11