

[54] CROSSBAR SUPPORT FOR AN ARTICLE CARRIER

[75] Inventors: Jon D. Sparham, Pontiac; Alan D. Lusky; Thomas C. Nanney, both of Warren, all of Mich.

[73] Assignee: Huron/St. Clair Incorporated, Taylor, Mich.

[**] Term: 14 Years

[21] Appl. No.: 388,223

[22] Filed: Aug. 1, 1989

Related U.S. Application Data

[63] Continuation-in-part of Ser. No. 250,705, Sep. 28, 1988.
[52] U.S. Cl. D12/157
[58] Field of Search D12/157; 224/309, 321, 224/324-327

[56] References Cited

U.S. PATENT DOCUMENTS

D. 255,344 6/1980 Ingram D12/157
D. 266,836 11/1982 Ingram D12/157
D. 267,247 12/1982 Kowalski et al. D12/157
4,618,082 10/1986 Bell 224/326

Primary Examiner—James M. Gandy
Attorney, Agent, or Firm—Leon E. Redman; Malcolm L. Sutherland; Edgar A. Zarins

[57] CLAIM

The ornamental design for a crossbar support for an article carrier, as shown and described.

DESCRIPTION

FIG. 1 is a perspective view of a crossbar support for an article carrier showing our new design; FIG. 2 is a top plan view thereof; FIG. 3 is a front elevation view thereof; FIG. 4 is a right side elevation view thereof; FIG. 5 is a left side elevation view thereof; and FIG. 6 is a bottom plan view thereof. The broken lines are for illustrative purposes only and form no part of the claimed design.

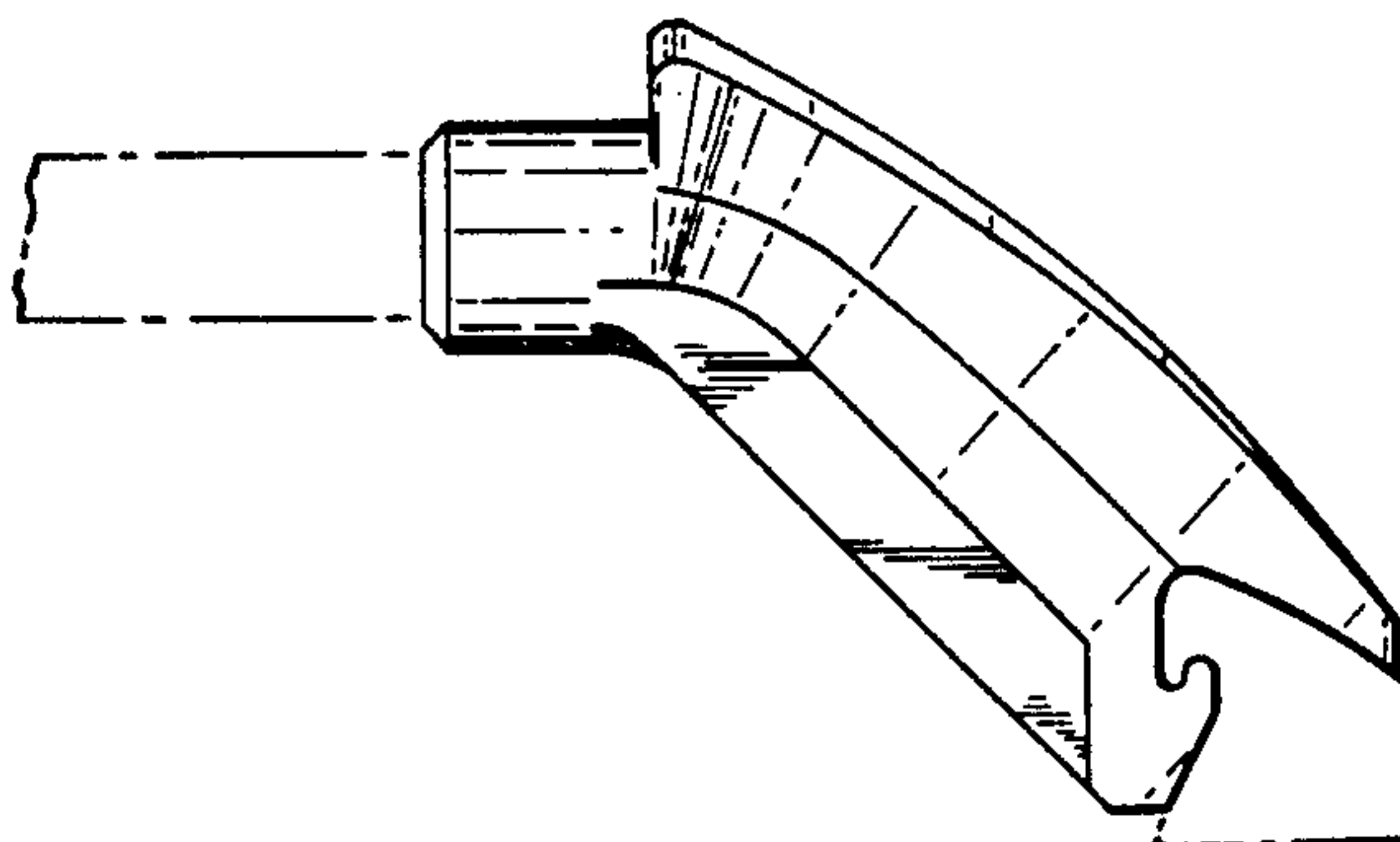
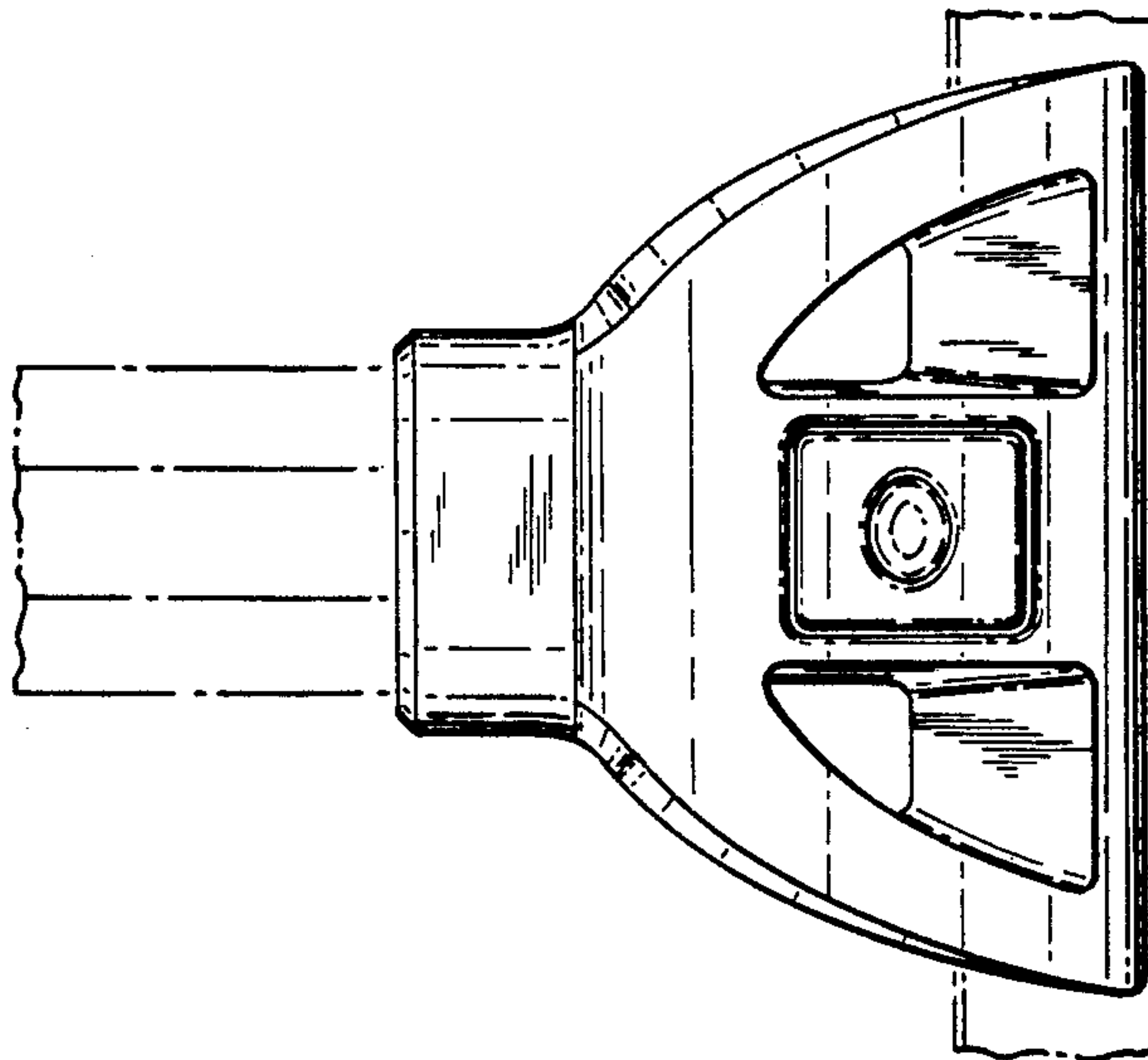

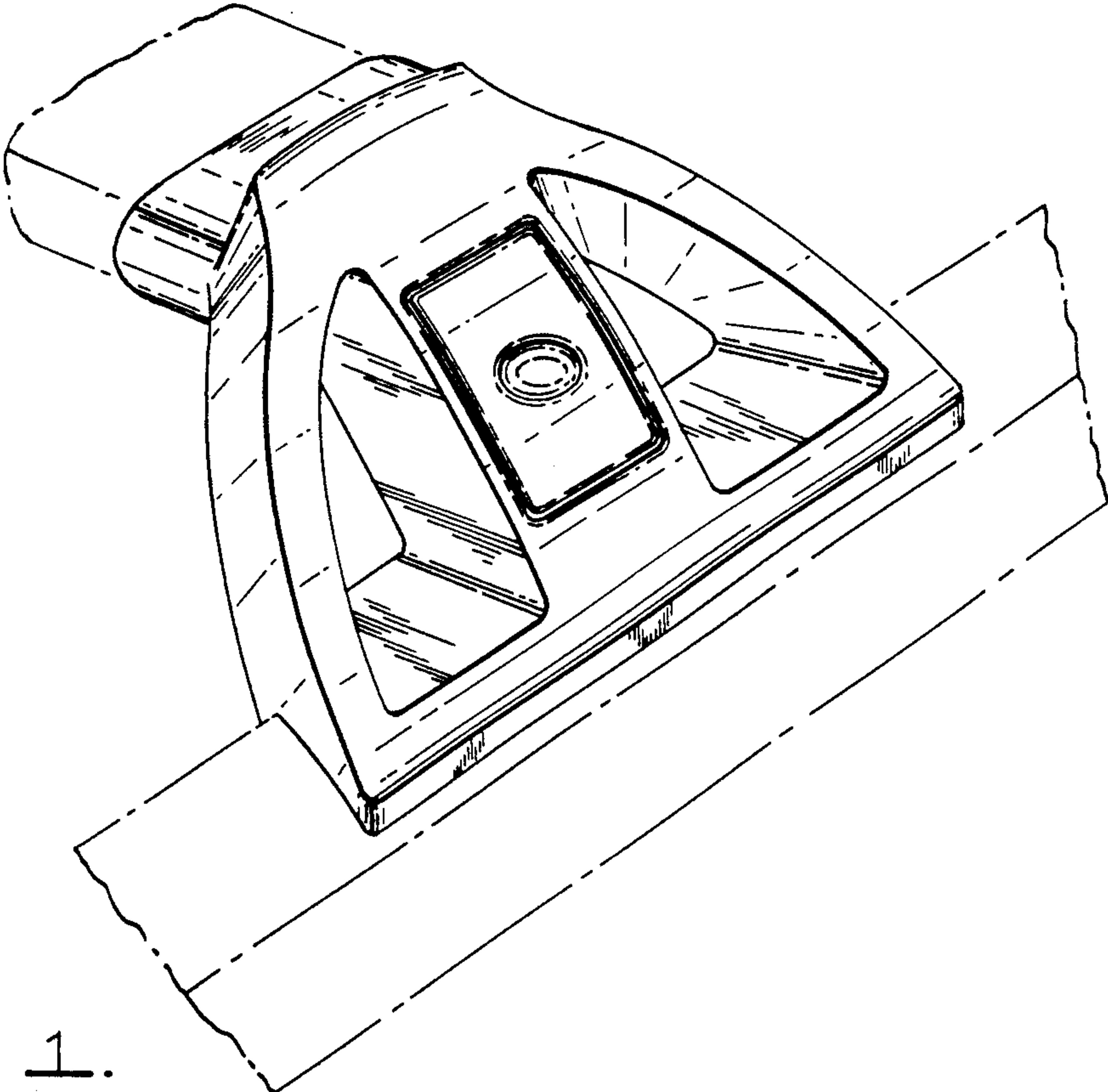

FIG. 1.

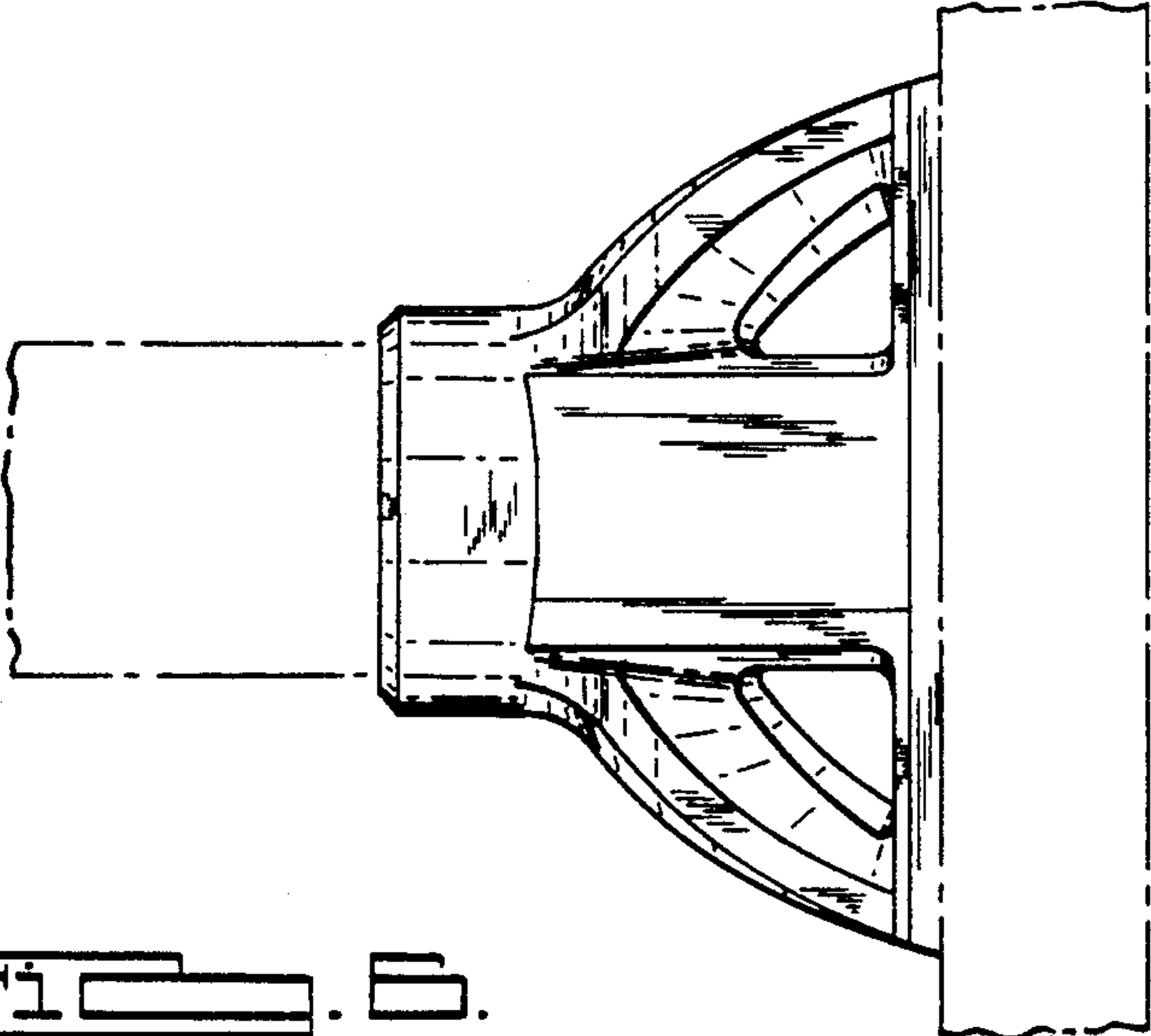

FIG. 2.

