

[54] CEILING LIGHTING FIXTURE

[76] Inventors: Brigitte Bischof, Kohlstrasse 23, 4920 Lemgo 1; Horst-Dieter Schmelzer, Forthofstrasse 23, 4815 Schloss Holte-Stukenbrock, both of Fed. Rep. of Germany

[\*\*] Term: 14 Years

[21] Appl. No.: 260,760

[22] Filed: Oct. 21, 1988

[52] U.S. Cl. .... D26/91; D26/76

[58] Field of Search ..... D26/118, 128-137, D26/72, 75, 77, 78, 80-92, 76; 362/147, 362, 404-408, 21, 217, 219, 220, 222, 223, 228

[56] References Cited

U.S. PATENT DOCUMENTS

D. 236,646	9/1975	Stewart	.....	D26/85
D. 293,723	1/1988	Büttner	.....	D26/91
D. 294,067	2/1988	Ambasz	.....	D26/88 X
D. 299,762	2/1989	King et al.	.....	D26/87
2,022,078	11/1935	Dorey	.....	362/339
3,457,396	7/1969	Mrsny	.....	D26/85 X
4,425,603	1/1984	Courson	.....	362/408 X

OTHER PUBLICATIONS

Abitare, 9-1979, p. 123, Fluorescent Lamp (9).  
Progress Commercial Lighting Catalog 200, ©1965, p. 18, Hanging Lamp #P4414.  
Thorlux Lighting Brochure, 1986, p. 2, "Asmet" Flood-light.

Primary Examiner—Susan J. Lucas  
Attorney, Agent, or Firm—Millen, White & Zelano

[57] CLAIM

The ornamental design for a ceiling lighting fixture, as shown and described.

DESCRIPTION

FIG. 1 is a top, end perspective view of a ceiling lighting fixture showing our new design, the fixture being fragmentarily shown to indicate indeterminate length; FIG. 2 is a top plan view thereof, the bottom being a mirror image;

FIG. 3 is a side elevational view thereof, the opposite side being identical; FIG. 4 is a bottom, opposite end perspective view thereof; FIG. 5 is an end elevational view thereof; FIG. 6 is a top, end perspective view of a second embodiment of our new design; FIG. 7 is a top plan view thereof, the bottom being a mirror image; FIG. 8 is a side elevational view thereof, the opposite side being identical; FIG. 9 is a bottom, opposite end perspective view thereof; FIG. 10 is a top, end perspective view of a third embodiment of our new design, the fixture being fragmentarily shown to indicate indeterminate length; FIG. 11 is a top plan view thereof, the bottom being a mirror image; FIG. 12 is a side elevational view thereof, the opposite side being identical; FIG. 13 is a bottom, opposite end perspective view thereof; FIG. 14 is an end elevational view thereof; FIG. 15 is top, end perspective view of a fourth embodiment of our new design; FIG. 16 is a top plan view thereof, the bottom being a mirror image; FIG. 17 is a side elevational view thereof, the opposite side being identical; FIG. 18 is a bottom, opposite end perspective view thereof; FIG. 19 is a top, end perspective view of a fifth embodiment of our design, the fifth embodiment consisting of a pair of the fixtures of the fourth embodiment; FIG. 20 is a top, end perspective view of a sixth embodiment of our new design, the fixture being fragmentarily shown to indicate indeterminate length, the bottom, opposite end view being a mirror image; FIG. 21 is an end elevational view thereof; FIG. 22 is a top, end perspective view of a seventh embodiment of our new design, the bottom, opposite end view being a mirror image; FIG. 23 is a top, end perspective view of an eighth embodiment of our new design; FIG. 24 is a top plan view thereof;

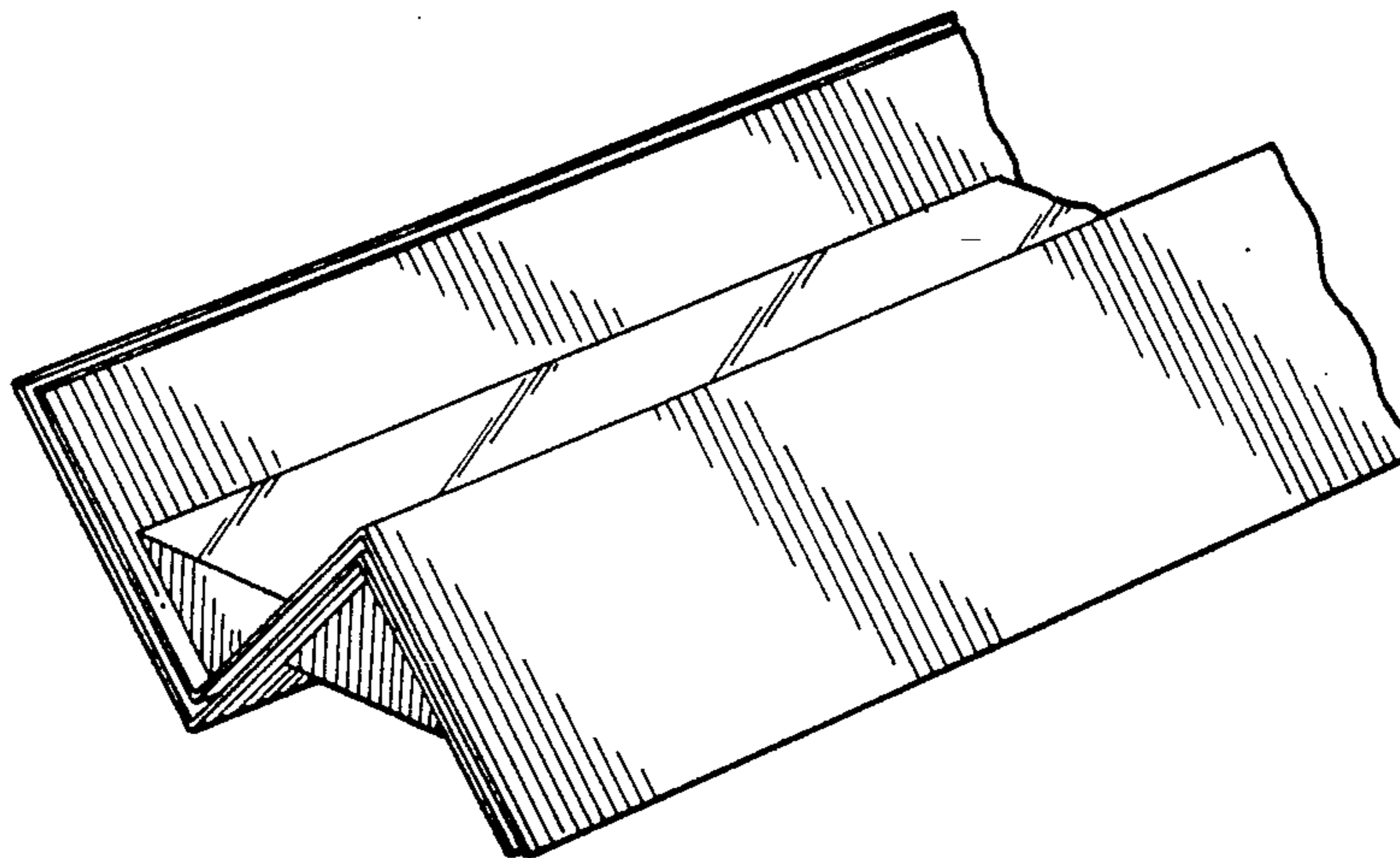


FIG. 25 is a side elevational view thereof, the opposite side being identical;

FIG. 26 is a bottom, opposite end perspective view thereof;

FIG. 27 is a top, end perspective view of a ninth embodiment of our new design, the ninth embodiment being identical to the eighth embodiment, but in an inverted position;

FIG. 28 is a top, end perspective view of a tenth embodiment of our new design, the fixture being fragmentarily shown to indicate indeterminate length;

FIG. 29 is a bottom, opposite end perspective view thereof;

FIG. 30 is a top plan view thereof, the bottom being a mirror image;

FIG. 31 is an end elevational view thereof;

FIGS. 32 and 33 are respectively top and bottom perspective views taken from opposite ends of an eleventh embodiment of our new design, the eleventh embodi-

ment being identical to the tenth embodiment, but in an inverted position;

FIGS. 34 and 35 are respectively top and bottom perspective views taken from the opposite ends and sides of a twelfth embodiment of our new design;

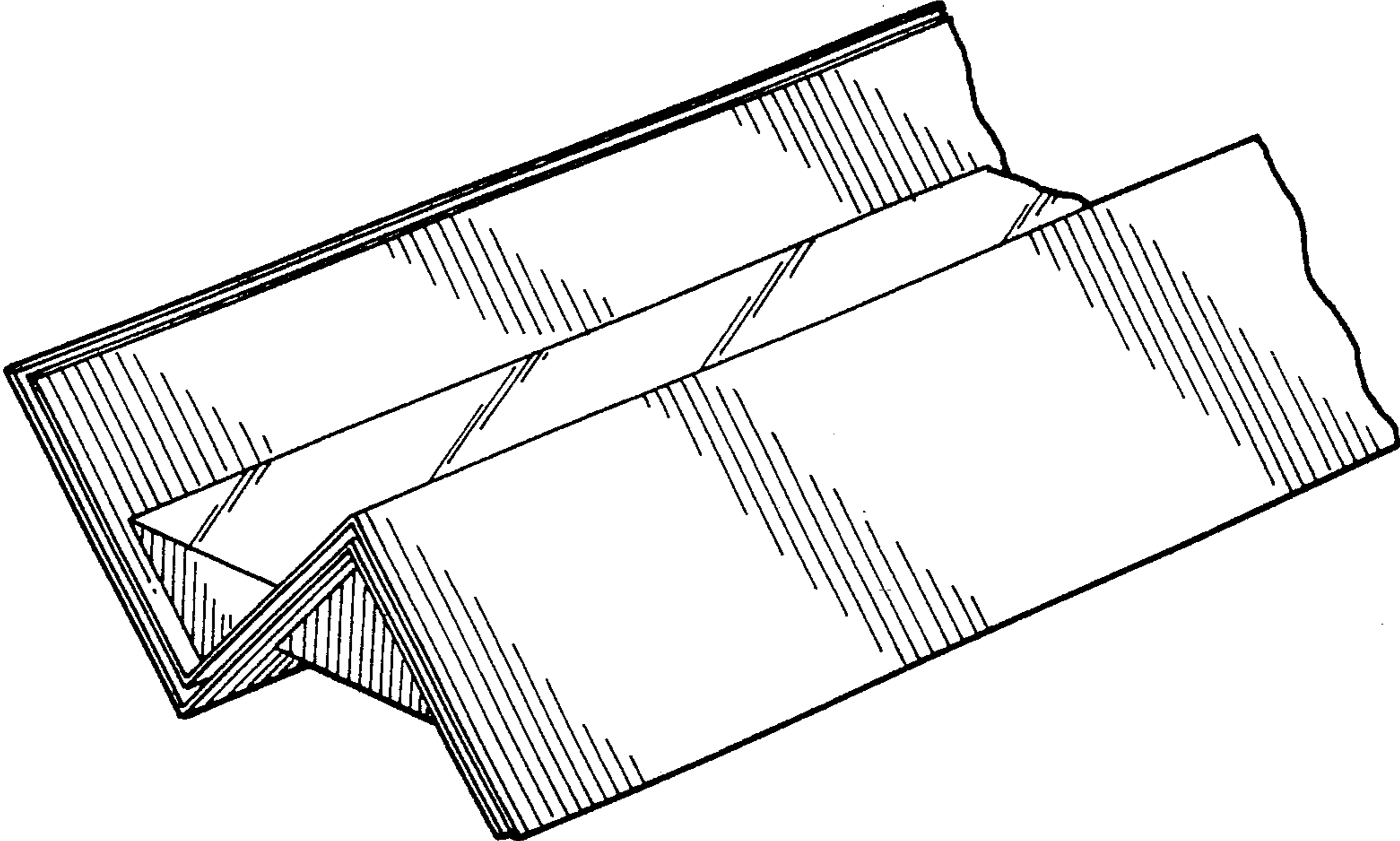
FIGS. 36 and 37 are respectively top and bottom perspective views taken from the opposite ends and sides of a thirteenth embodiment of our new design;

FIG. 38 is a top, end perspective view of a fourteenth embodiment of our new design;

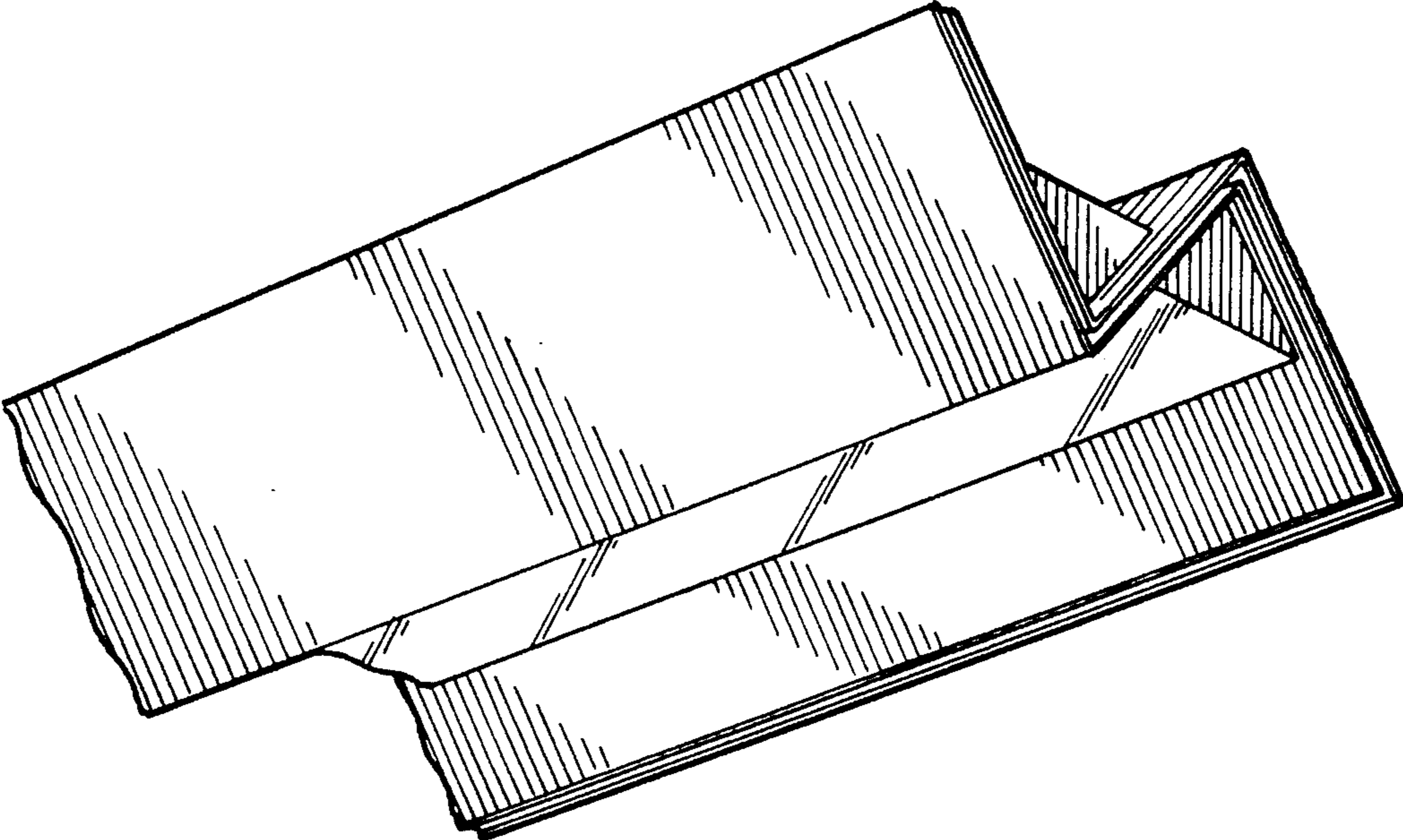
FIG. 39 is an inverted bottom, opposite end perspective view thereof;

FIGS. 40 and 41 are respectively top and bottom perspective views taken from the opposite ends and sides of a fifteenth embodiment of our new design; and

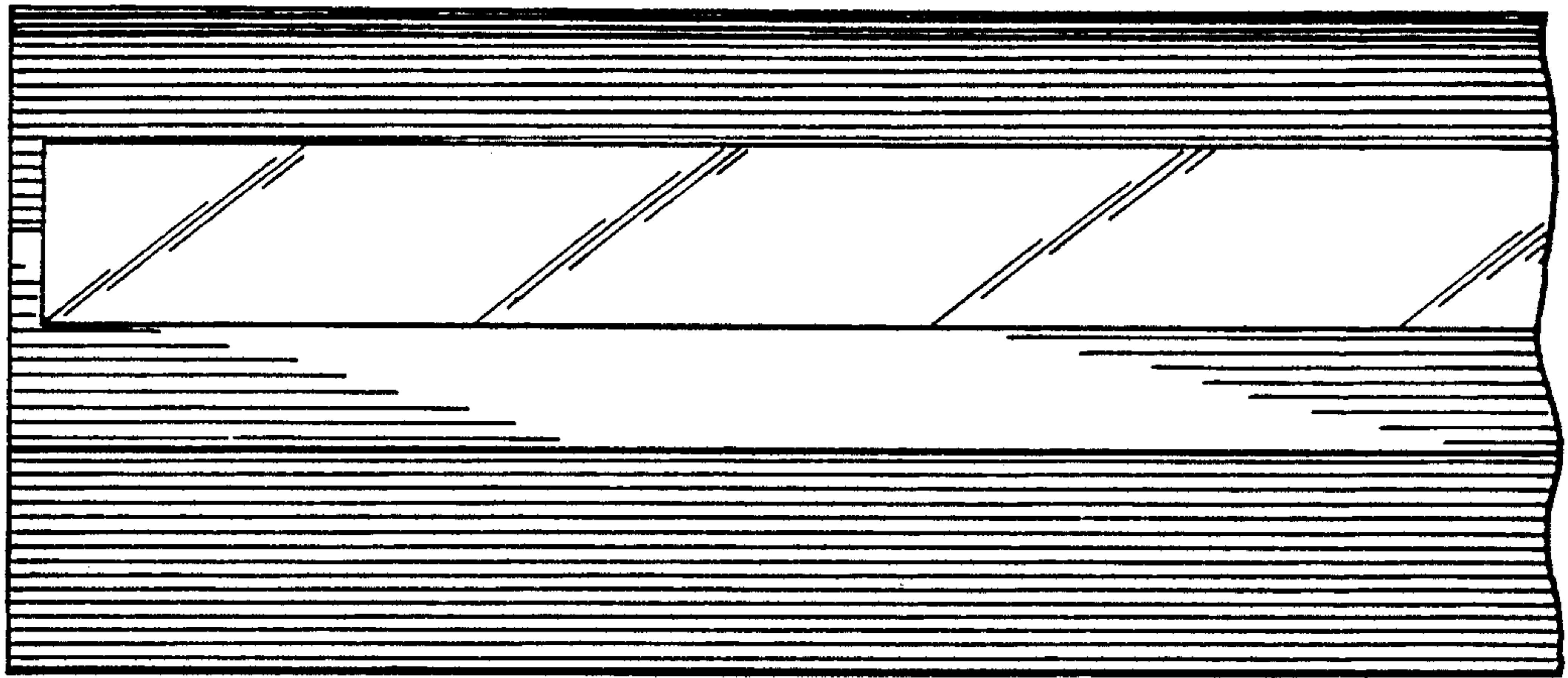
FIGS. 42 and 43 are respectively top and bottom perspective views taken from the opposite ends and sides of a sixteenth embodiment of our new design.



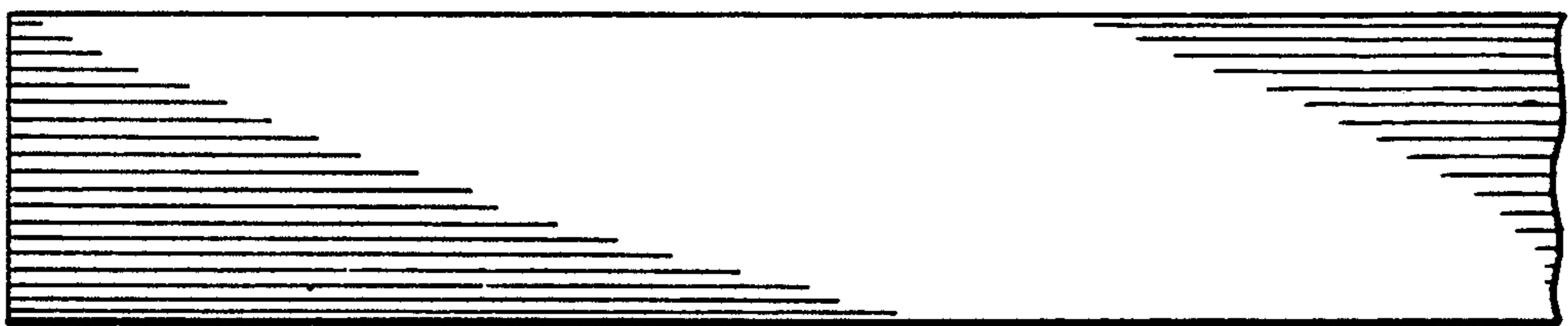
**FIG. 1**



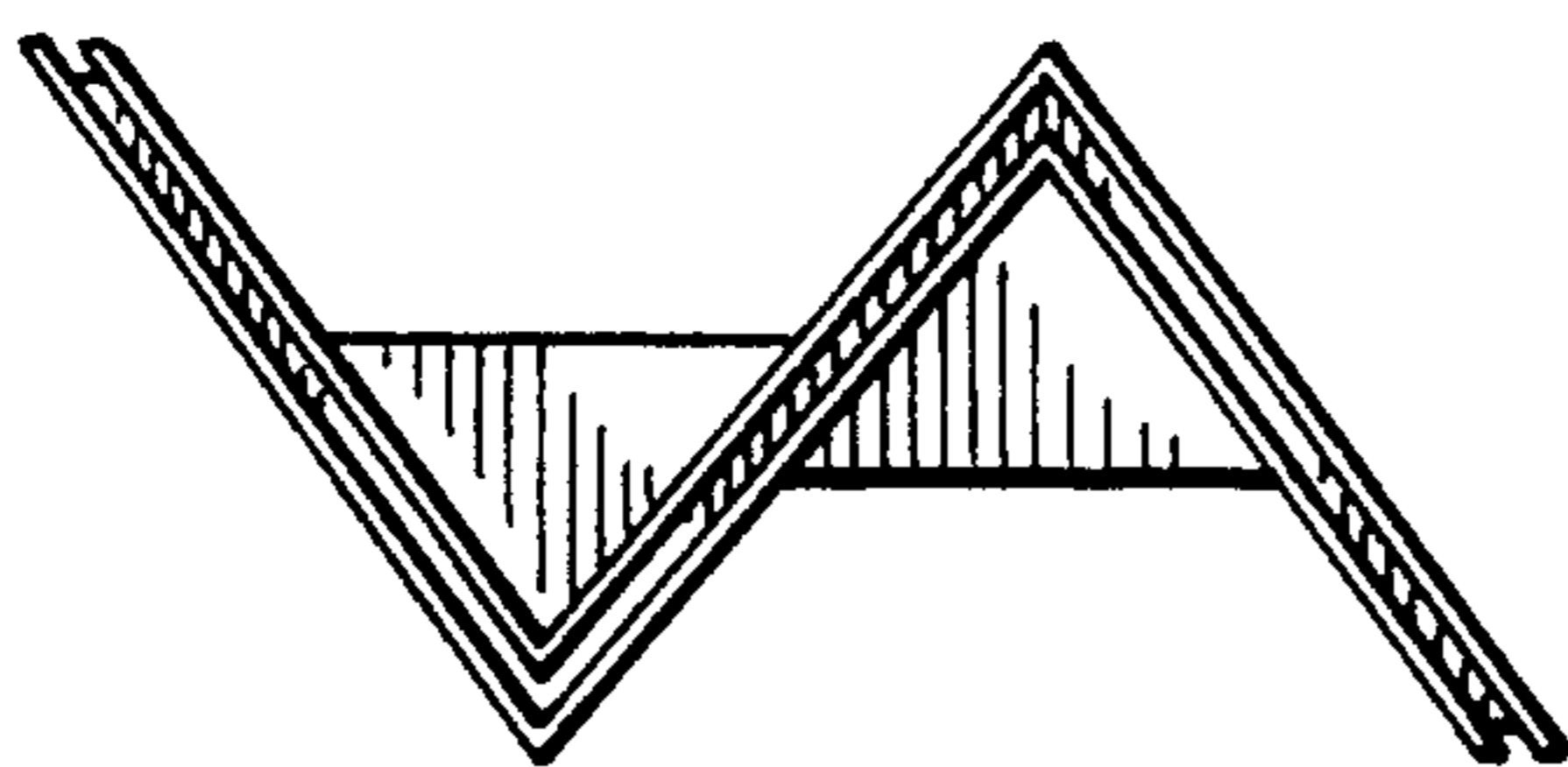
**FIG. 4**



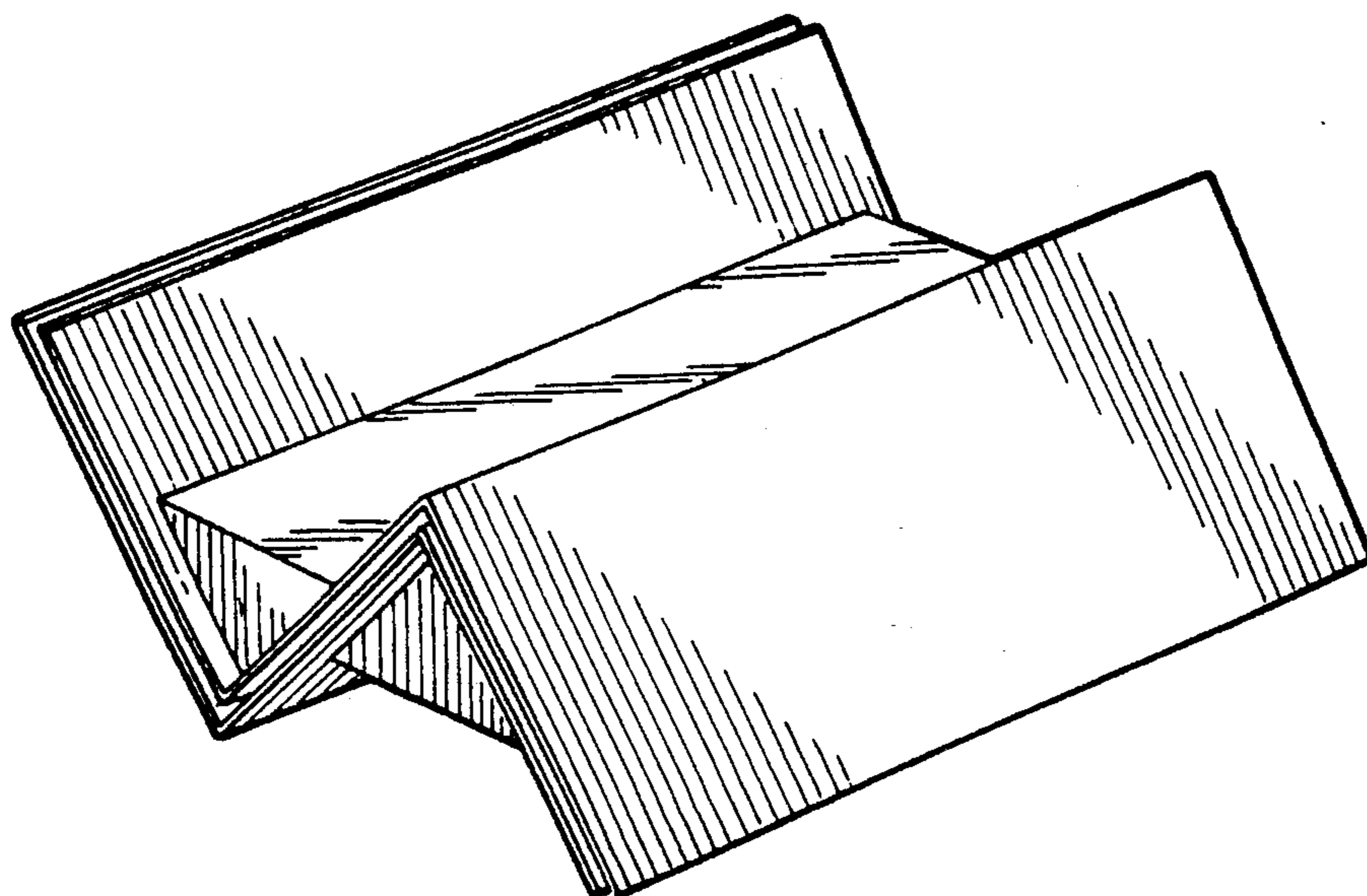
**FIG. 2**



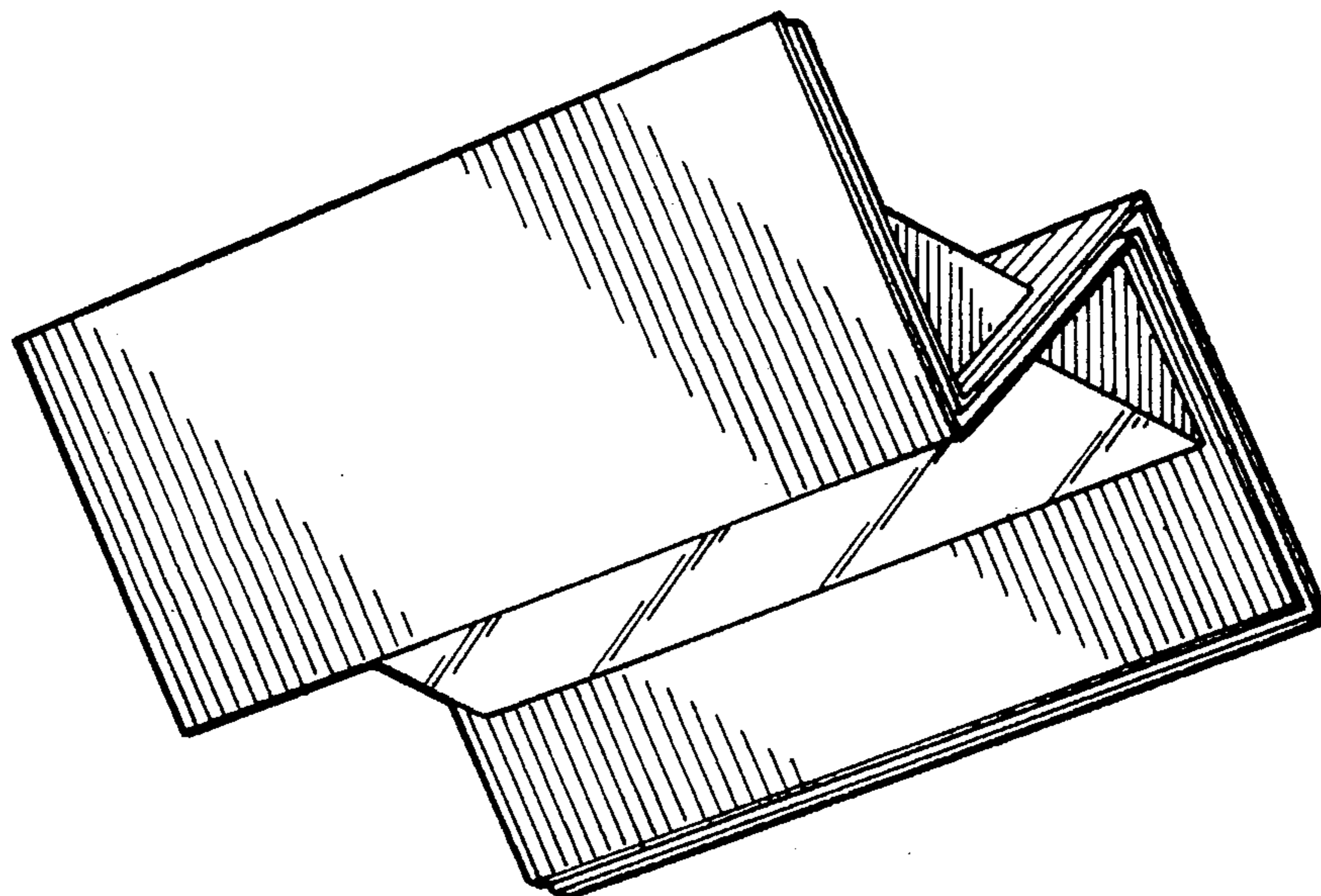
**FIG. 3**



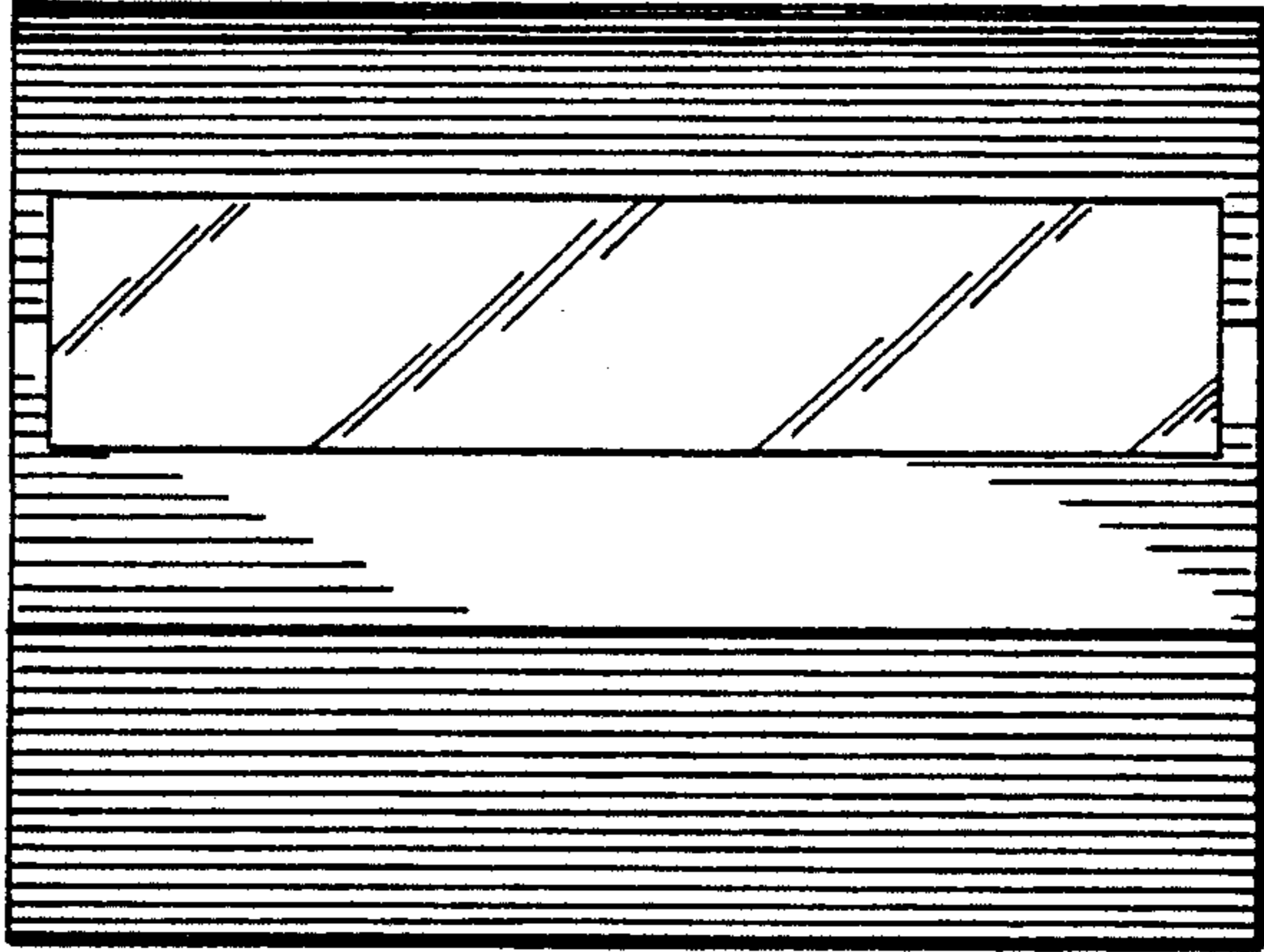
**FIG. 5**



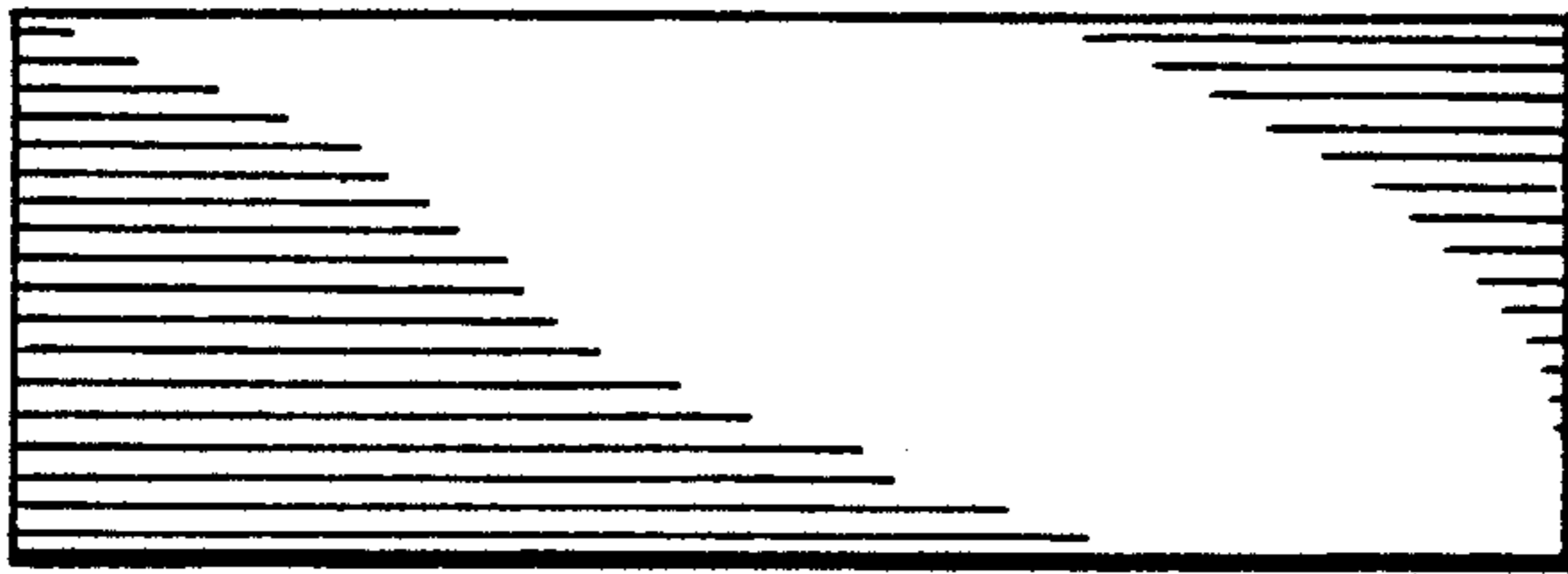
**FIG. 6**



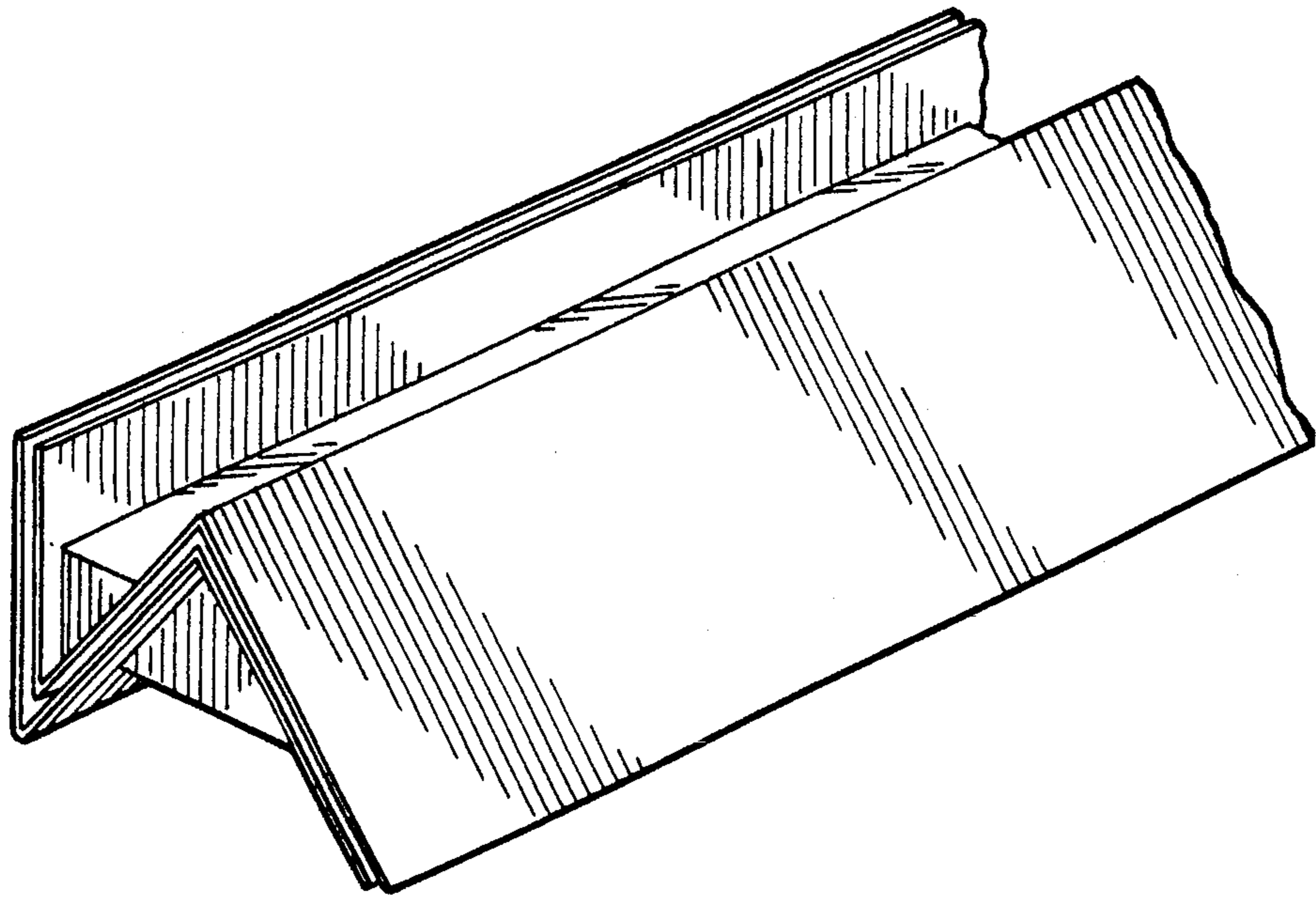
**FIG. 9**



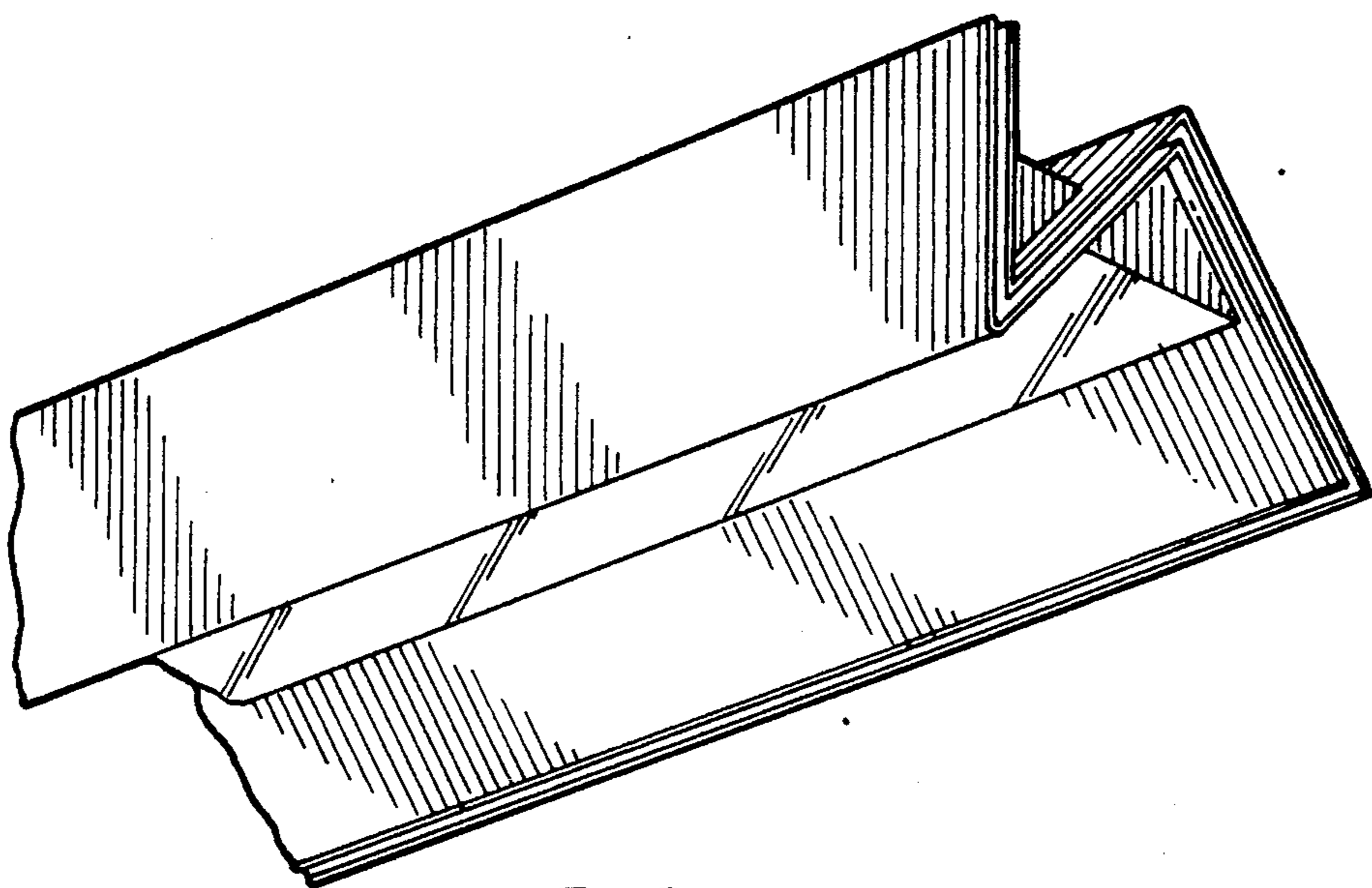
**FIG. 7**



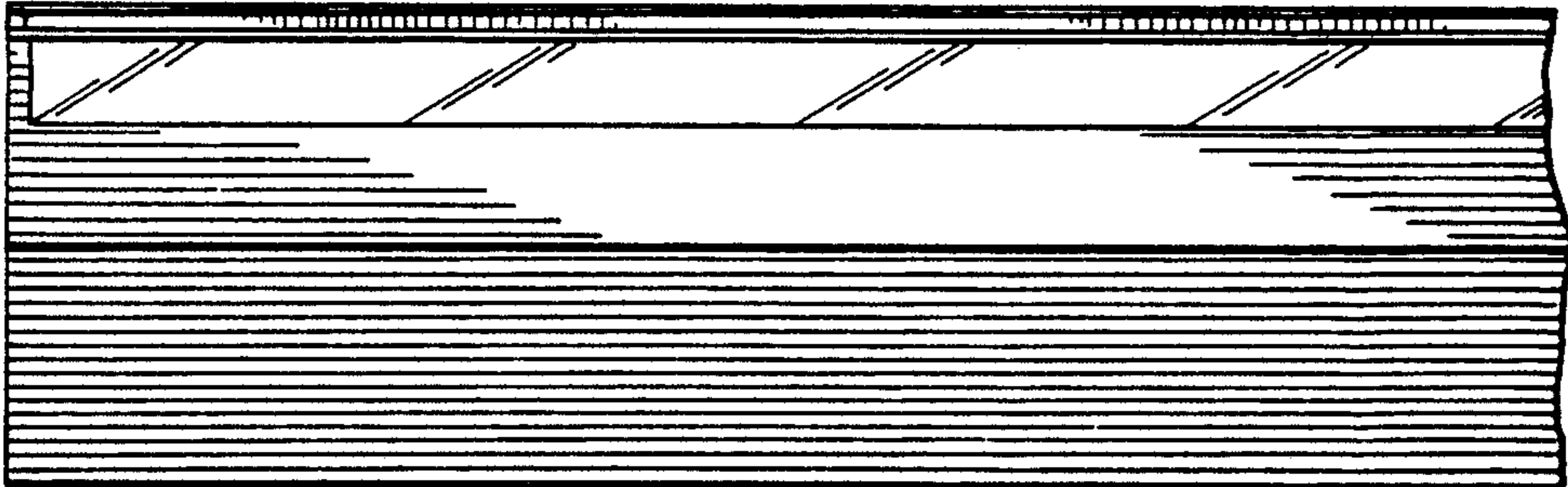
**FIG. 8**



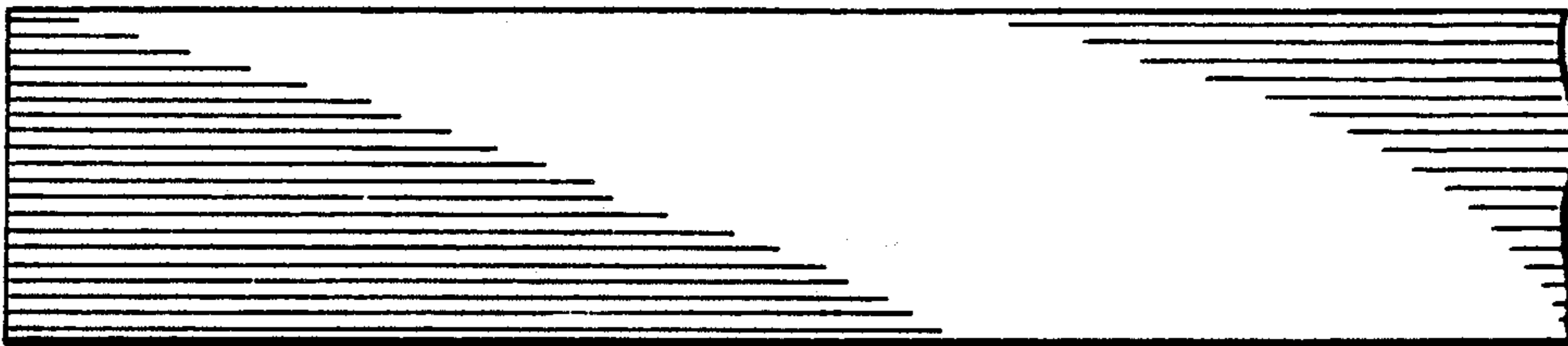
**FIG. 10**



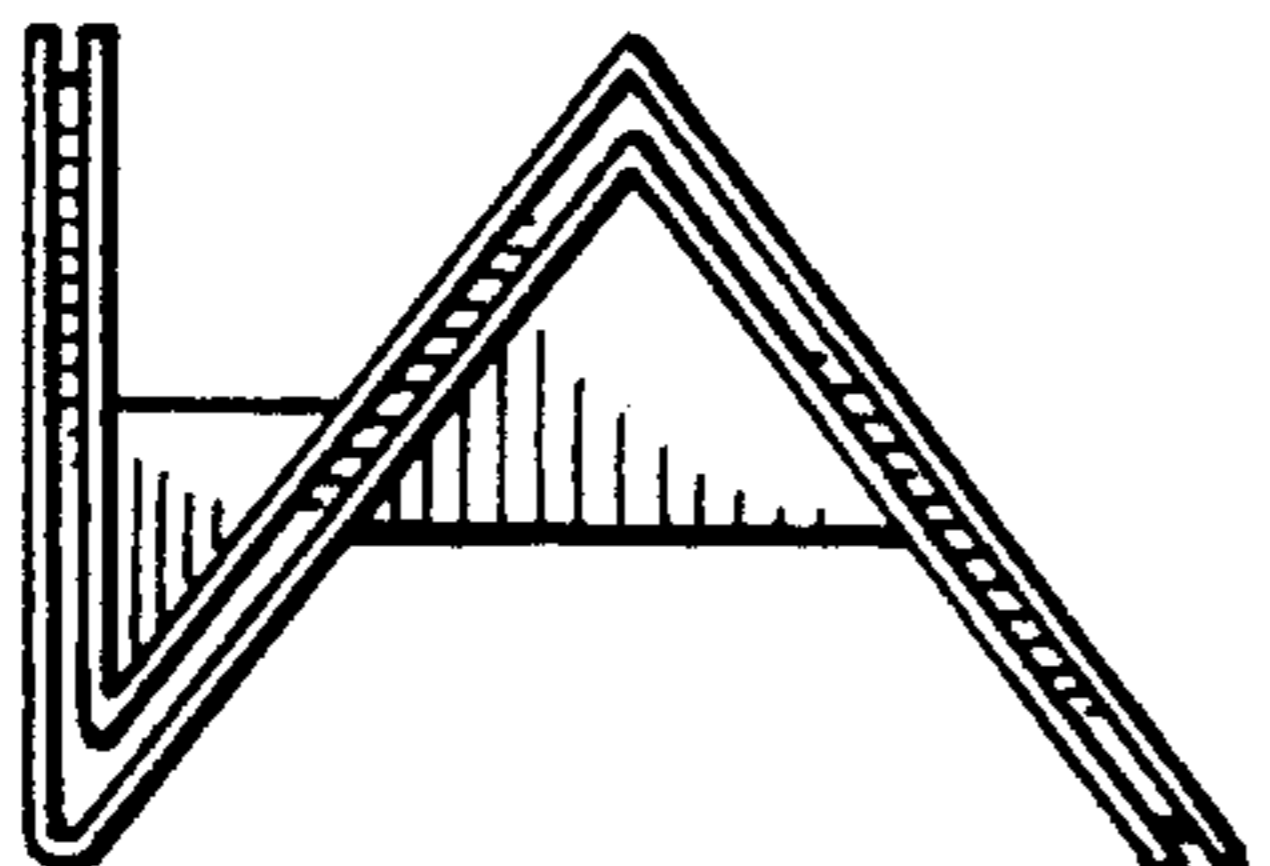
**FIG. 13**



**FIG. 11**

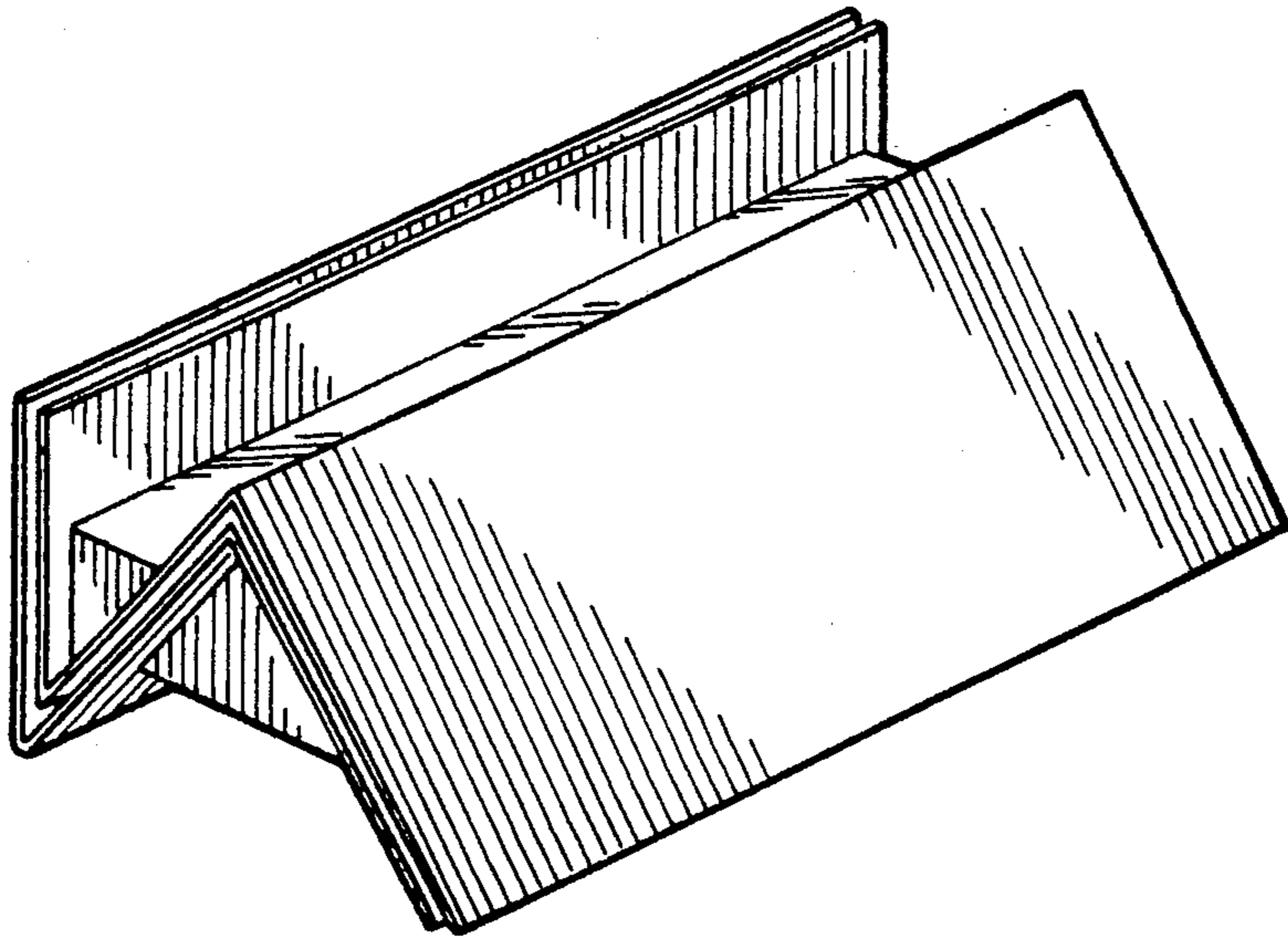


**FIG. 12**

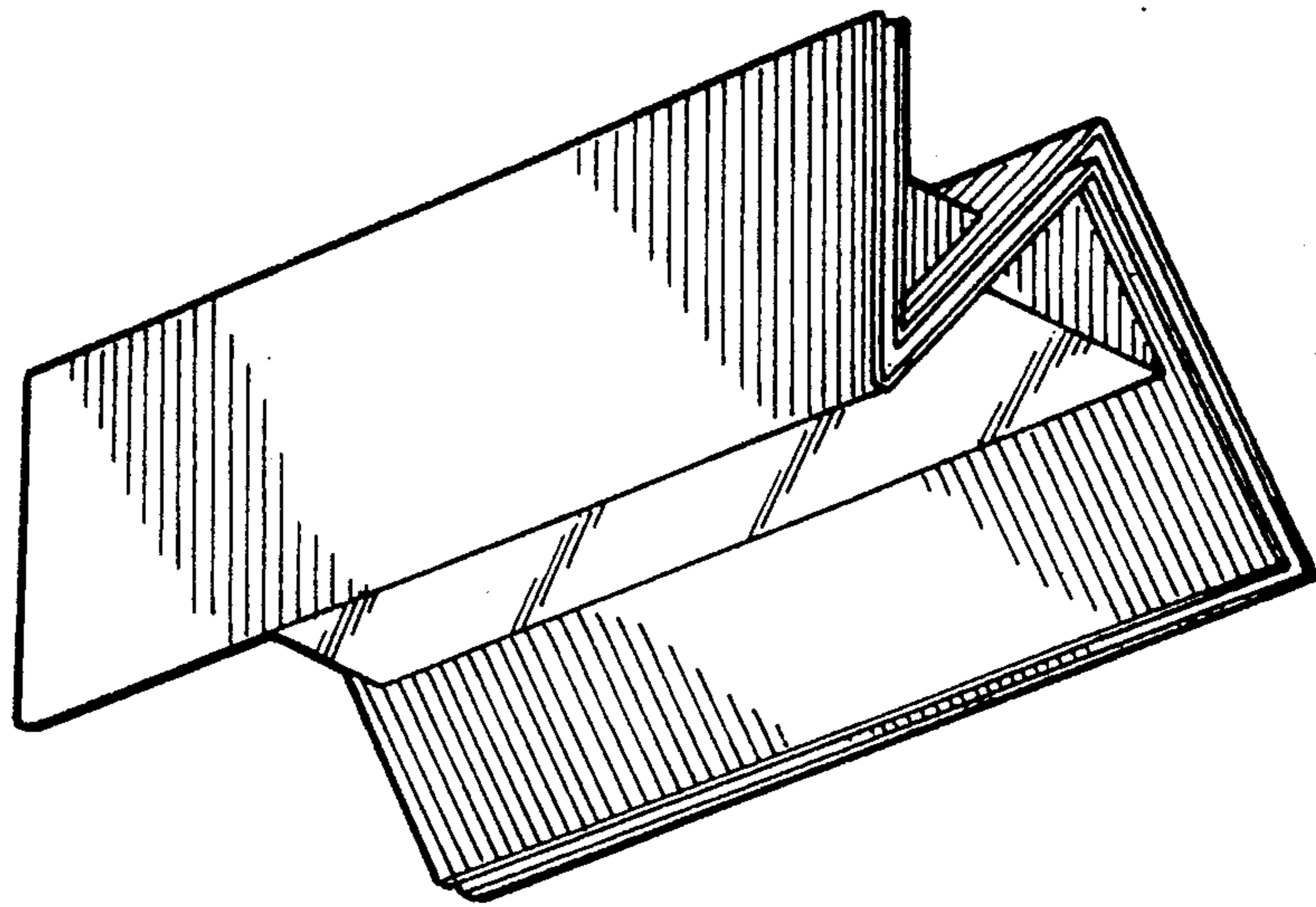


**FIG. 14**

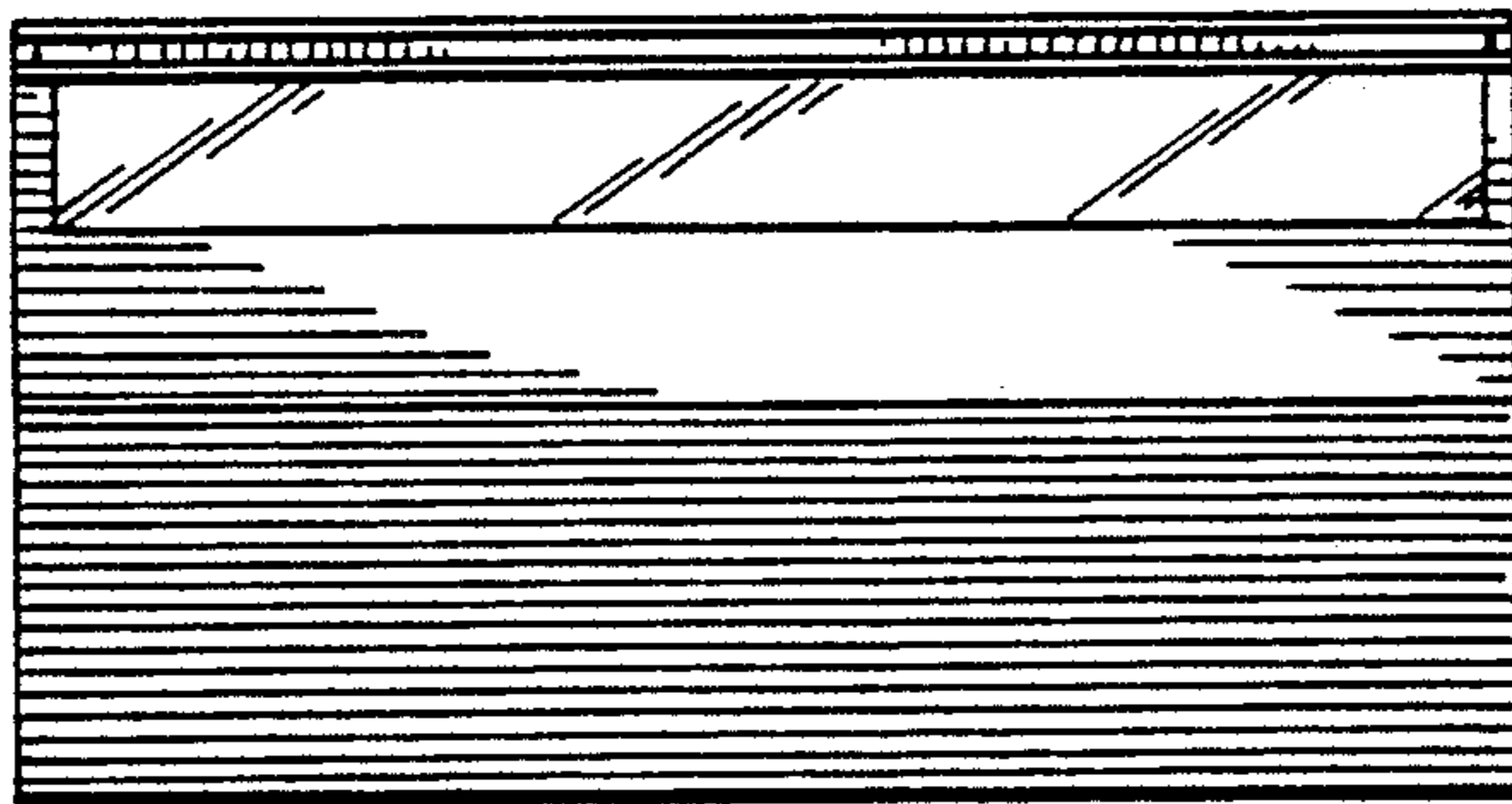




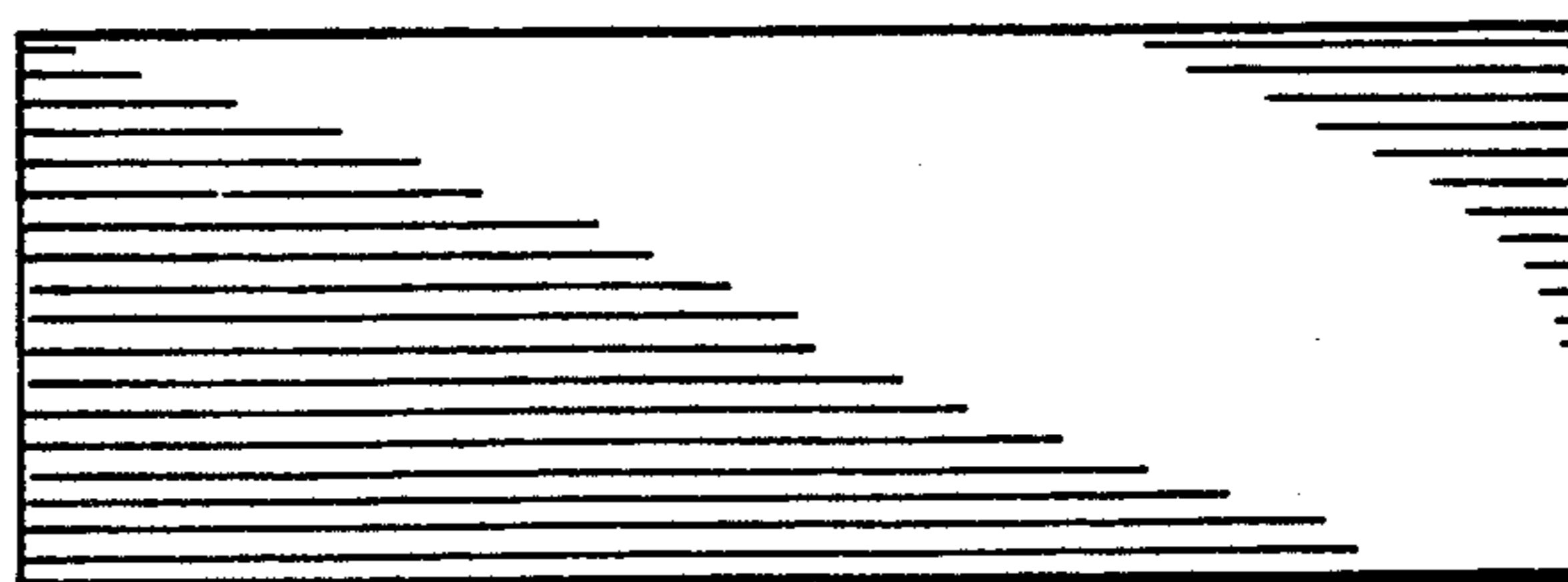
**FIG. 15**



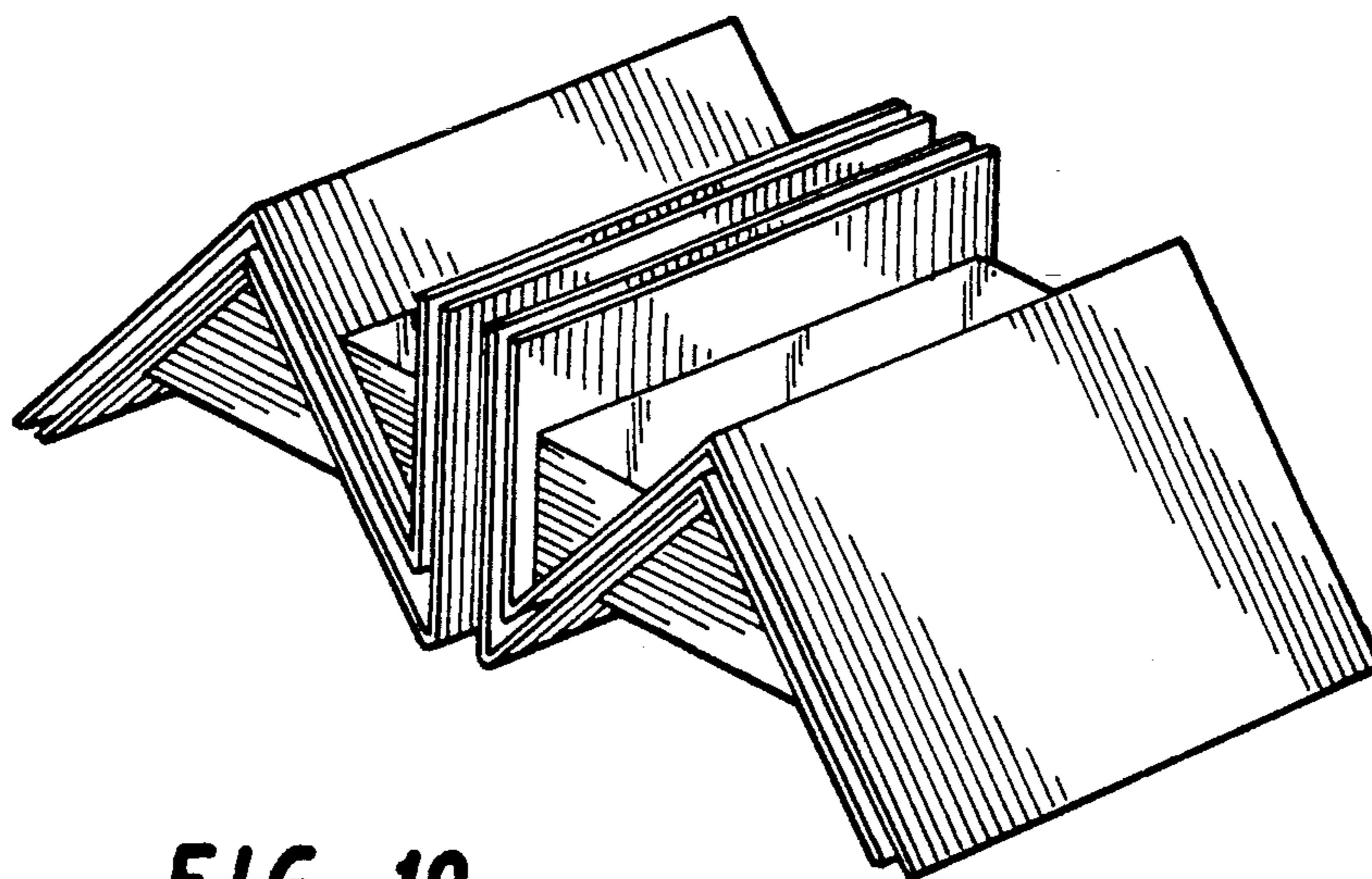
**FIG. 18**



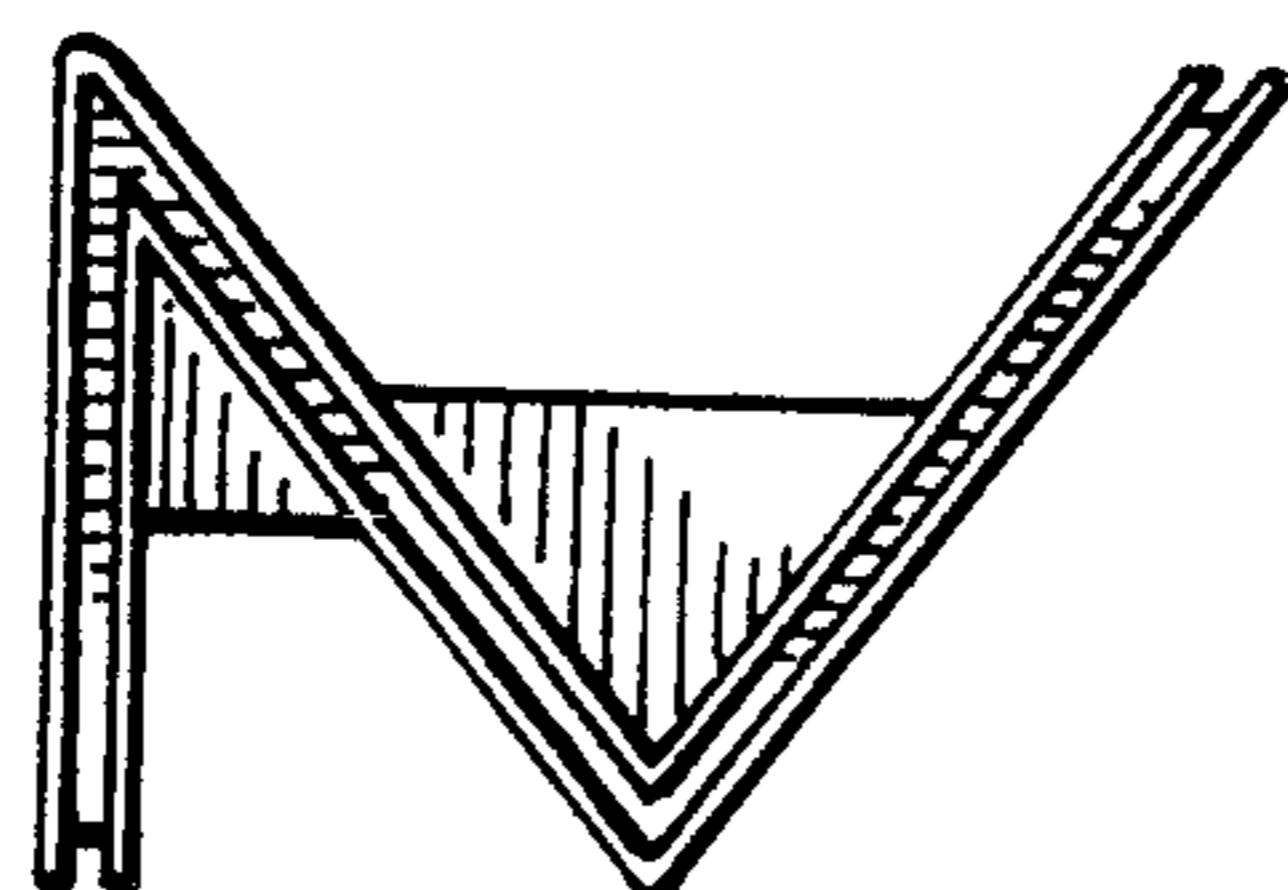
**FIG. 16**



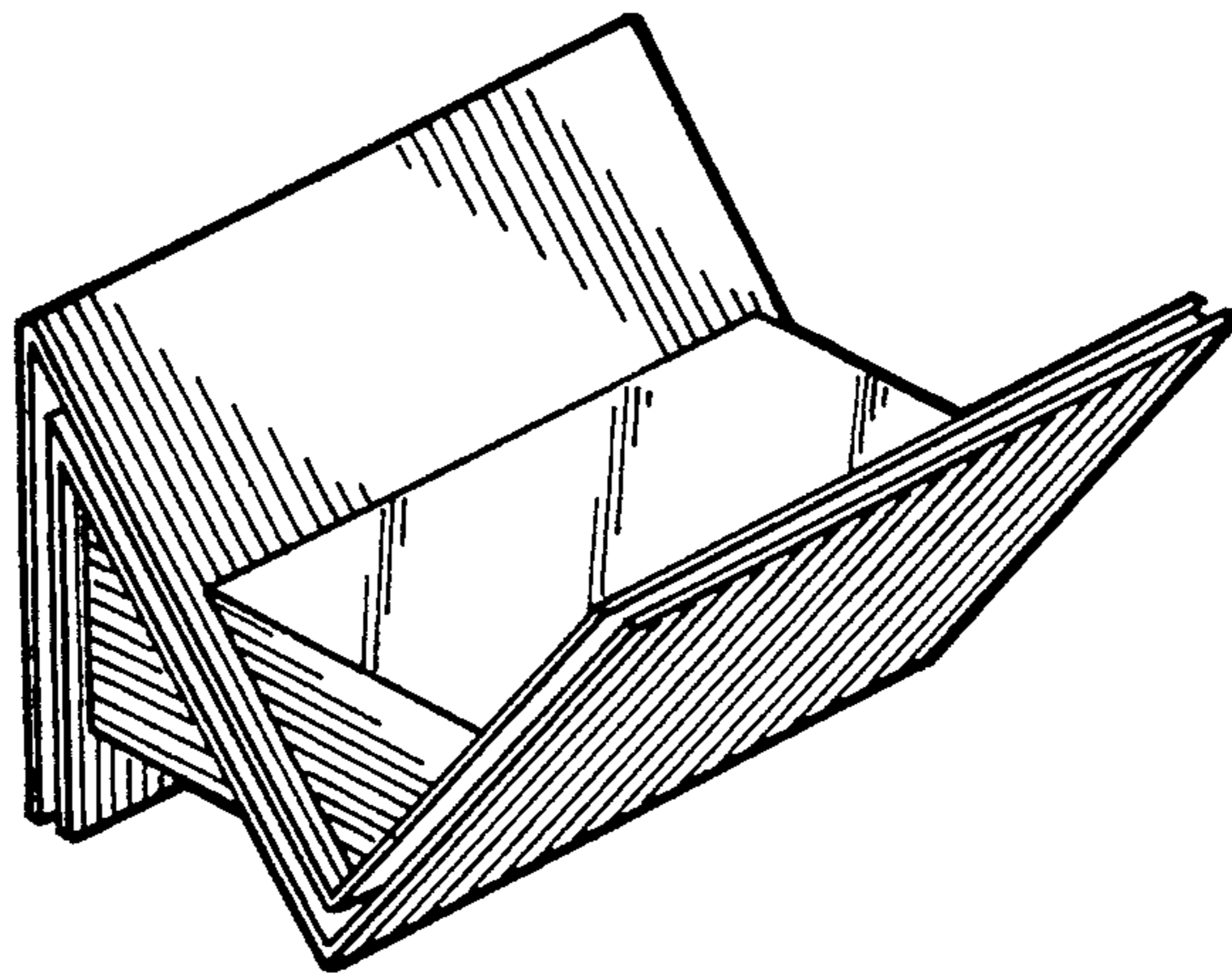
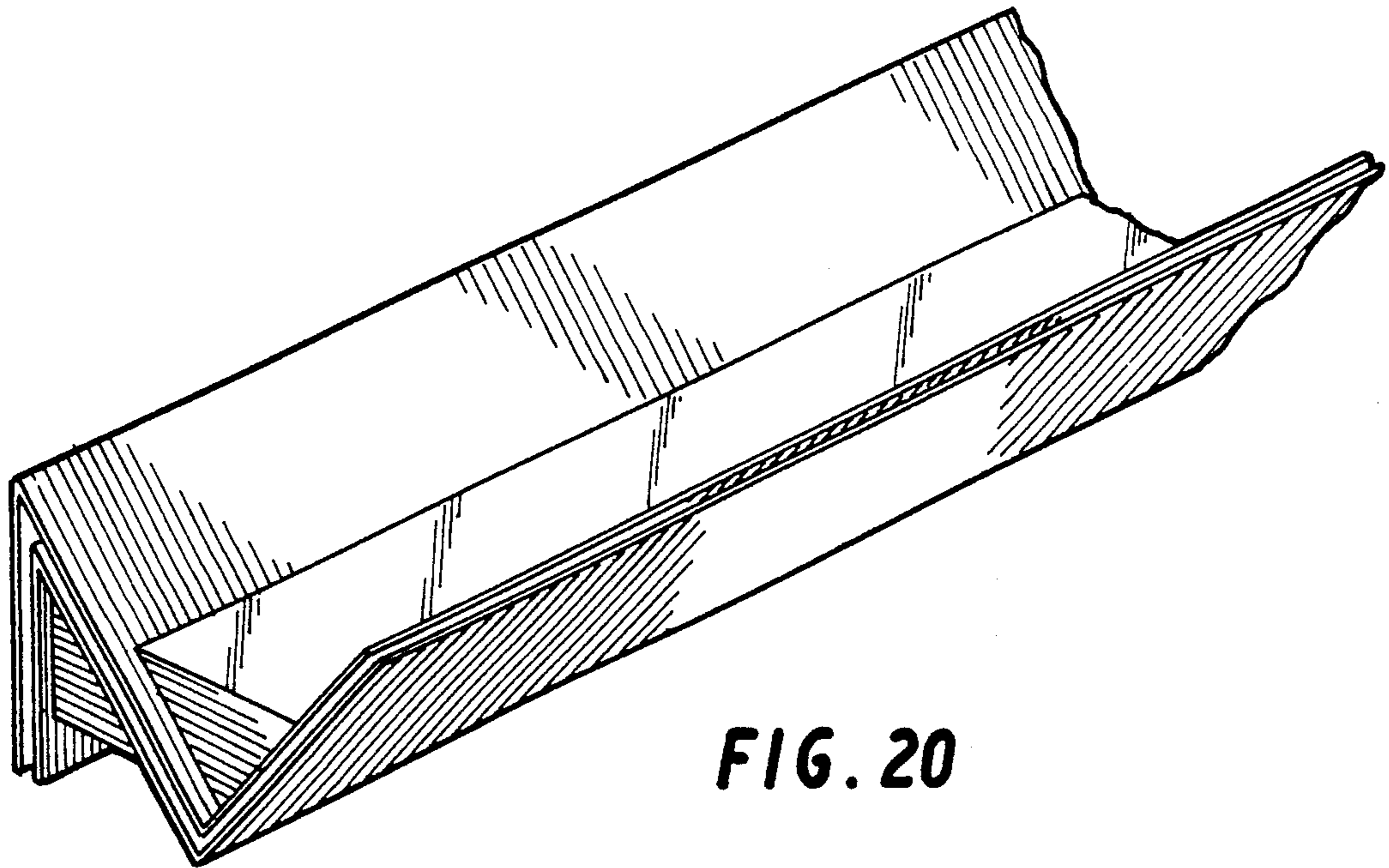
**FIG. 17**

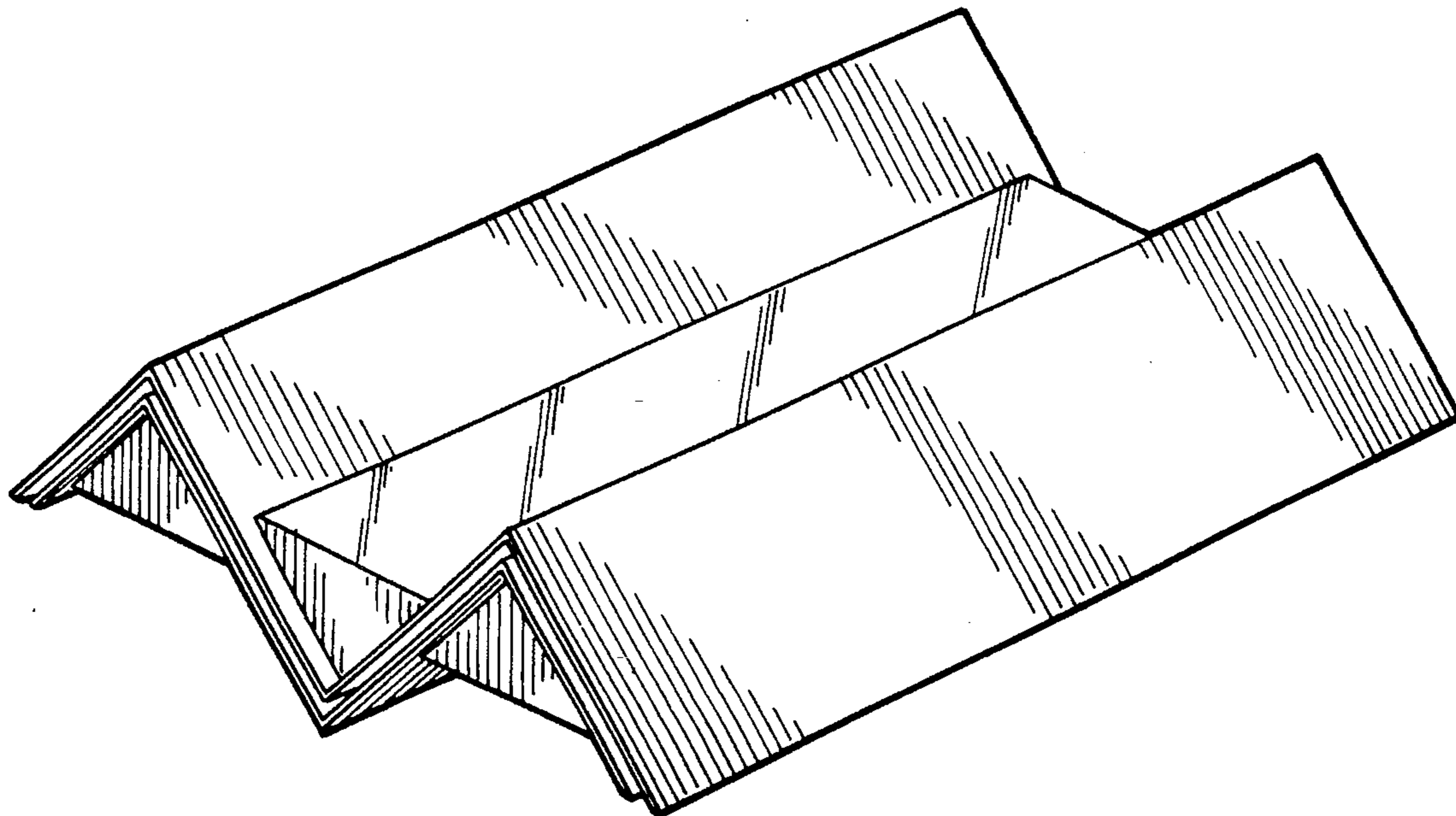


**FIG. 19**

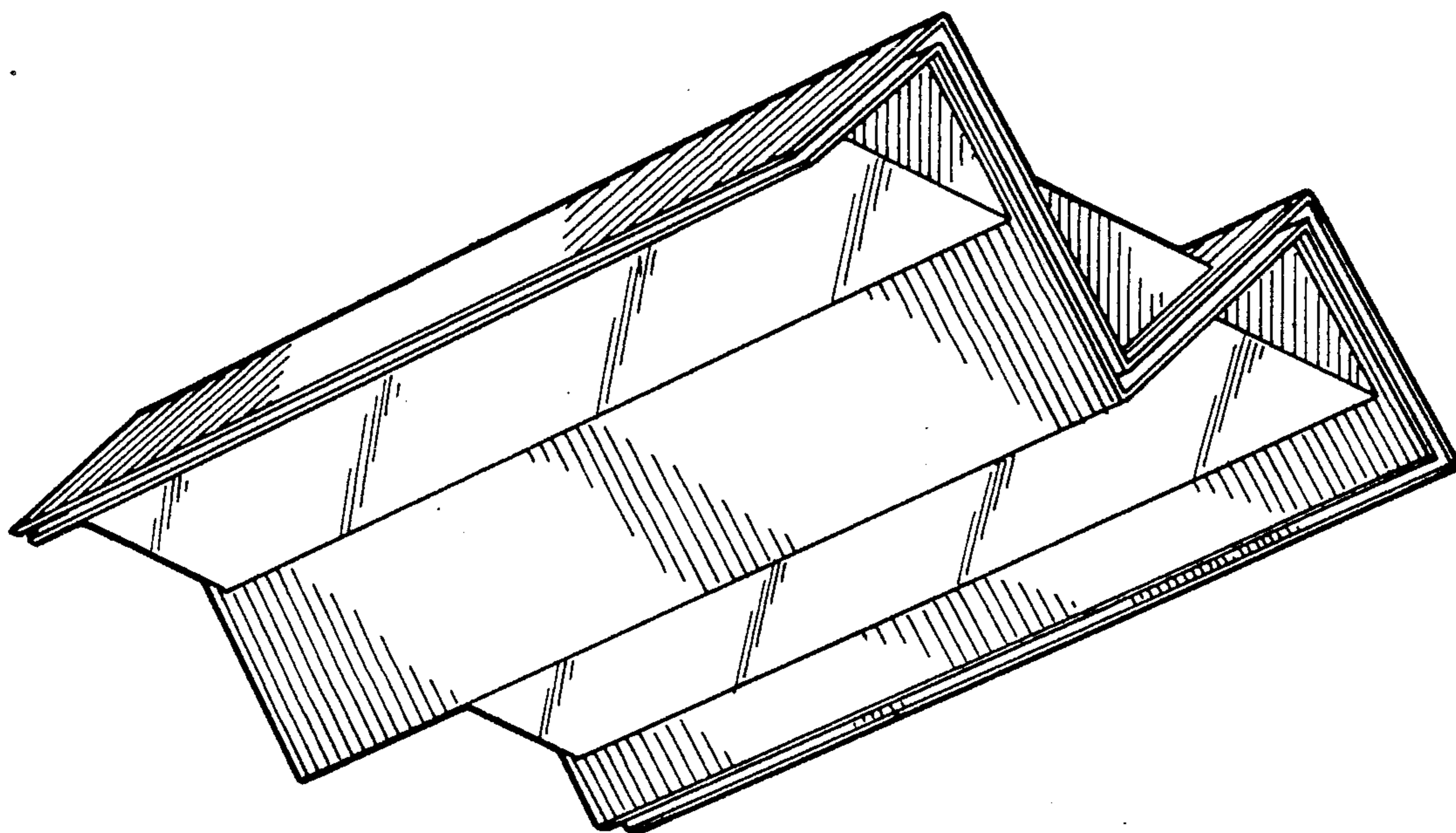


**FIG. 21**

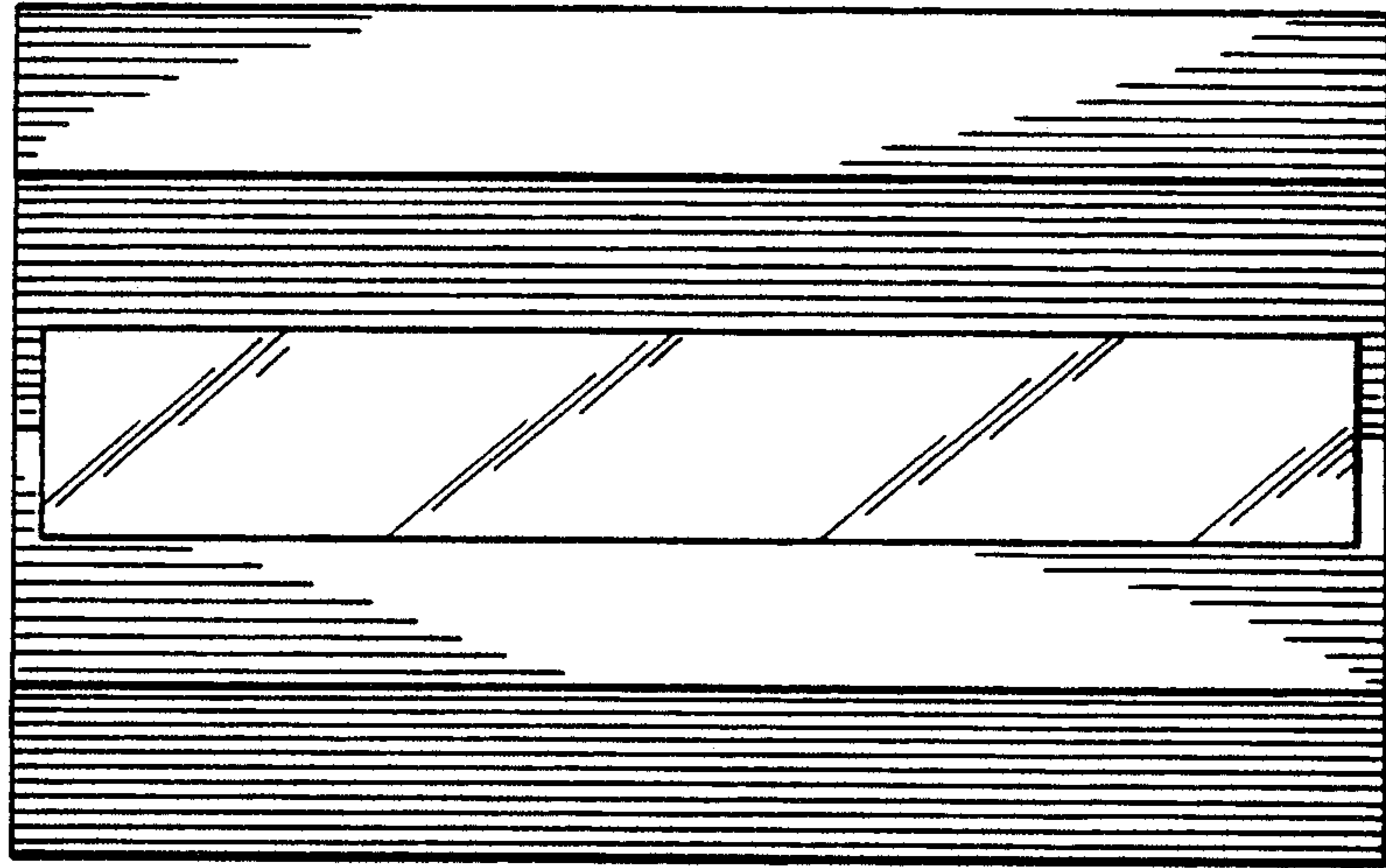




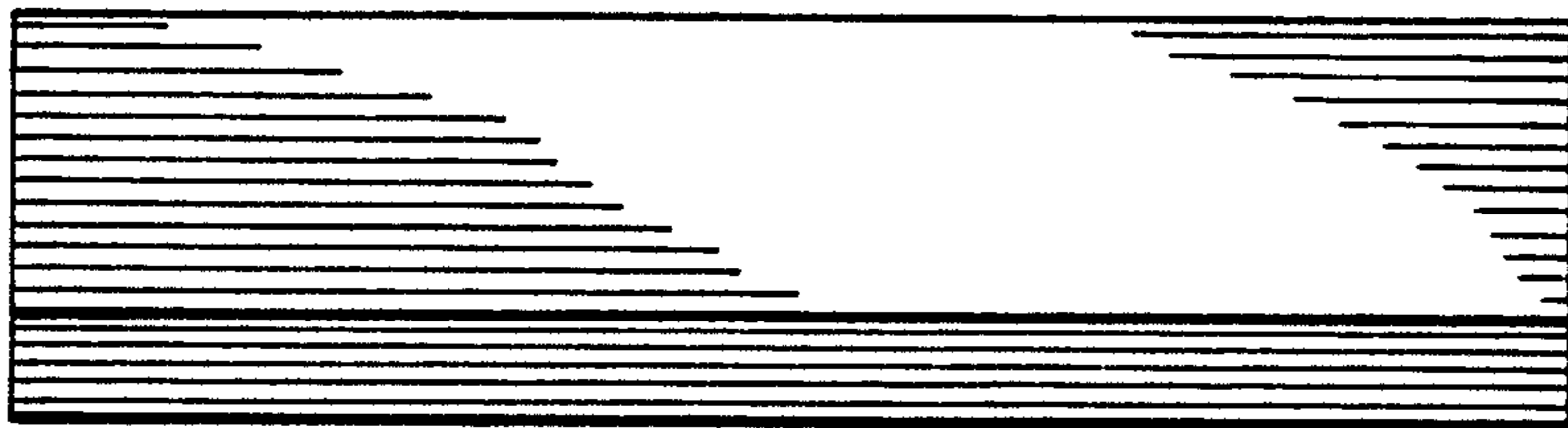
**FIG. 23**



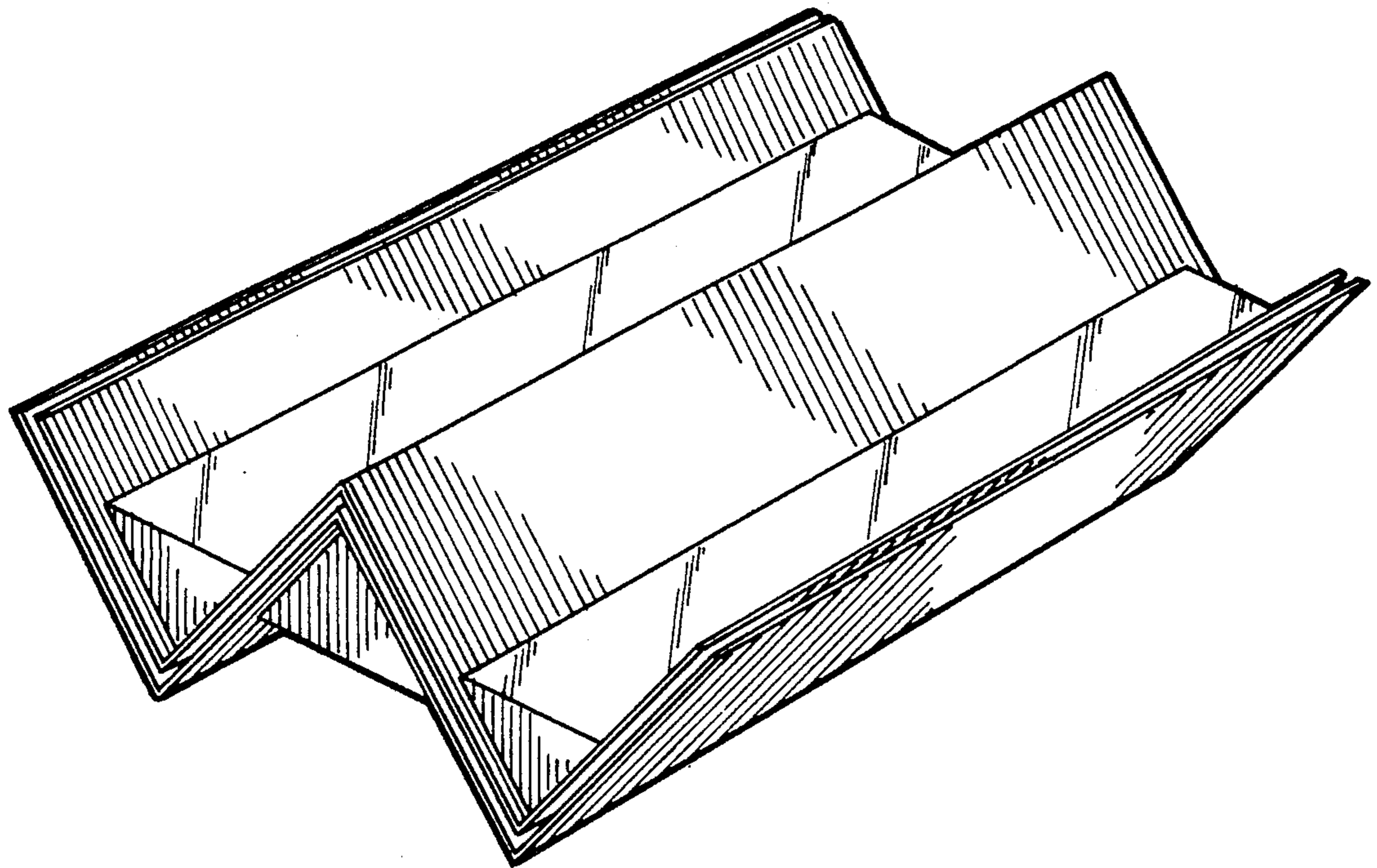
**FIG. 26**



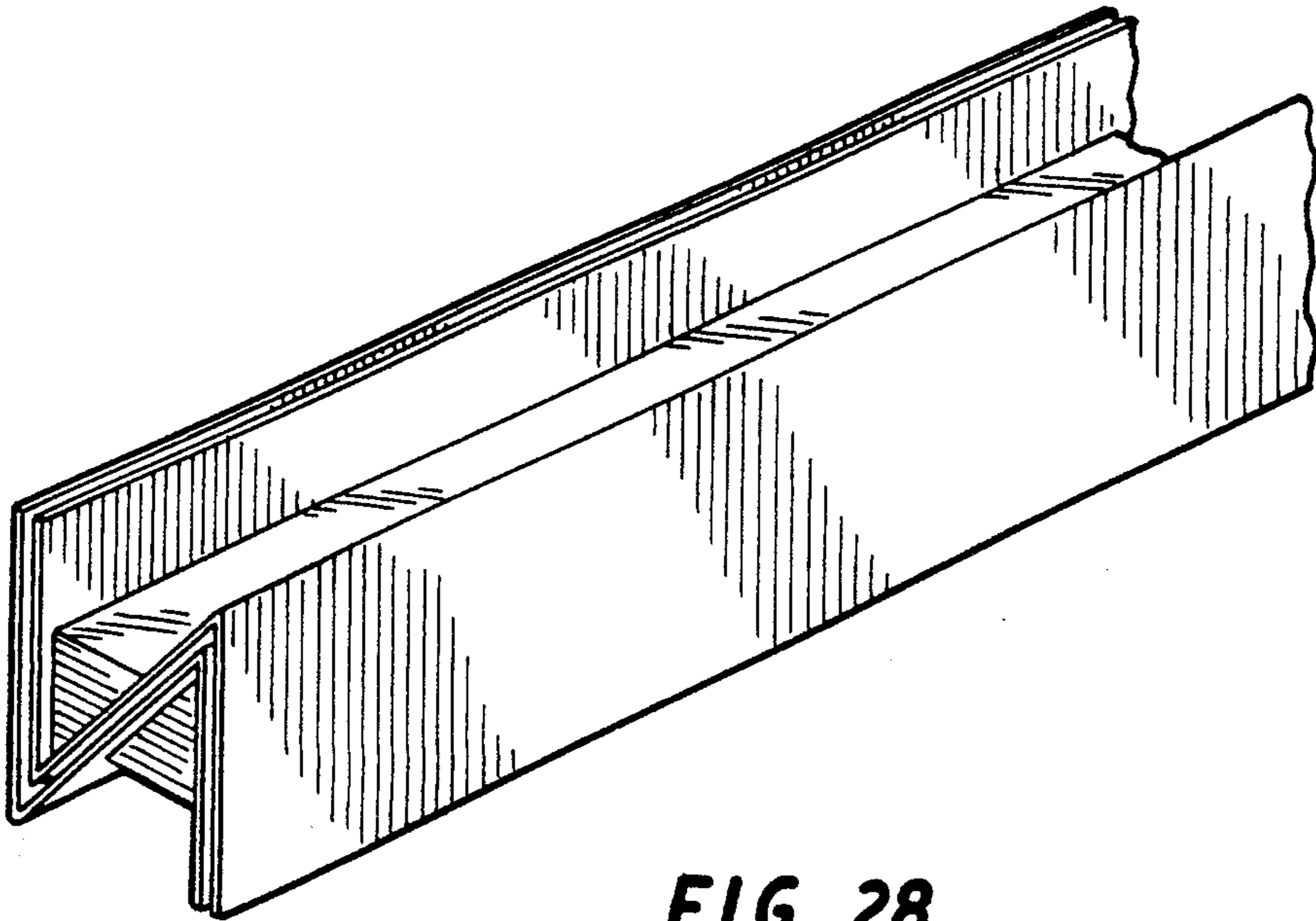
**FIG. 24**



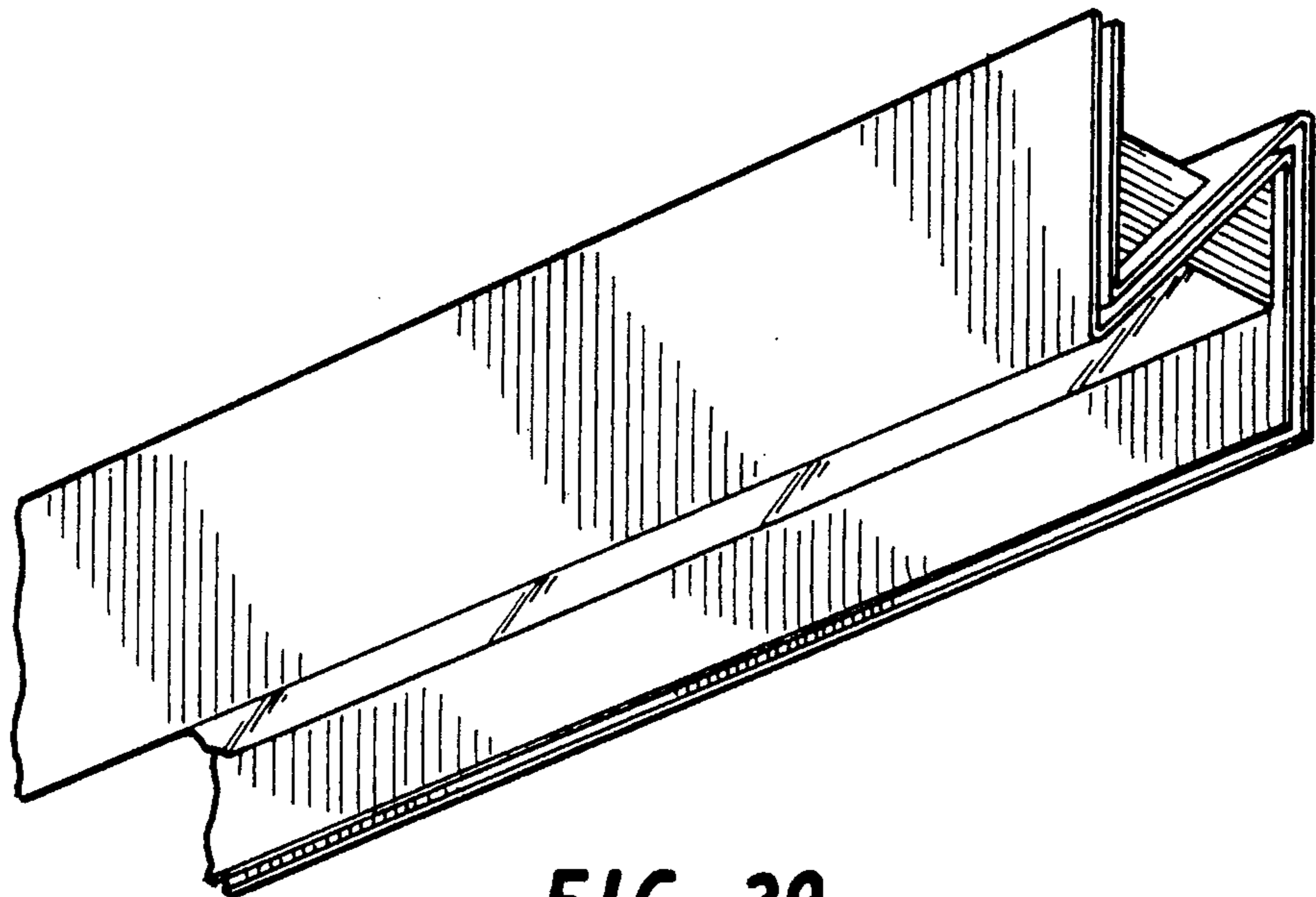
**FIG. 25**



**FIG. 27**

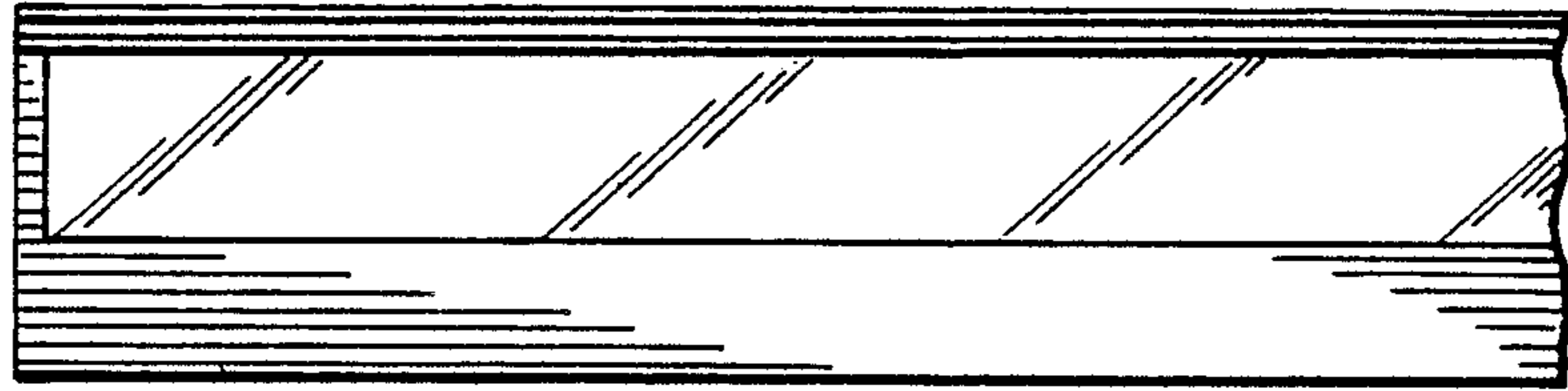


**FIG. 28**

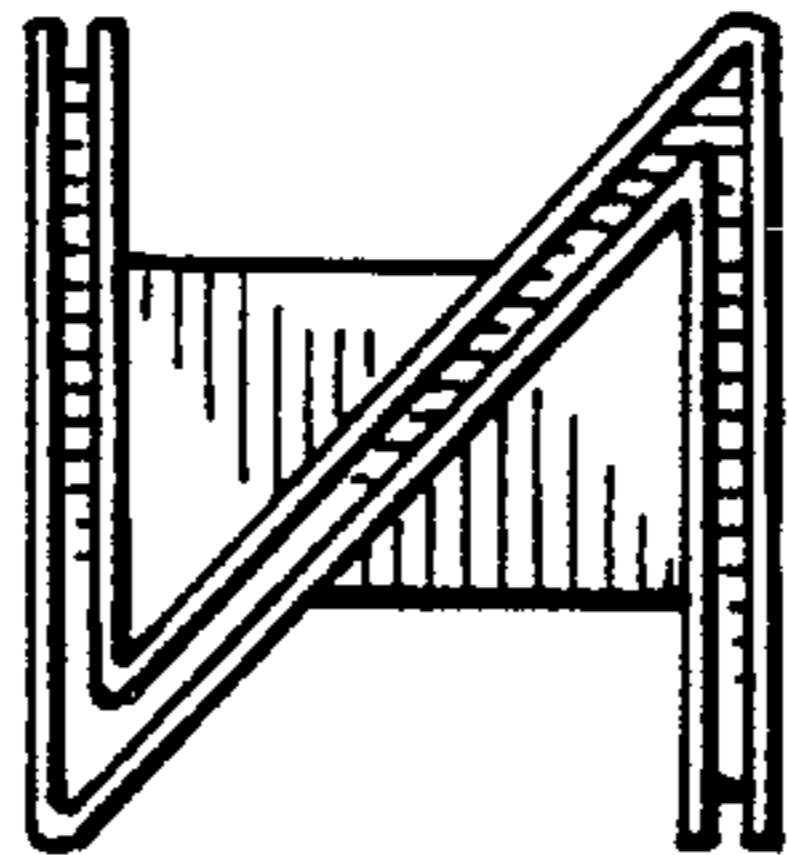


**FIG. 29**

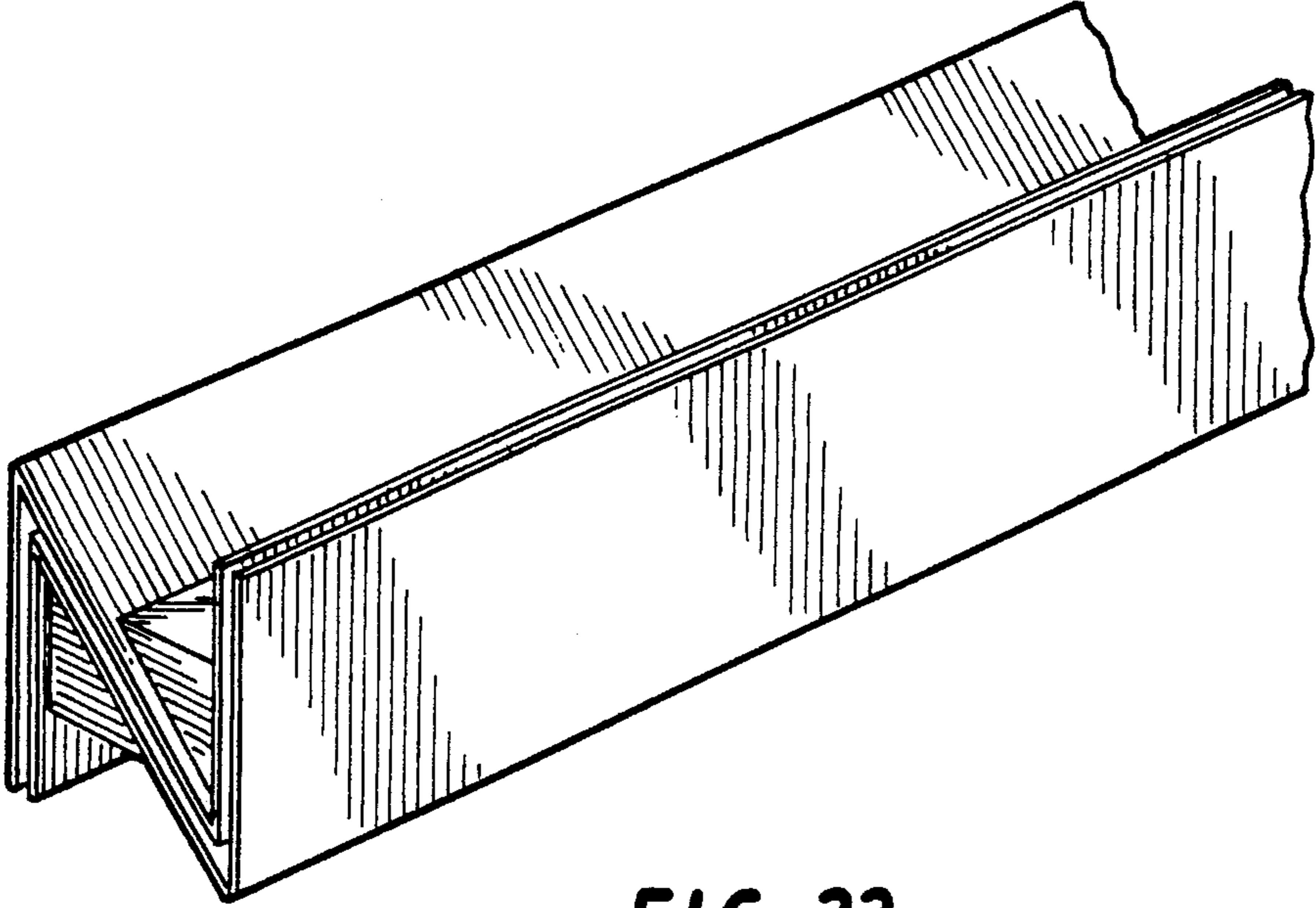




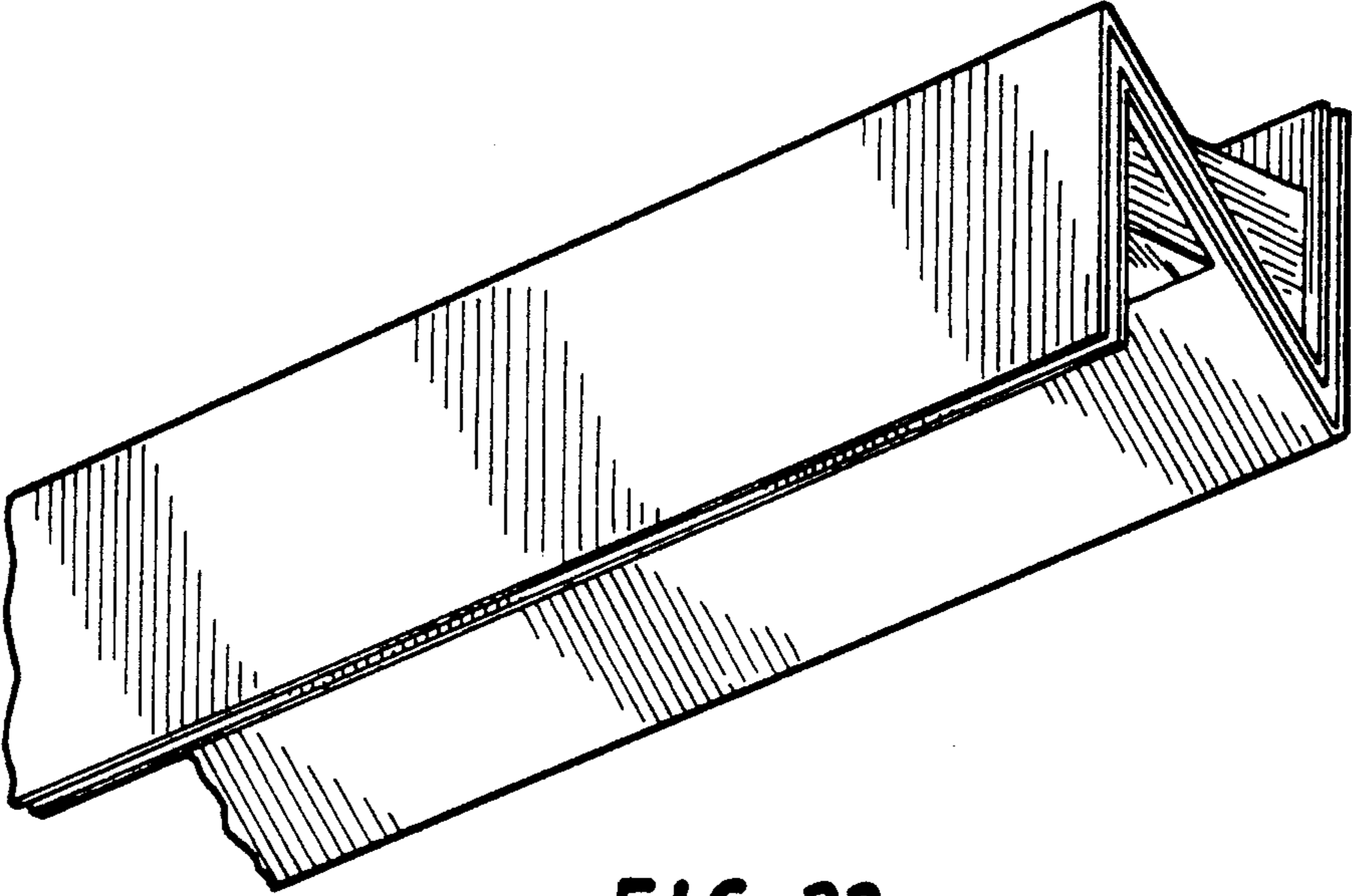
**FIG. 30**



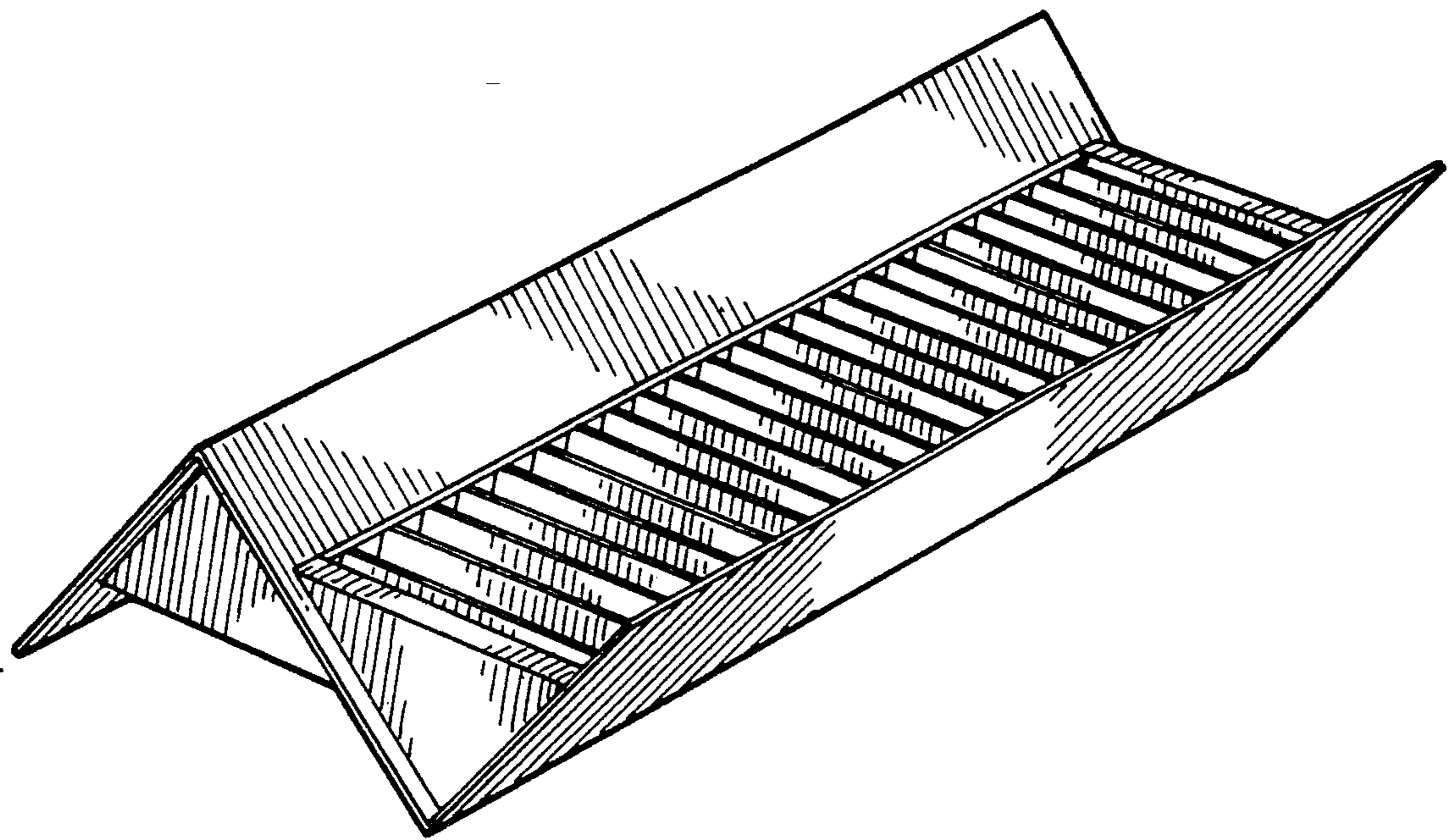
**FIG. 31**



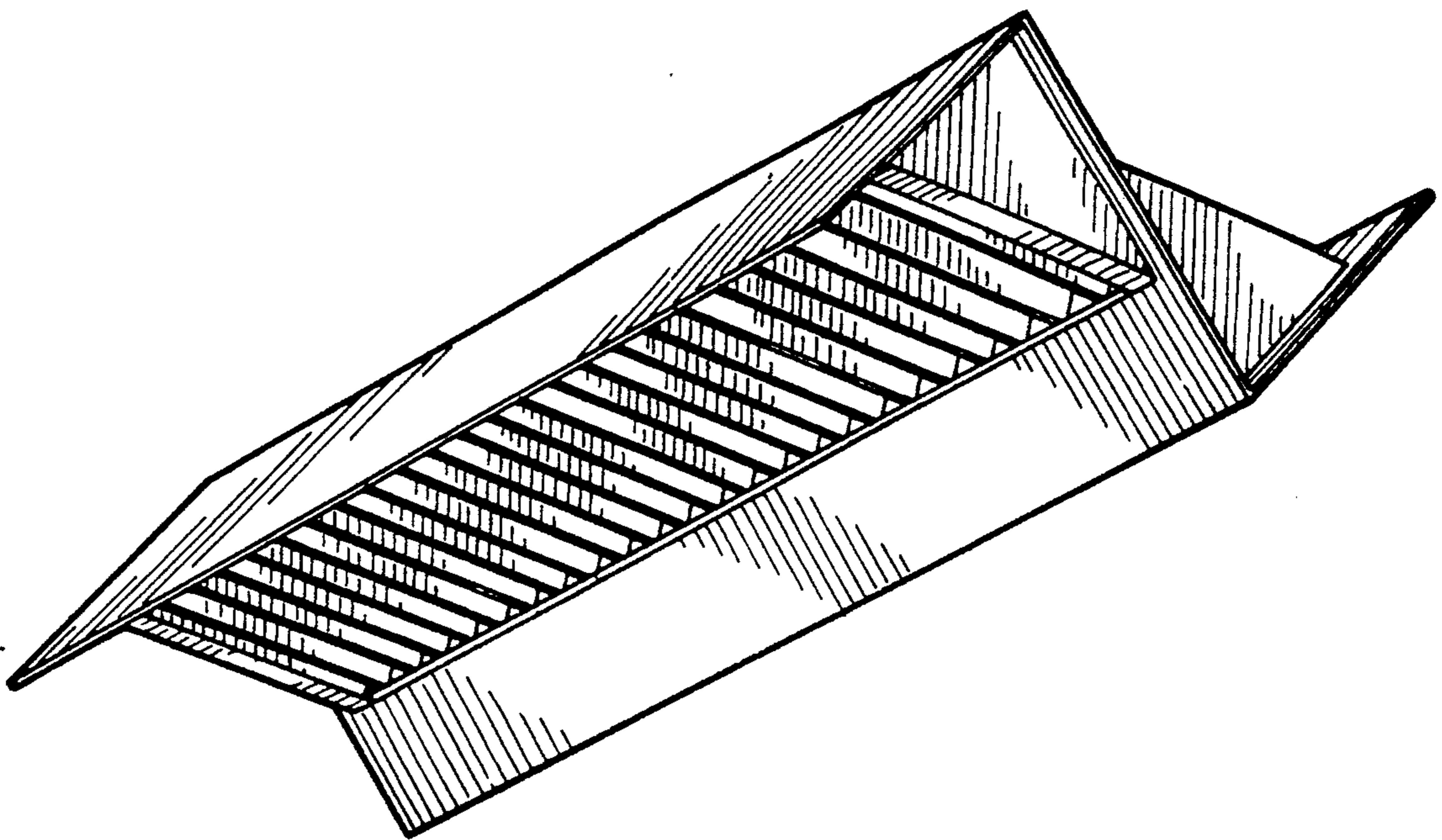
**FIG. 32**



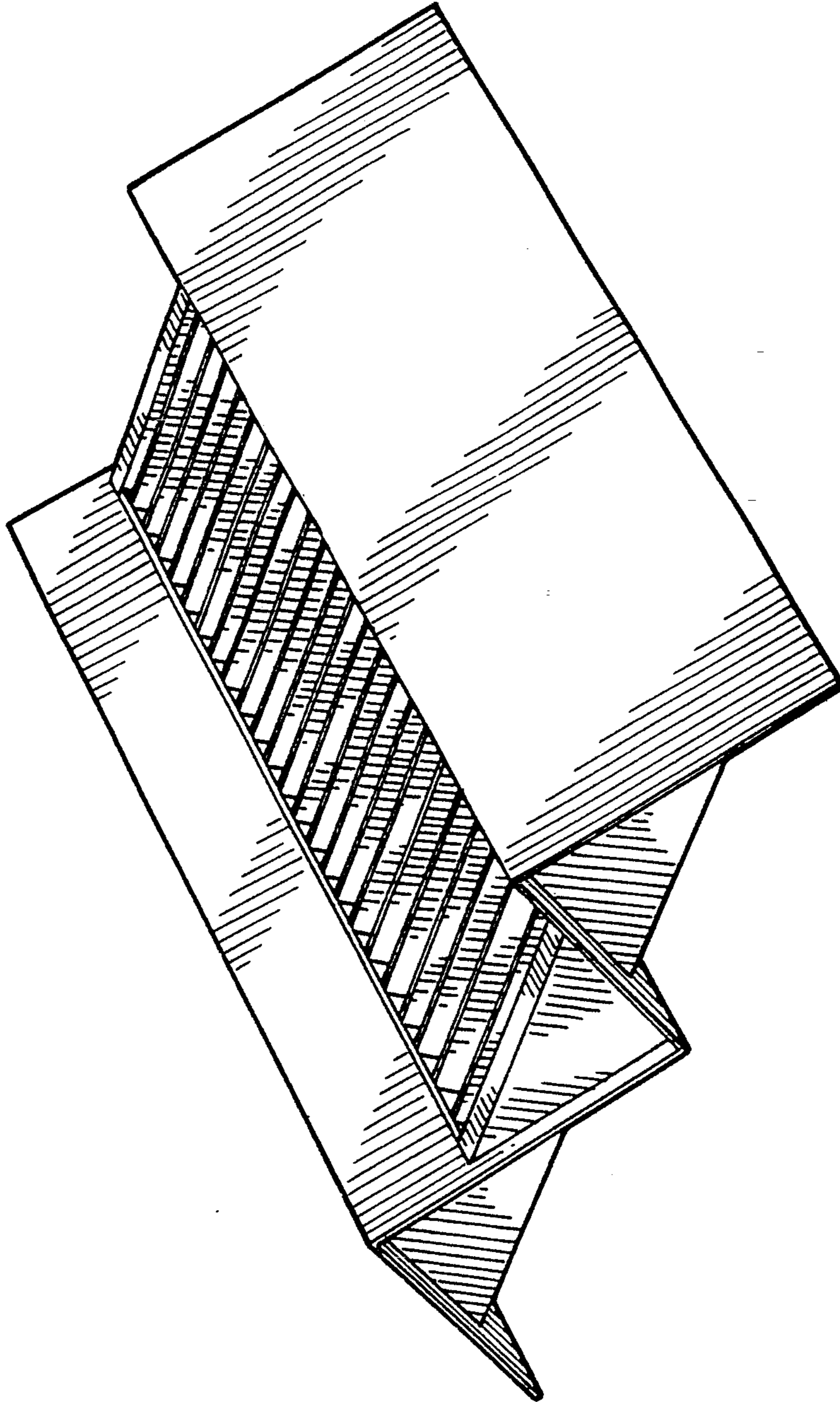
**FIG. 33**



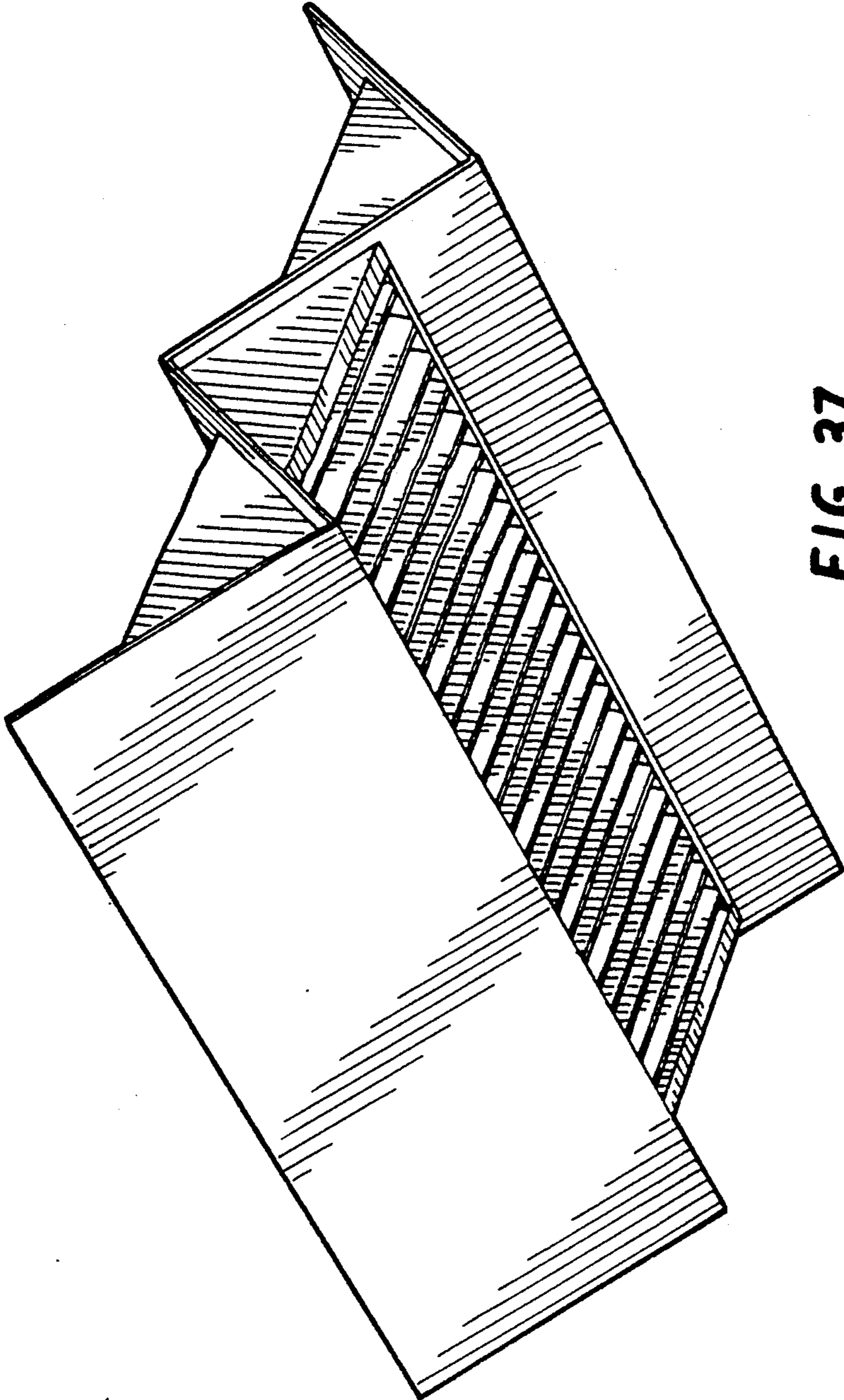
**FIG. 34**



**FIG. 35**



**FIG. 36**



**FIG. 37**

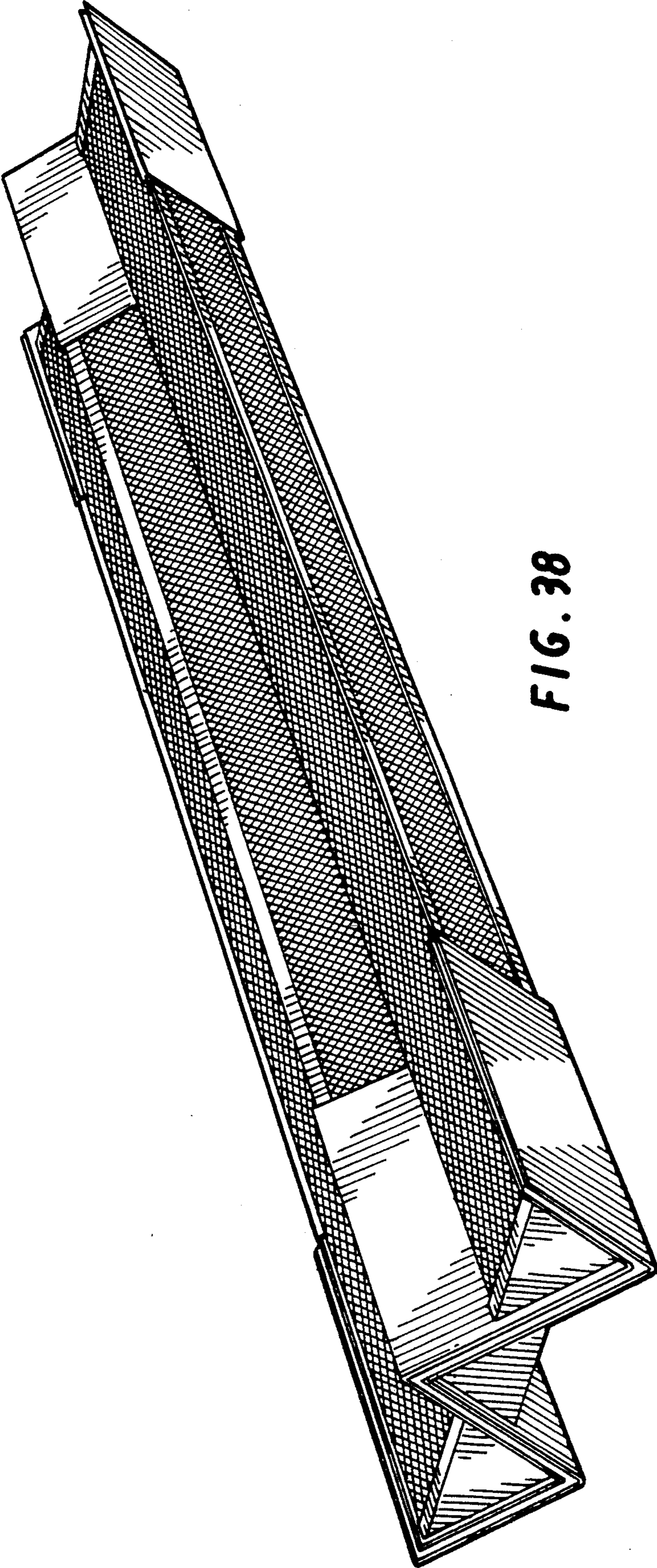


FIG. 38

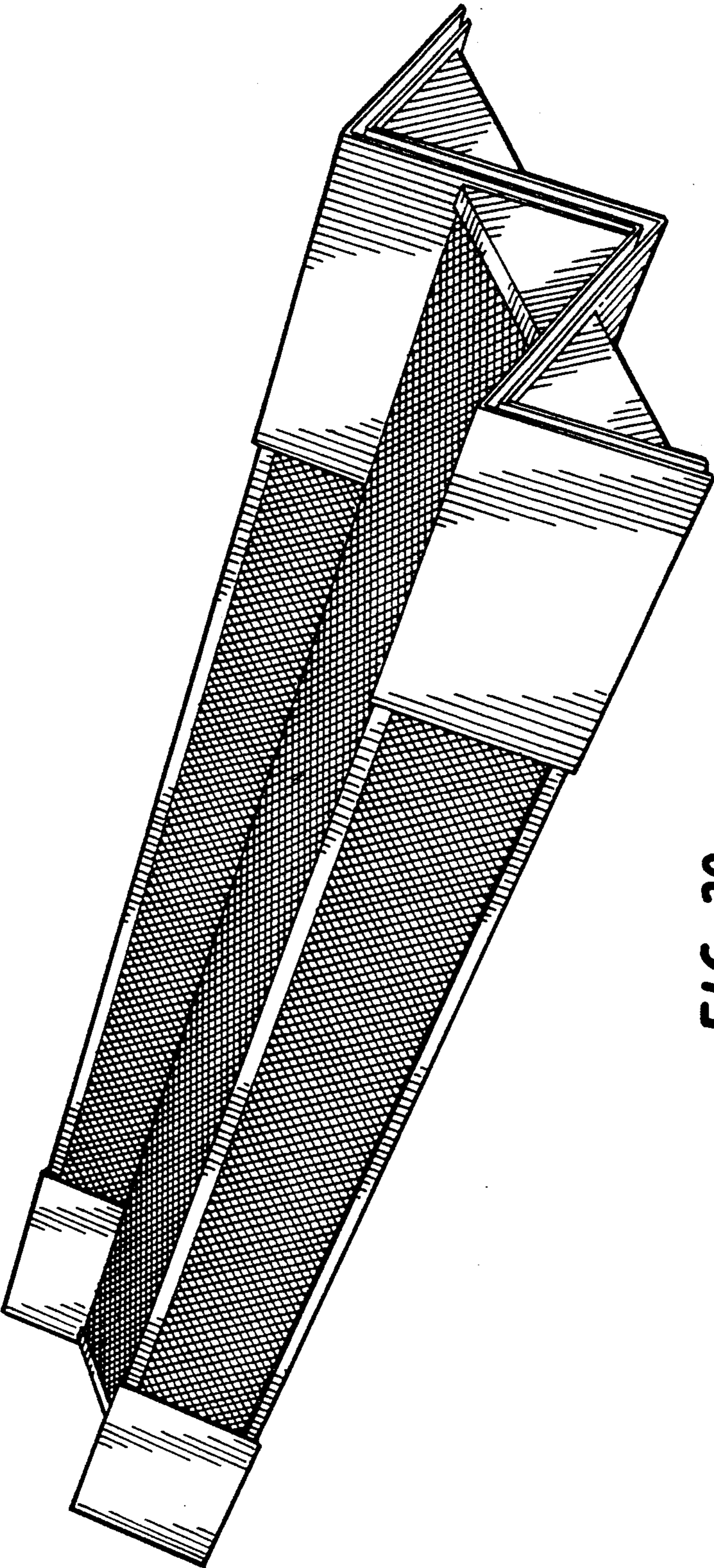
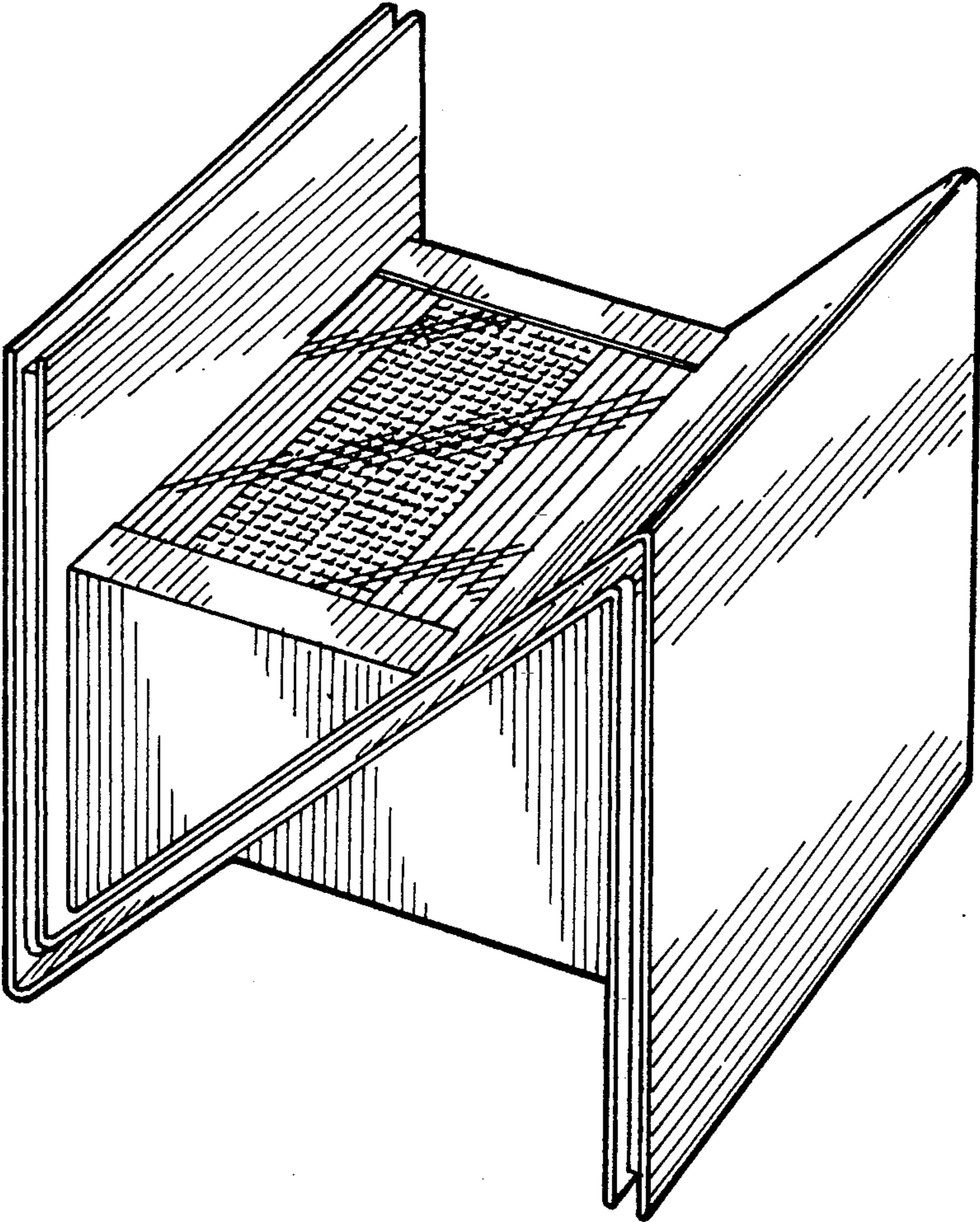
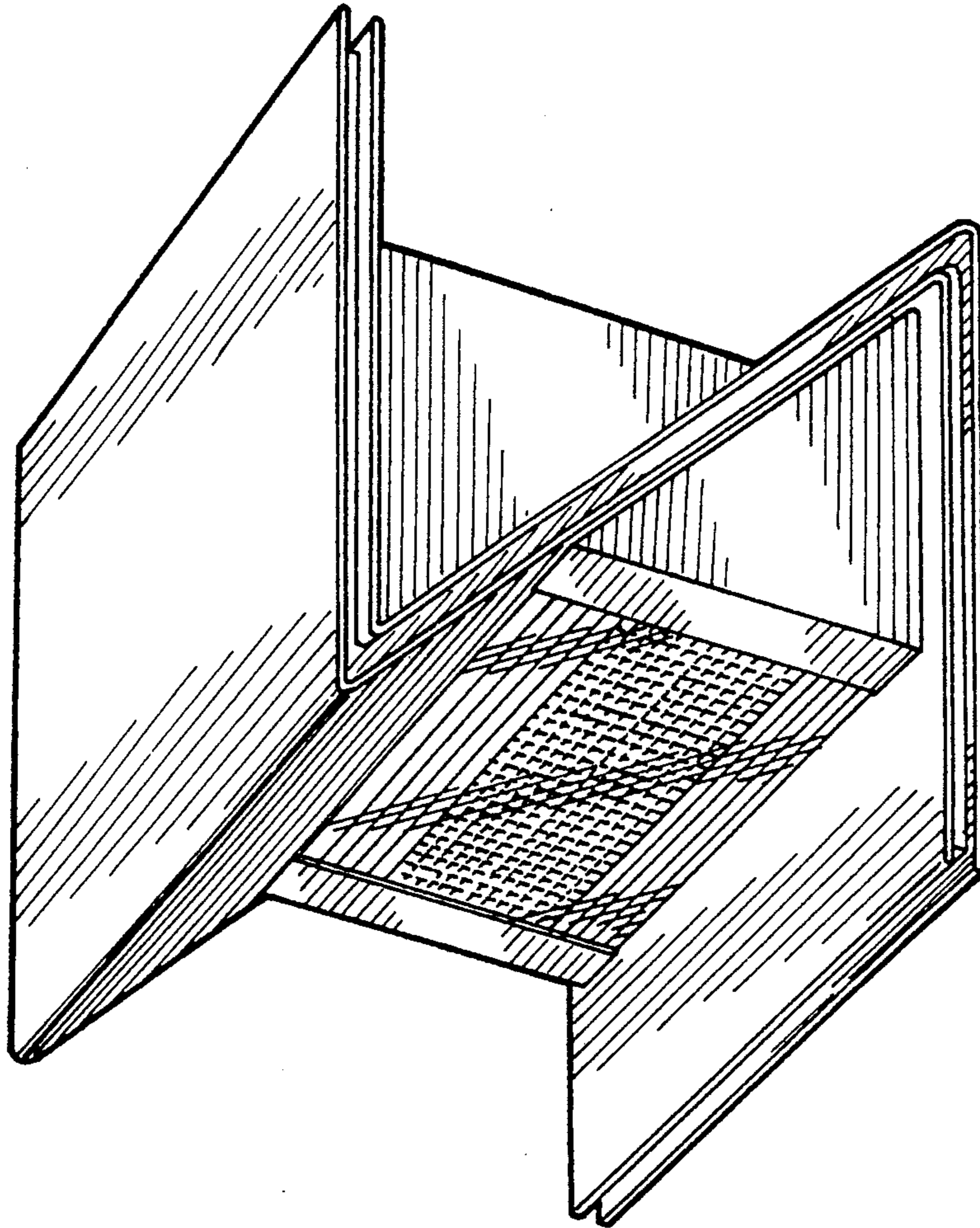


FIG. 39

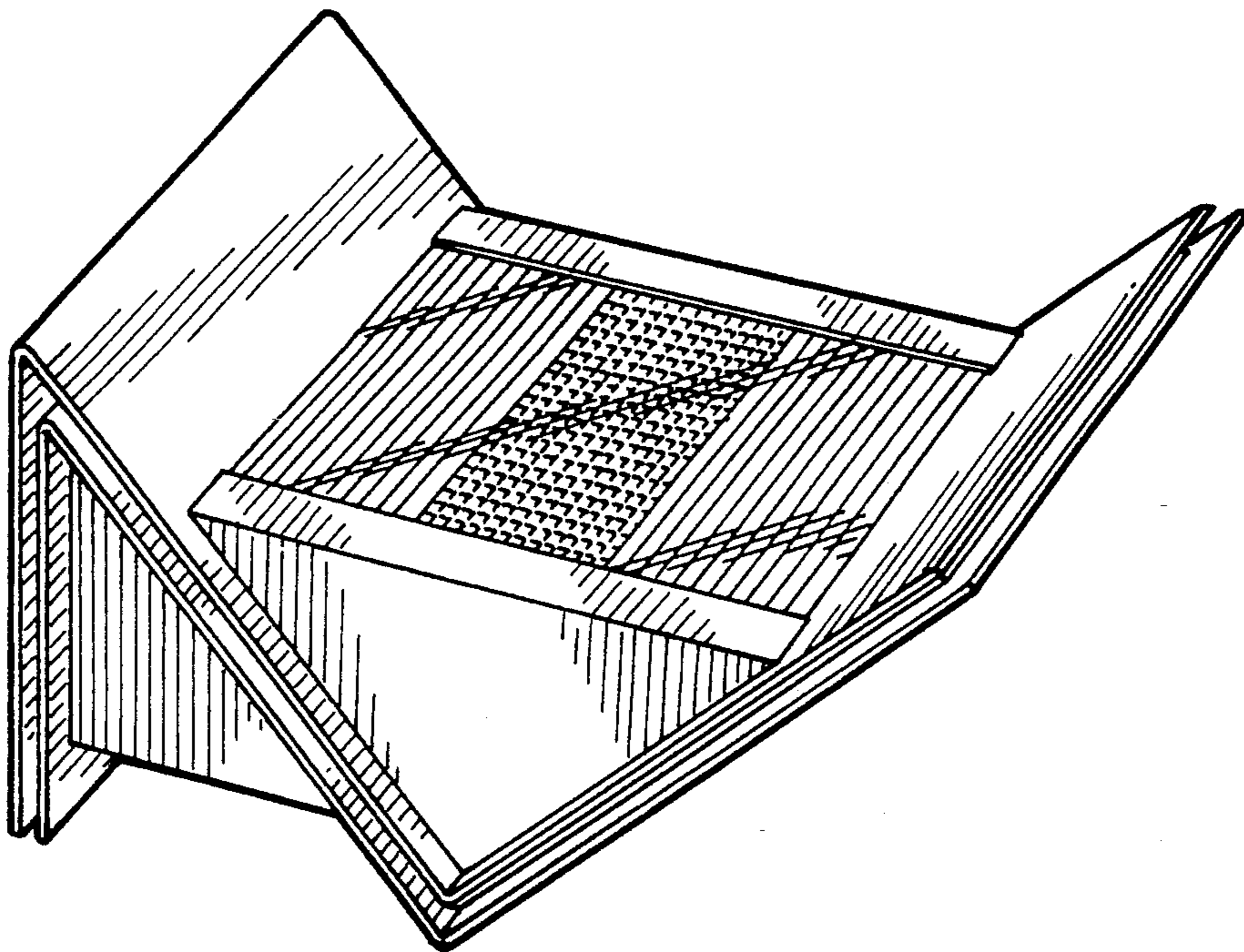




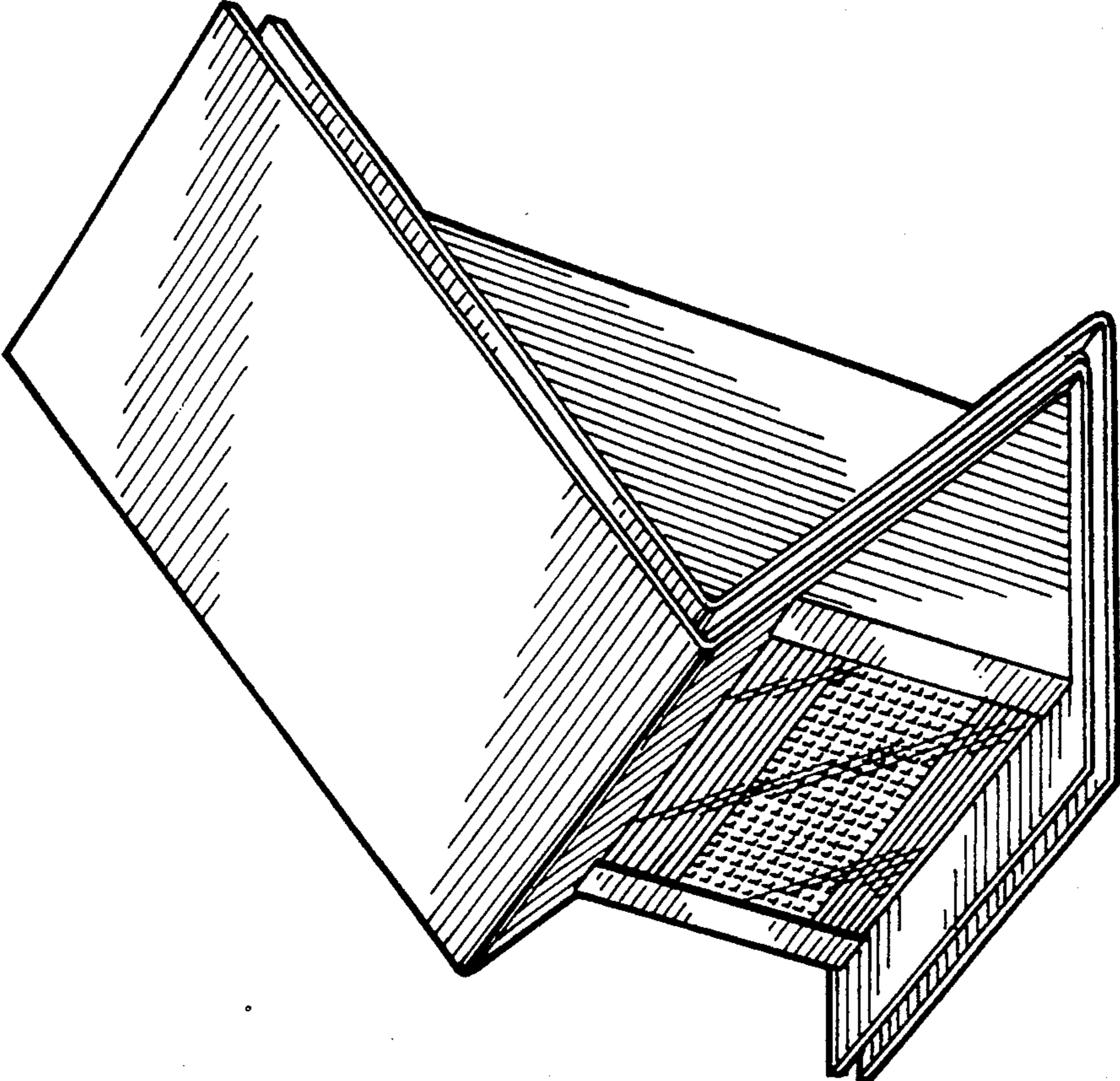
**FIG. 40**



**FIG. 41**



**FIG. 42**



**FIG. 43**