

[54] VEHICLE SECURITY ENCLOSURE

[76] Inventor: Bradley S. Schlachter, P.O. Box 12168, Dallas, Tex. 75225

[\*\*] Term: 14 Years

[21] Appl. No.: 432,666

[22] Filed: Nov. 6, 1989

[52] U.S. Cl. .... D12/156

[58] Field of Search ..... D12/155, 156, 190; D23/403; 296/24.1, 37.6, 37.16, 37.18; 224/42.42; 126/500

4,749,226	6/1988	Heft .....	296/37.6
4,752,096	6/1988	Ishikawa .....	296/37.16
4,776,625	10/1988	Lobanoff et al. ....	296/37.16
4,828,312	5/1989	Kinkel et al. ....	296/37.6
4,867,135	9/1989	Stecker .....	126/500

Primary Examiner—James M. Gandy  
Attorney, Agent, or Firm—Dennis T. Griggs

[57] CLAIM

The ornamental design for a vehicle security enclosure, as shown and described.

DESCRIPTION

FIG. 1 is perspective view of a vehicle security enclosure which illustrates my new design; FIG. 2 is a front elevational view thereof; FIG. 3 is a right side elevational view thereof; FIG. 4 is a left side elevational view thereof; FIG. 5 is a top plan view thereof; FIG. 6 is a bottom plan view thereof; FIG. 7 is a rear perspective view thereof; and FIG. 8 is a front perspective view thereof on a reduced scale as installed on the deck of a vehicle, the broken lines being shown for illustrative purposes only and form no part of the claimed design.

[56] References Cited

U.S. PATENT DOCUMENTS

3,326,596	6/1967	La Spina .....	296/37.16
4,127,301	11/1978	Syrowik .....	296/37.16
4,262,955	4/1981	Duda .....	296/24
4,413,854	11/1983	Hirshberg .....	296/146
4,451,075	5/1984	Canfield .....	224/42.42
4,480,675	11/1984	Berkemeier .....	160/121
4,502,674	3/1985	White et al. ....	296/37.16
4,600,233	7/1986	Boydston .....	296/24.1
4,632,446	12/1986	Douglass .....	296/37.6
4,674,782	6/1987	Helber .....	293/106

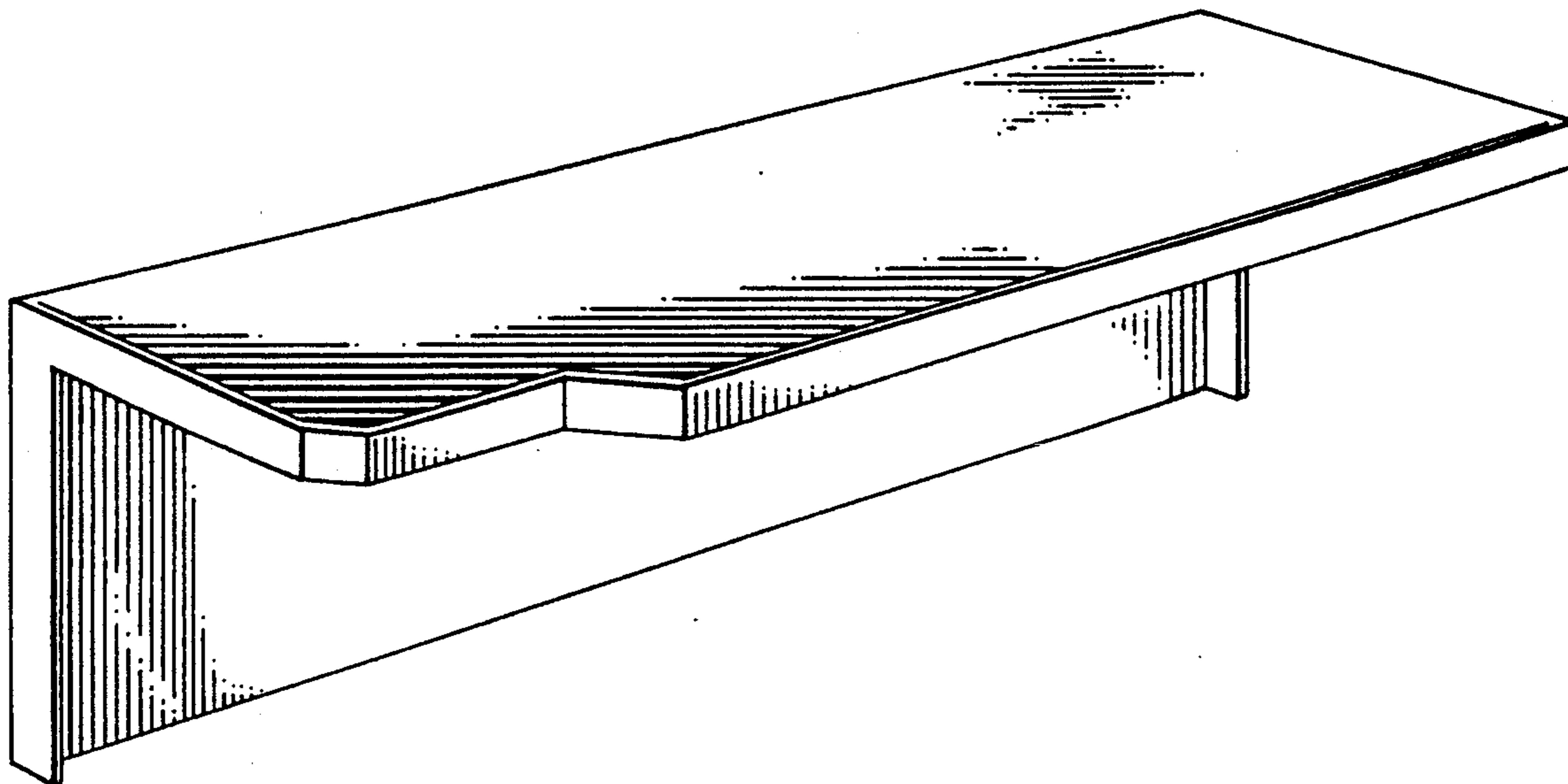

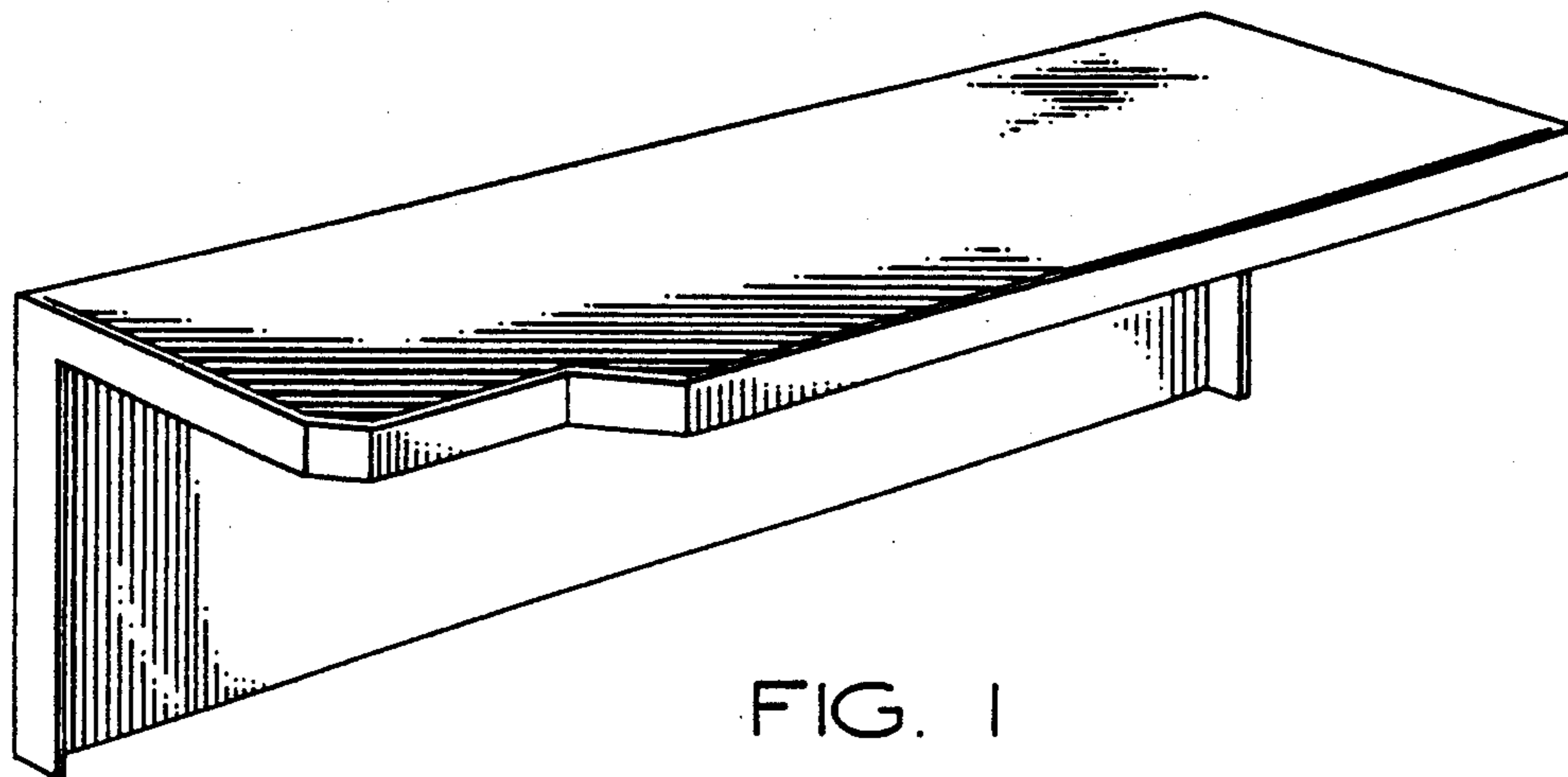

FIG. 1

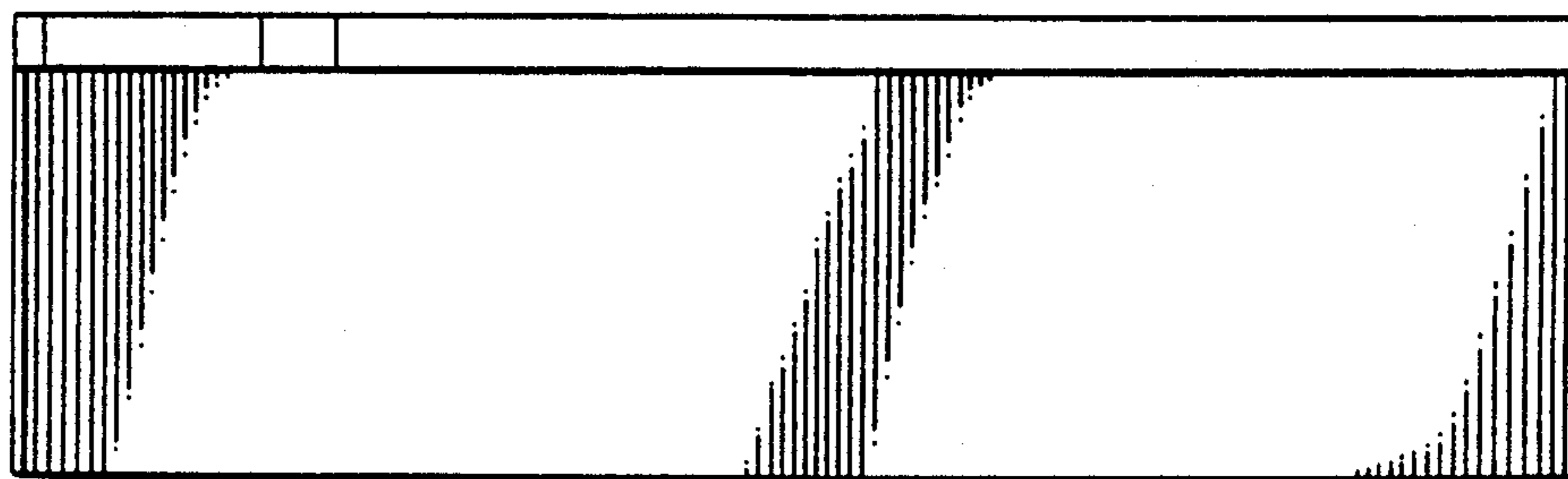

FIG. 2

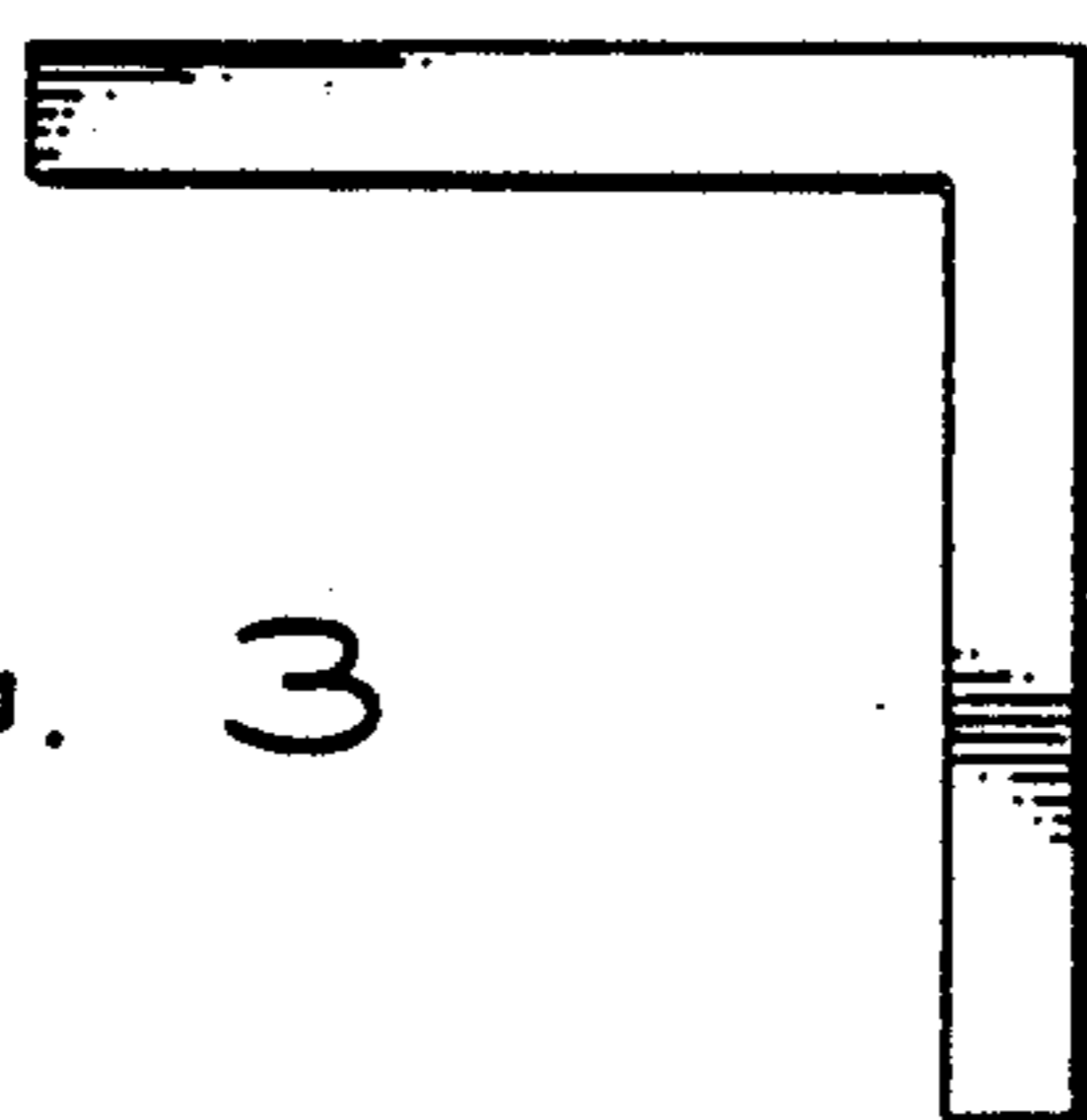

FIG. 3

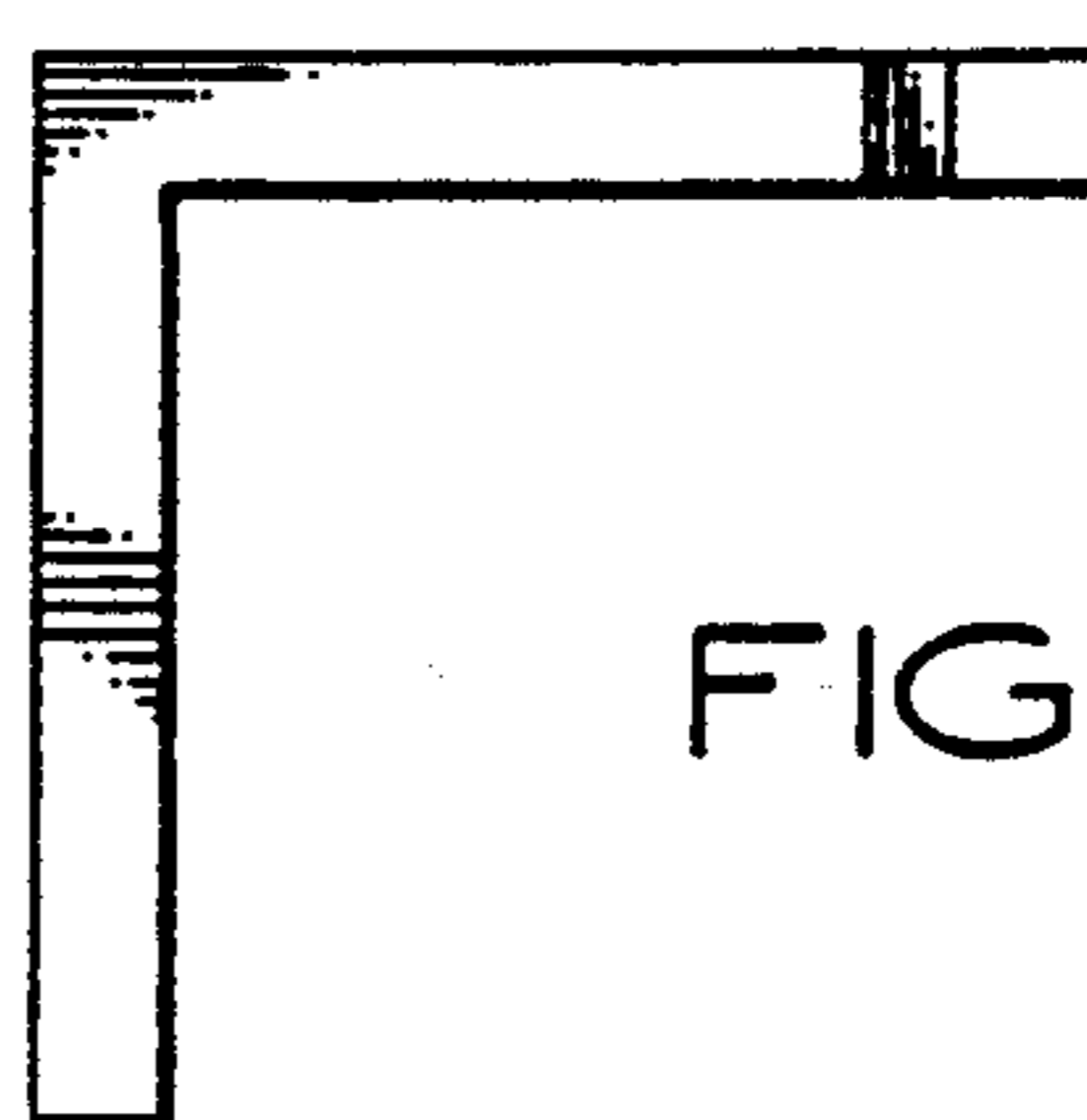

FIG. 4

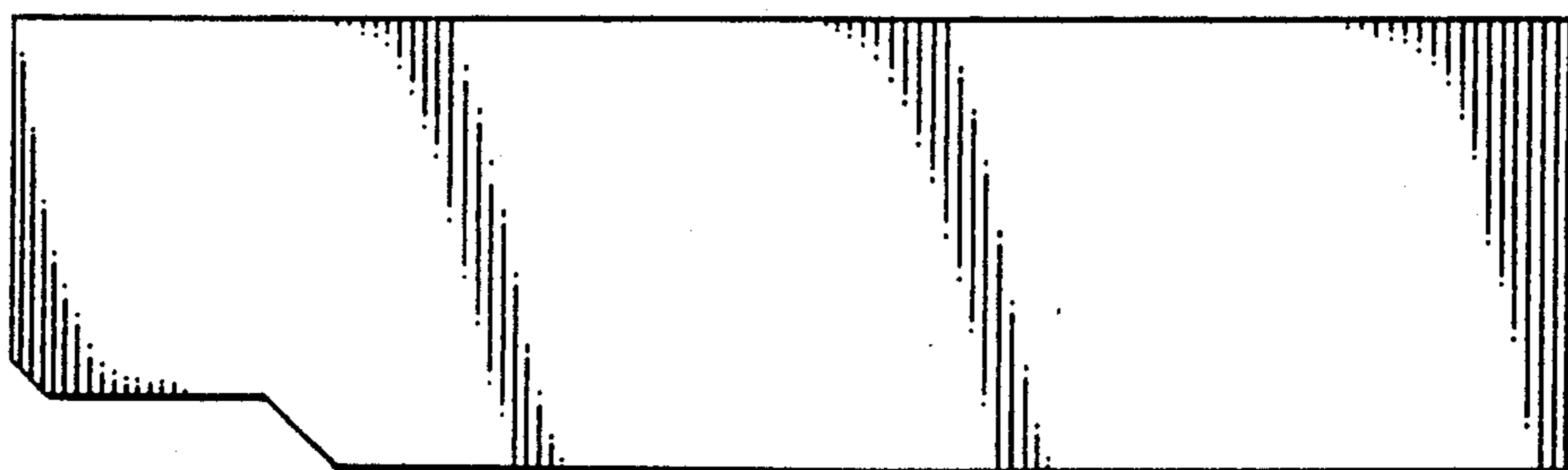

FIG. 5

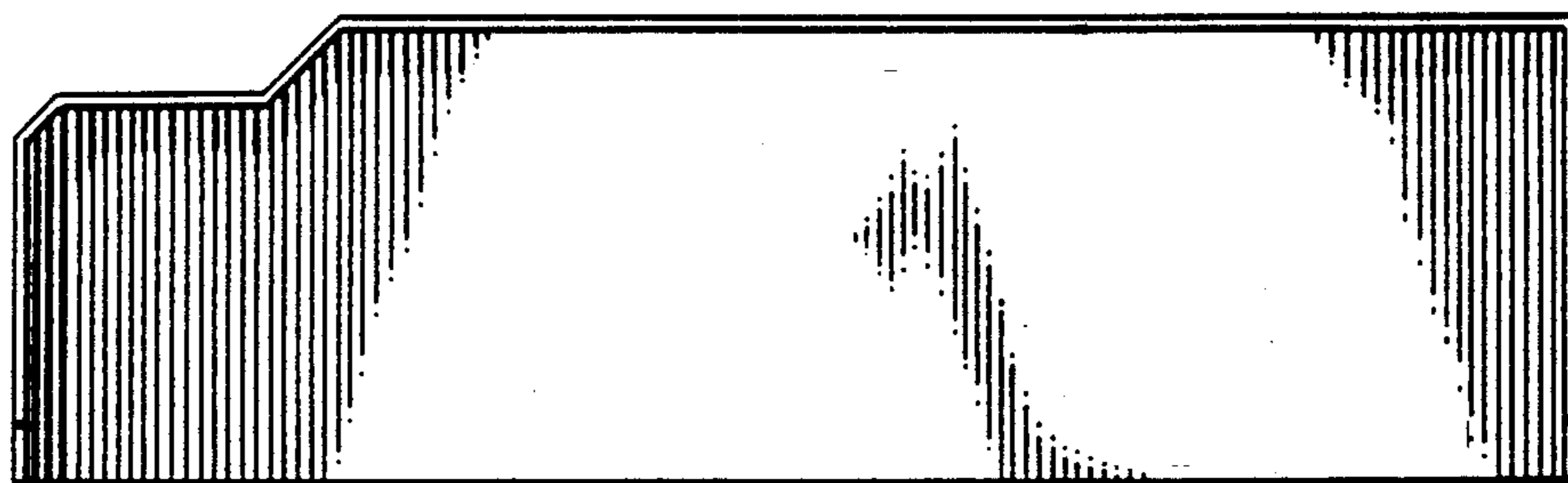

FIG. 6

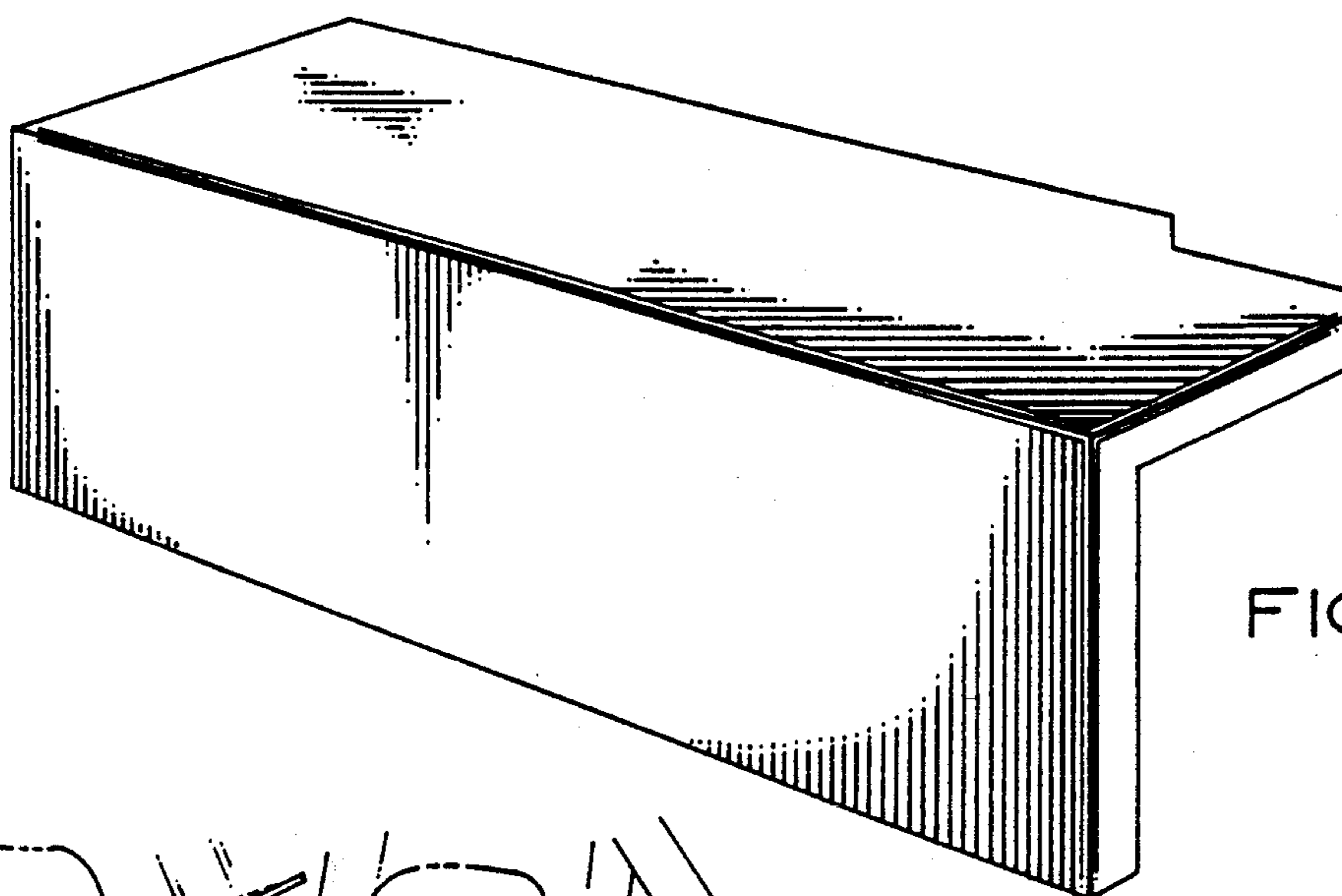

FIG. 7

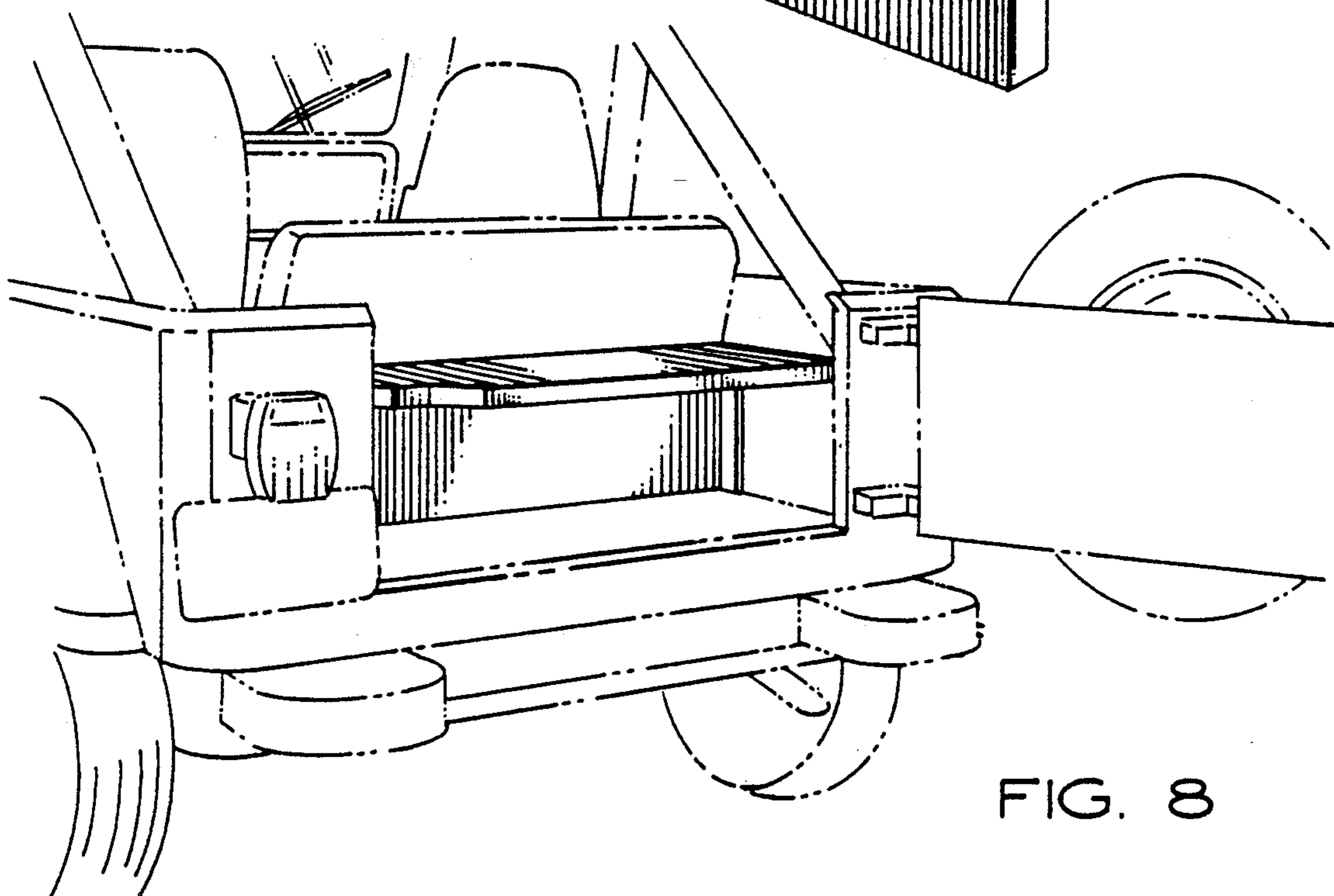

FIG. 8