

[54] TRICYCLE

4,993,733 2/1991 Eilers 280/282

[75] Inventor: John Krieger, Pasadena, Calif.

OTHER PUBLICATIONS

[73] Assignee: Yamaha Hatsudoki Katushiki Kaisha, Iwata, Japan

American Bicyclist & Motorcyclist, Jun. 1987, pp. 29 and 32, H.P.E. Corp., recumbent vehicle & Wiener recumbent vehicle.

[**] Term: 14 Years

American Bicyclist & Motorcyclist, Jun. 1987, p. 36, Wiener's Landspeeder recumbent vehicle.

[21] Appl. No.: 389,553

American Bicyclist & Motorcyclist, Jun. 1987, p. 38, the Tandem recumbent cycle.

[22] Filed: Aug. 4, 1989

[52] U.S. Cl. D12/112

Primary Examiner—James M. Gandy

[58] Field of Search D12/112; 280/267, 282, 280/288.1; 180/210

Assistant Examiner—Melody Brown

Attorney, Agent, or Firm—Ernest A. Beutler

[56] References Cited

[57] CLAIM

U.S. PATENT DOCUMENTS

The ornamental design for a tricycle, as shown.

D. 290,451	6/1987	Engum	D12/112
4,359,231	11/1982	Mulcahy	280/288.1
4,548,421	10/1985	Wiener	280/282
4,572,535	2/1986	Stewart et al.	280/282
4,787,470	11/1988	Badsey	180/210
4,789,173	12/1988	Lofgren et al.	280/282
4,925,200	5/1990	Jones	280/288.1

DESCRIPTION

FIG. 1 is a front and side perspective view of a tricycle showing my new design;

FIG. 2 is a rear and opposite side perspective view thereof;

FIG. 3 is an enlarged bottom plan view thereof.

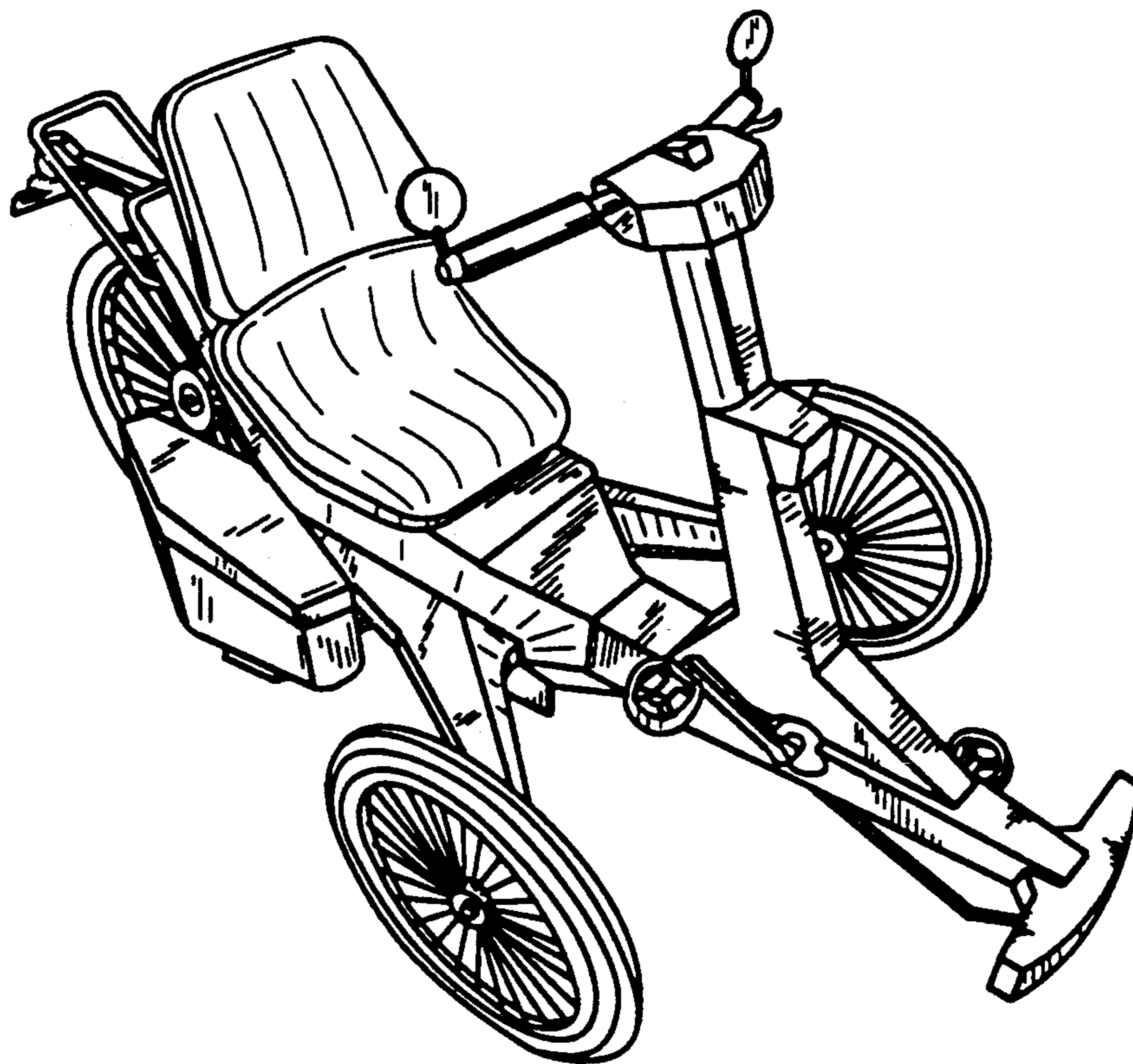

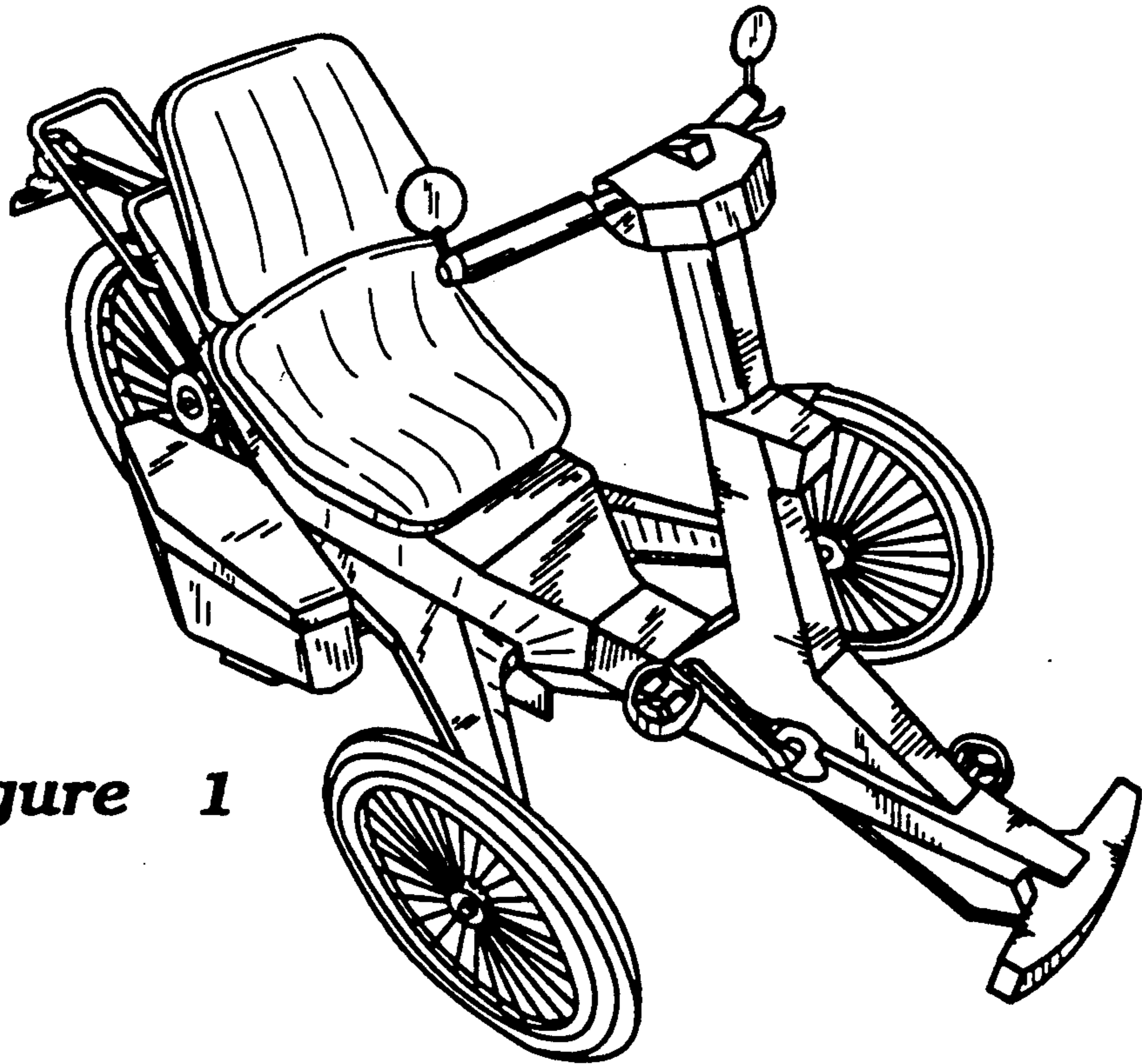

Figure 1

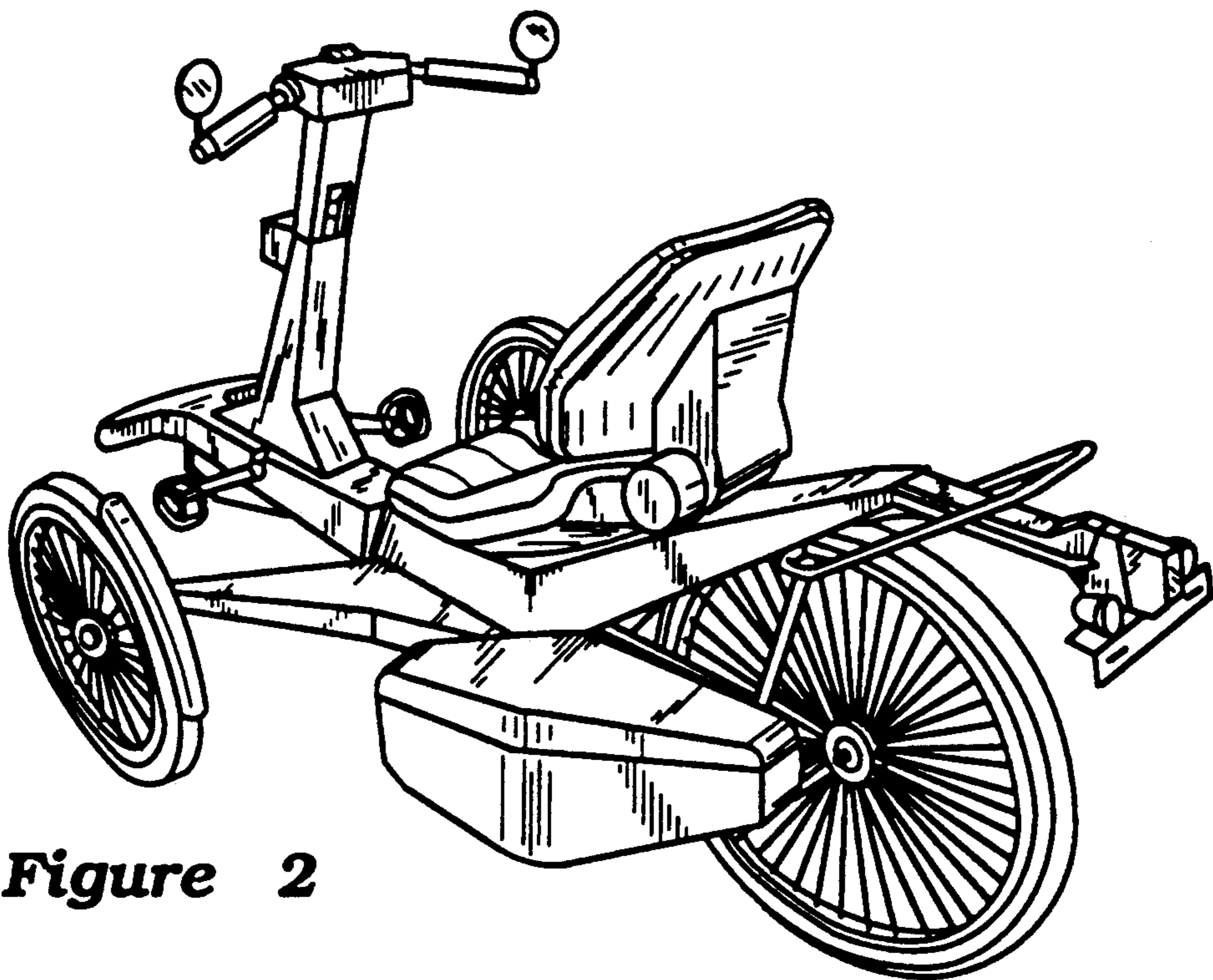

Figure 2

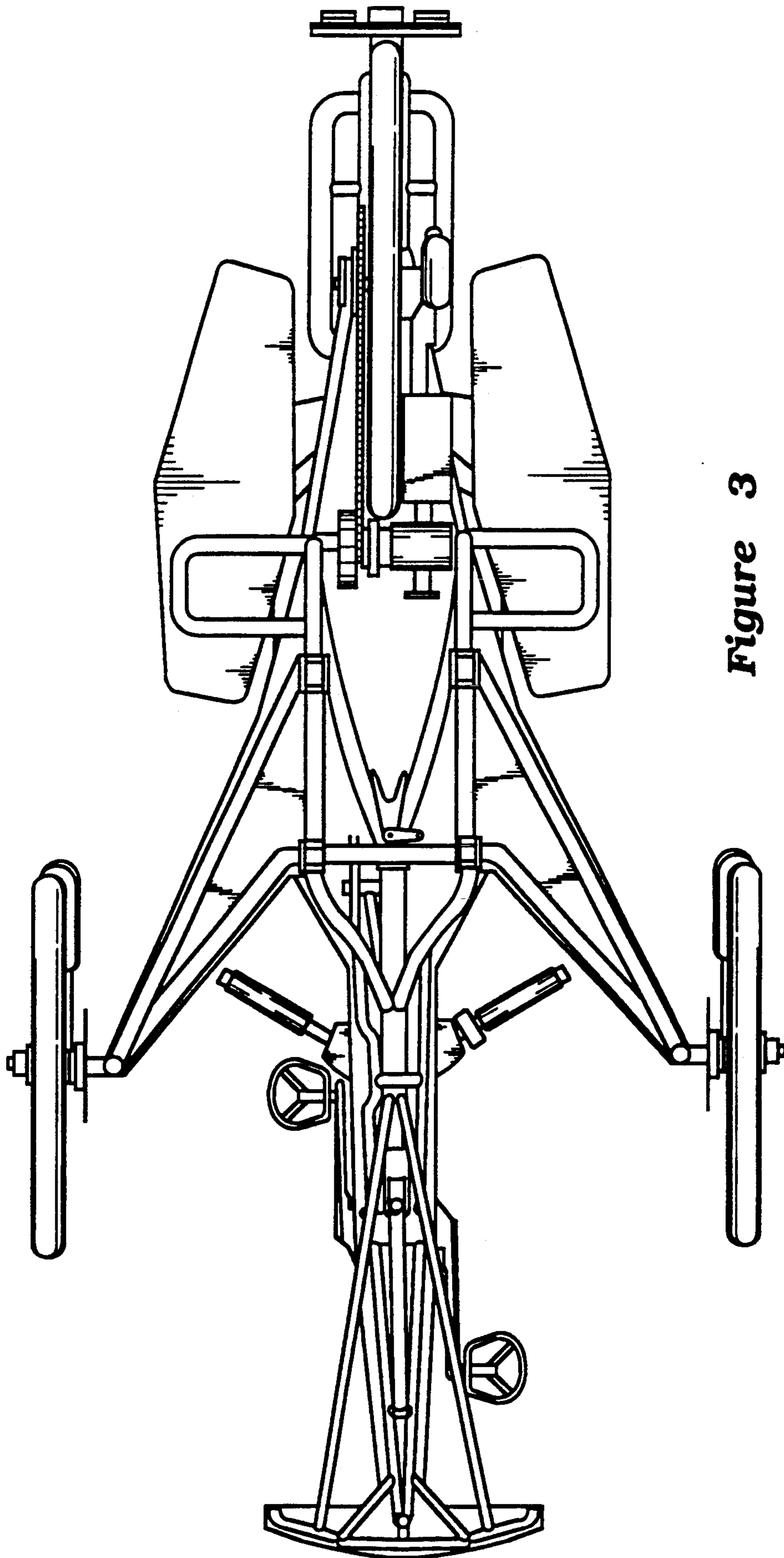

Figure 3