

[54] MOTORCYCLE

[75] Inventor: Akihiko Hikida, Venice, Calif.  
[73] Assignee: Yamaha Hatsudoki Kabushiki Kaisha,  
Iwata, Japan  
[\*\*] Term: 14 Years  
[21] Appl. No.: 385,779

[22] Filed: Jul. 26, 1989  
[52] U.S. Cl. .... D12/110  
[58] Field of Search ..... D12/110, 111; 180/219

[56] References Cited  
U.S. PATENT DOCUMENTS

D. 200,753	3/1965	Ryan	.....	D12/111
D. 237,701	11/1975	Vachon	.....	D12/111
D. 241,527	9/1976	Kojo	.....	D12/110
D. 302,801	8/1989	Lacroix	.....	D12/110

OTHER PUBLICATIONS

American Bicyclist & Motorcyclist, Dec. 1988, p. 85,  
1989 Jawa Moped.  
American Bicyclist & Motorcyclist, Sep./Oct. 1988, p.  
107, Motormaria model (Sebring) moped.  
American Bicyclist & Motorcyclist, Aug. 1986, p. 72,  
the Derbi SL & SLEC mopeds.  
Matahuti of America Brochure, Feb. 1980, p. 2, the  
Ronuno Junior Cycle.  
*Primary Examiner*—James M. Gandy  
*Assistant Examiner*—Melody N. Brown  
*Attorney, Agent, or Firm*—Ernest A. Beutler

[57] CLAIM

The ornamental design for a motorcycle, as shown.

DESCRIPTION

FIG. 1 is a front and side perspective view of a motor-  
cycle showing my new design;  
FIG. 2 is a side elevational view thereof;  
FIG. 3 is a side elevational view of the other side  
thereof;  
FIG. 4 is a front elevation view thereof;  
FIG. 5 is a rear elevation view thereof;  
FIG. 6 is a top plan view thereof.

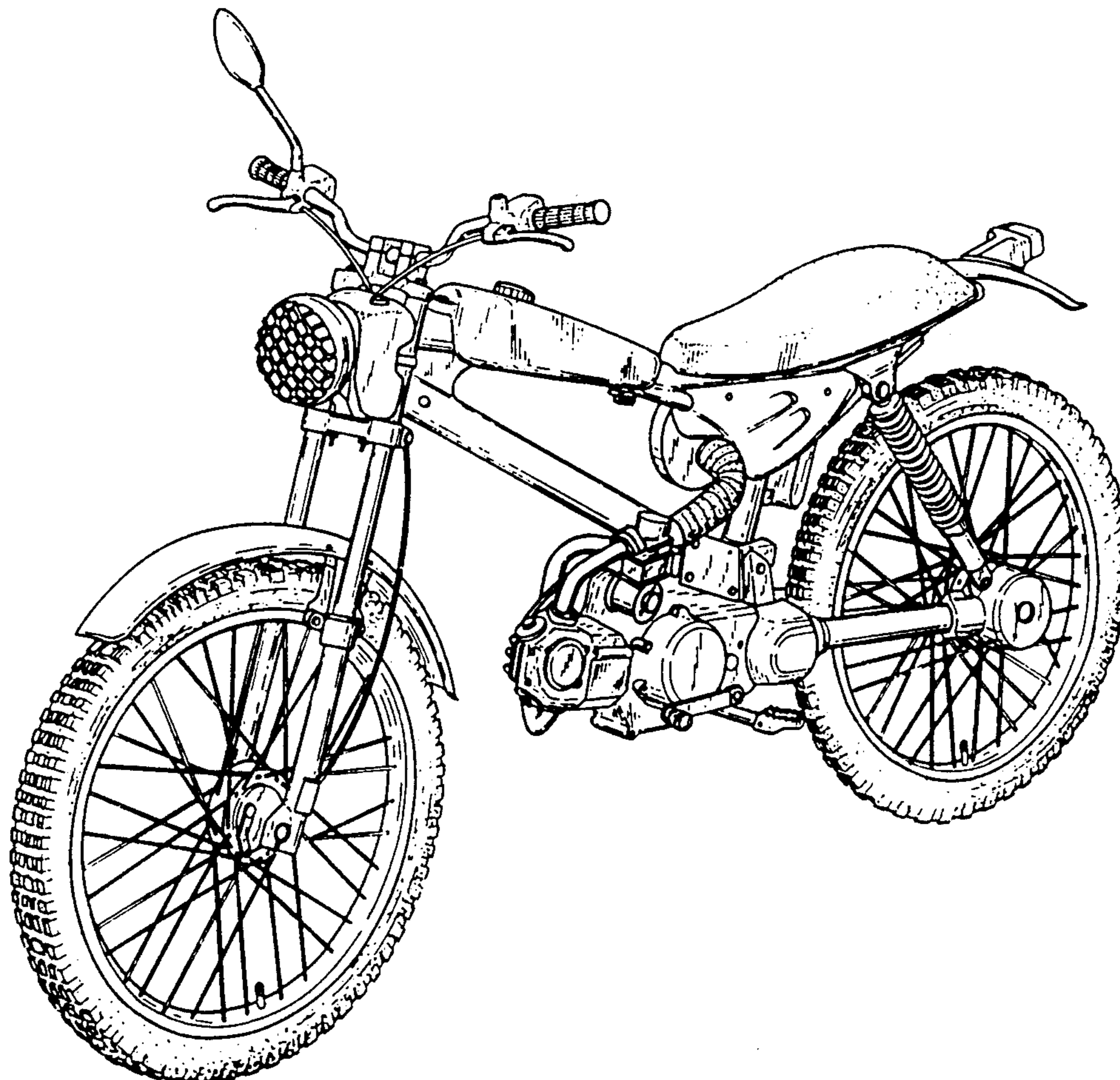

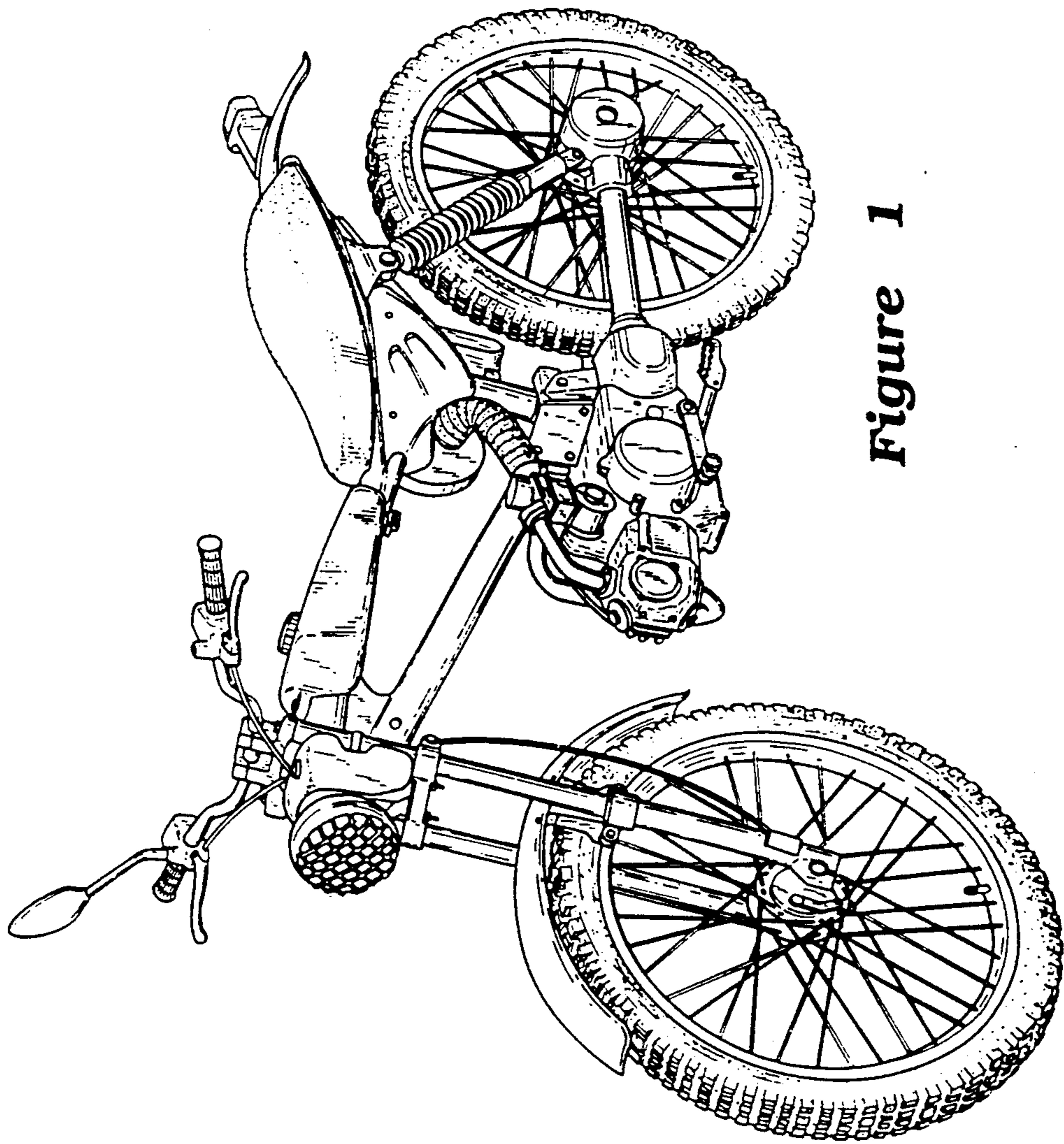

Figure 1

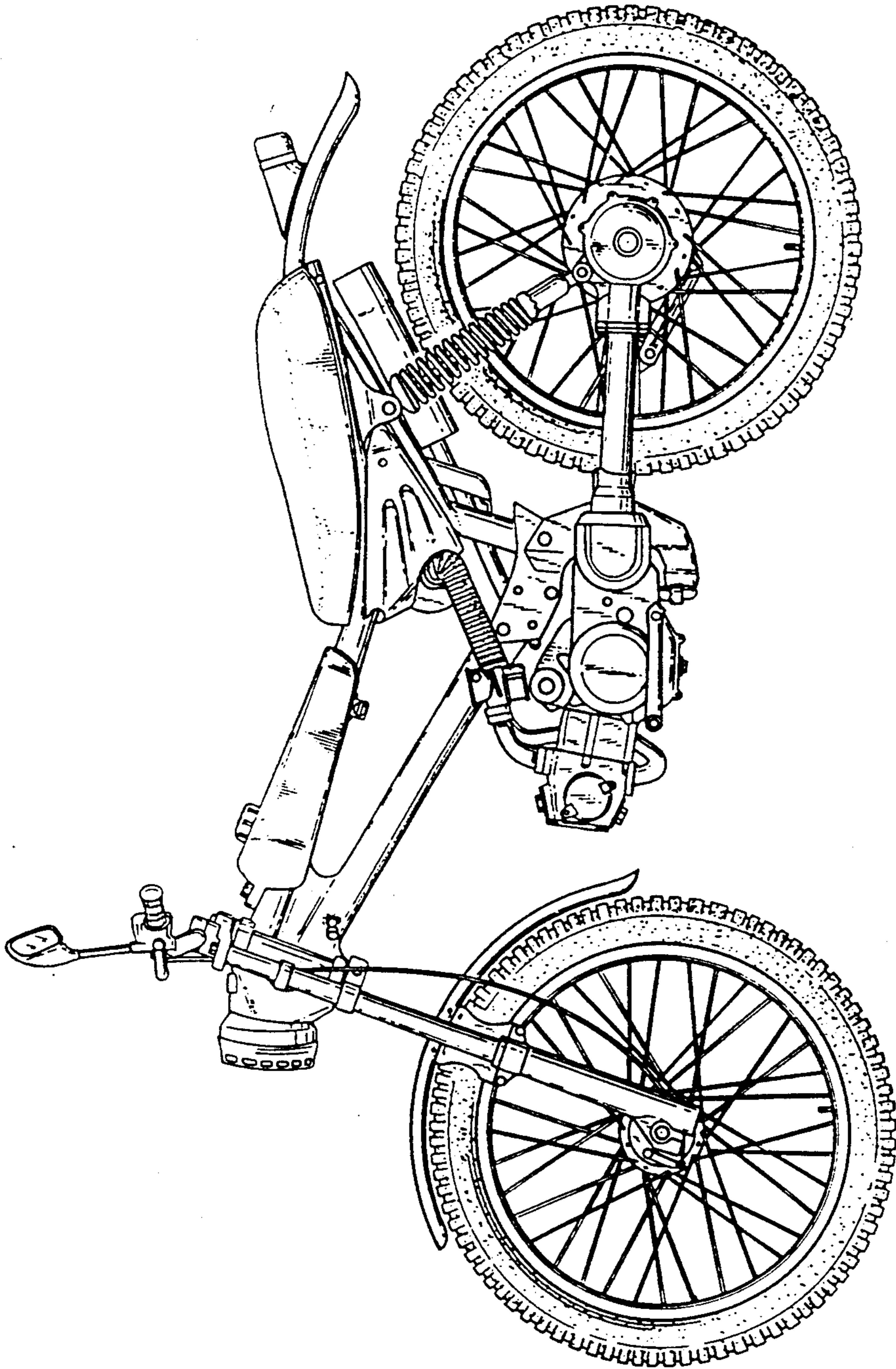

Figure 2

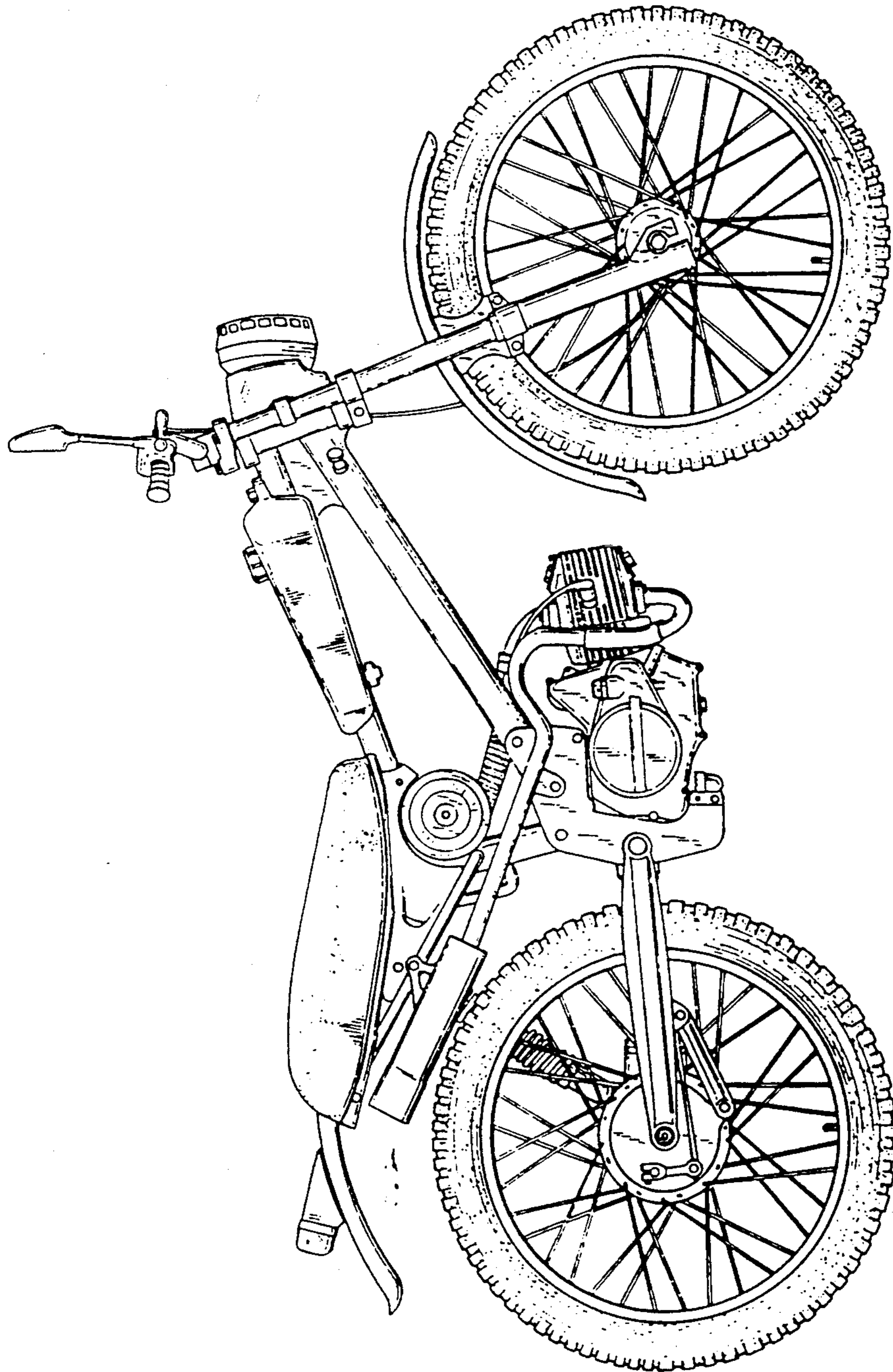

Figure 3

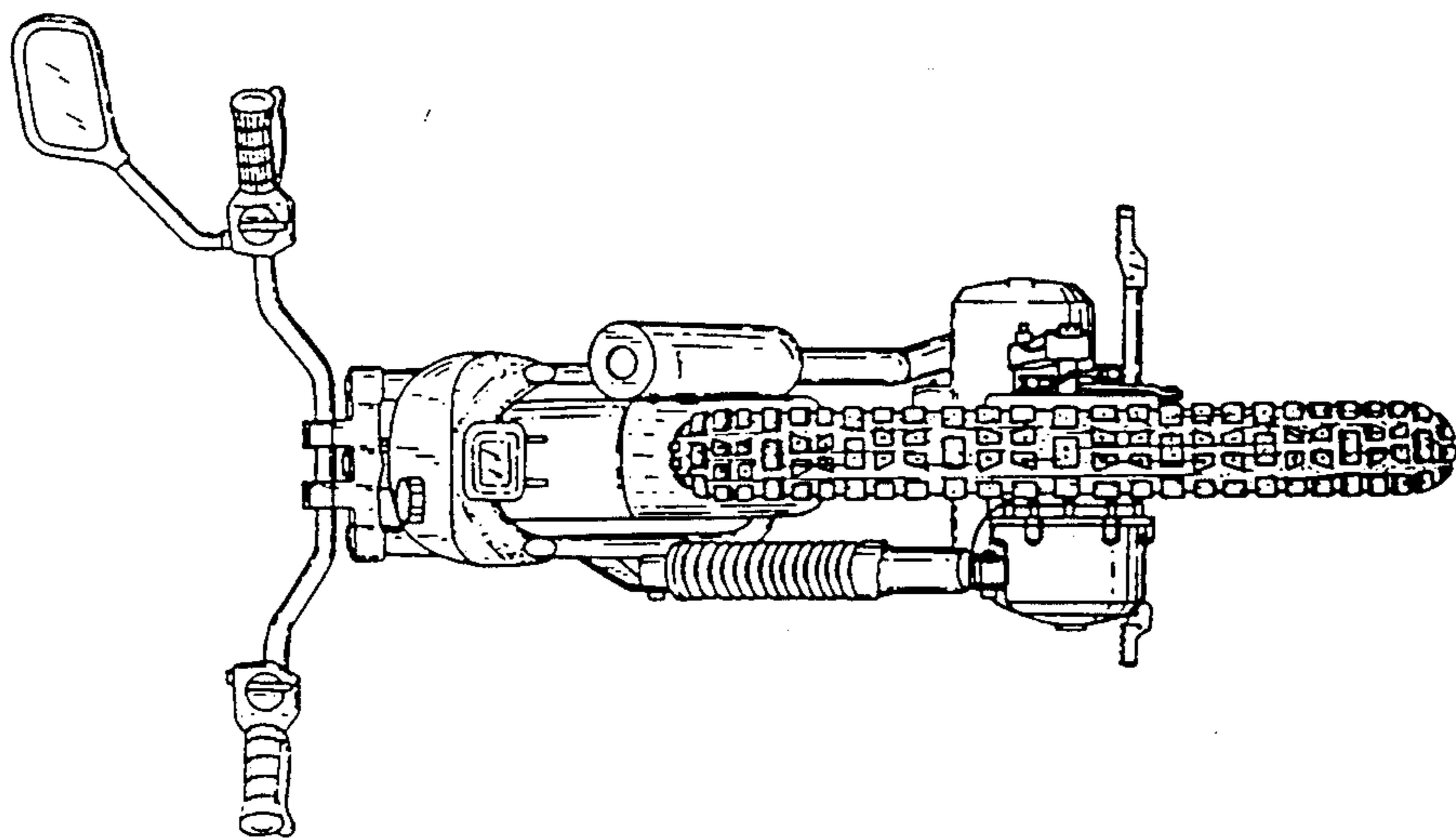

Figure 5

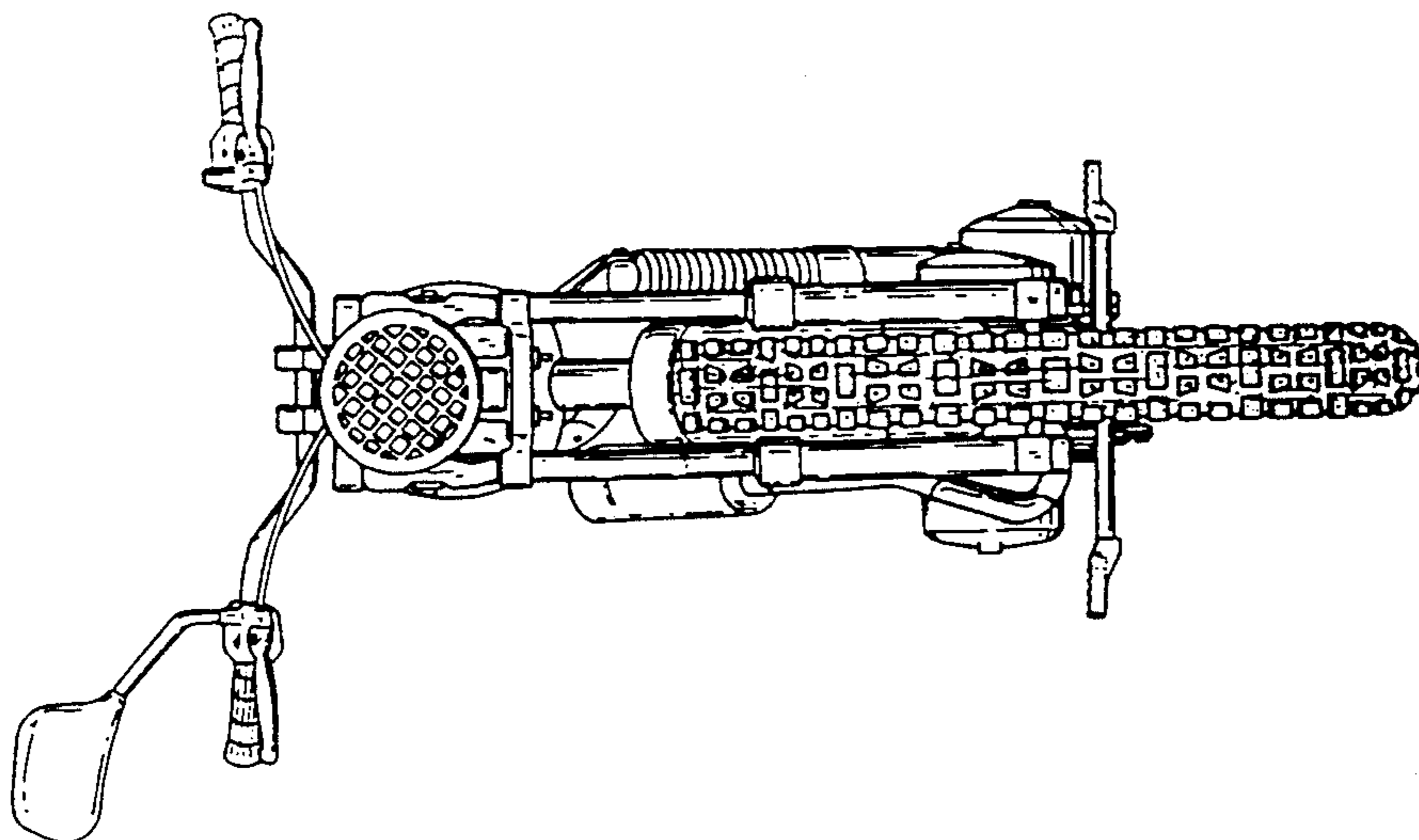

Figure 4

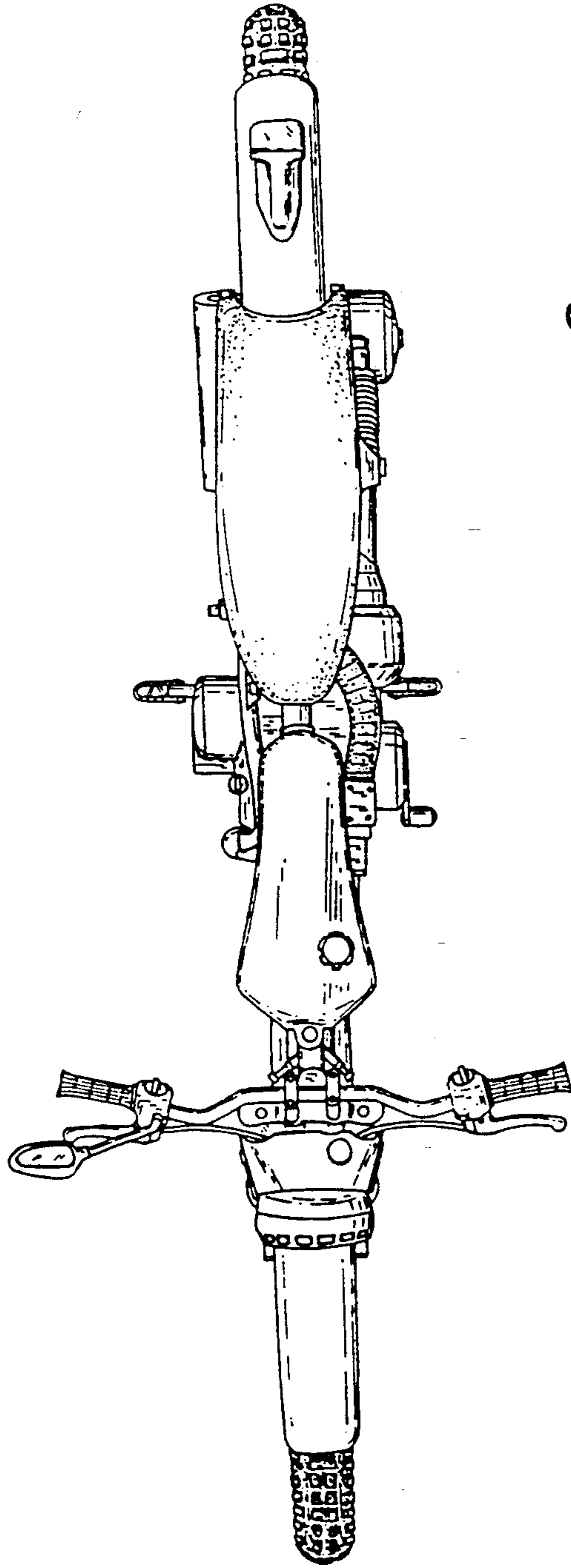

Figure 6