

[54] HYDRAULIC OIL TANK FOR USE IN CEMENT TRUCKS

[75] Inventors: William L. Loefke, Kasson; Terry D. Grabow, Red Wing, both of Minn.

[73] Assignee: McNeilus Truck & Manufacturing, Inc., Dodge Center, Minn.

[**] Term: 14 Years

[21] Appl. No.: 471,130

[22] Filed: Jan. 26, 1990

[52] U.S. Cl. D23/205

[58] Field of Search D23/200, 202-206; 220/565, 1.5, 4.12, DIG. 12, DIG. 14; 366/60-62; 215/1 R, 1 C

[56] References Cited

U.S. PATENT DOCUMENTS

- D. 162,118 2/1951 Bausenbach D23/205
- D. 212,417 10/1968 Glover D23/205

- D. 243,455 2/1977 Verini D23/205
- D. 295,673 5/1988 Anderson et al. D23/205 X
- 4,147,269 4/1979 Wertz 220/565
- 4,387,995 6/1983 Routson 366/60 X

Primary Examiner—Susan J. Lucas
 Assistant Examiner—M. H. Tung
 Attorney, Agent, or Firm—Merchant, Gould, Smith, Edell, Welter & Schmidt

[57] CLAIM

The ornamental design for an hydraulic oil tank for use in cement trucks, as shown and described.

DESCRIPTION

FIG. 1 is a top right perspective view of a hydraulic oil tank for use in cement trucks showing our new design; FIG. 2 is a side elevational view thereof; FIG. 3 is an opposite side elevational view thereof; FIG. 4 is a front elevational view thereof; FIG. 5 is a rear elevational view thereof; FIG. 6 is a top plan view thereof; FIG. 7 is a bottom plan view thereof.

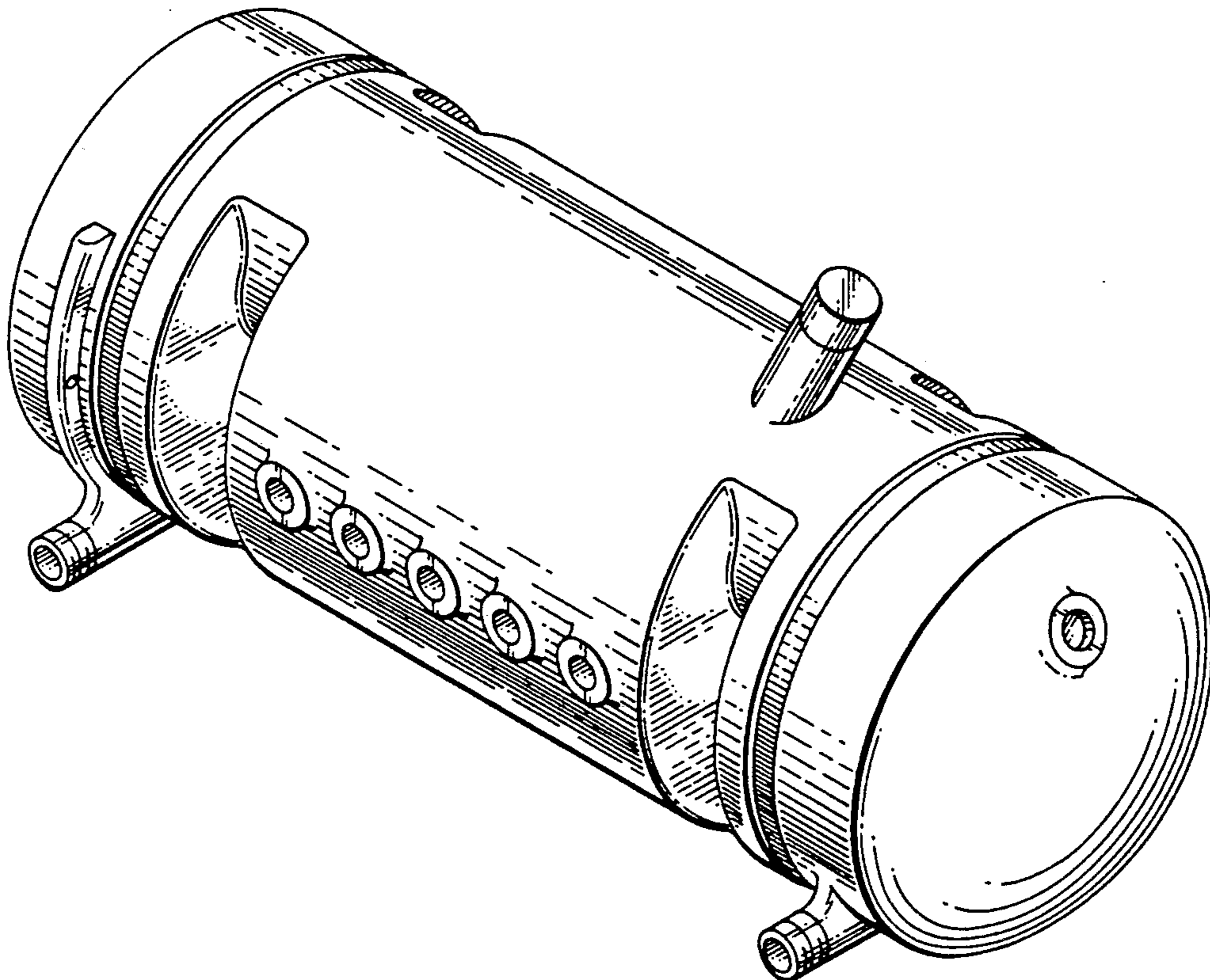

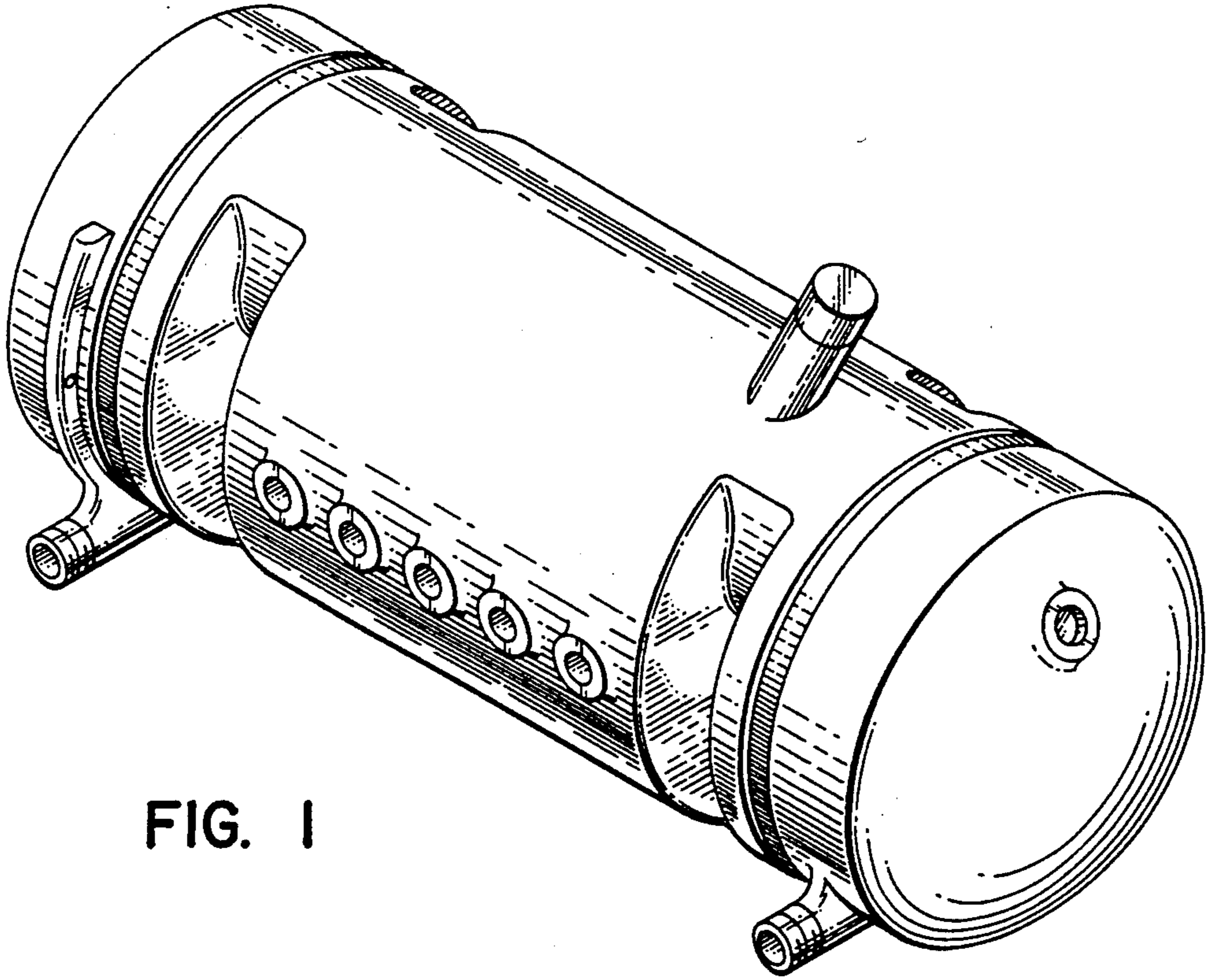

FIG. 1

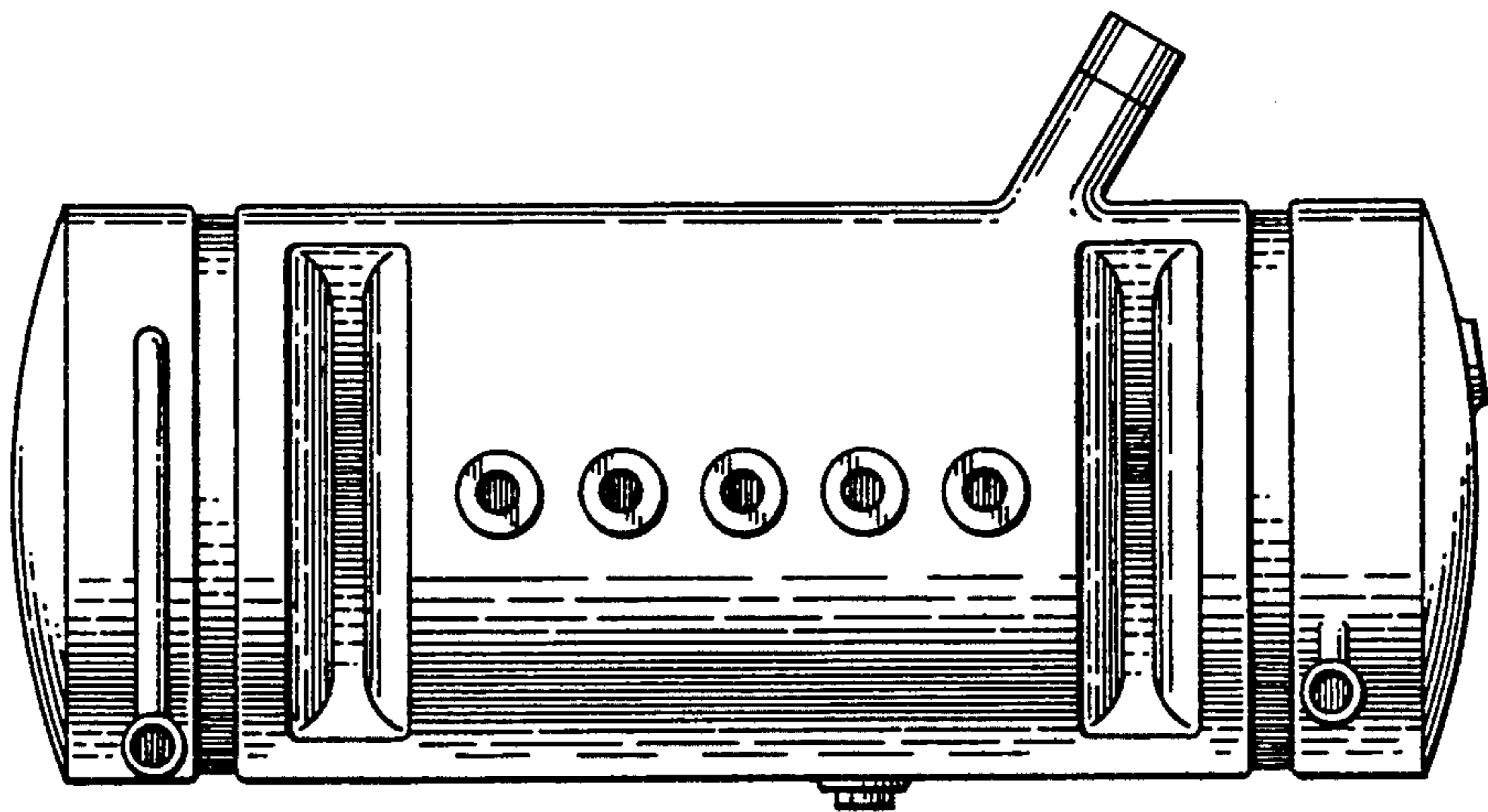

FIG. 2

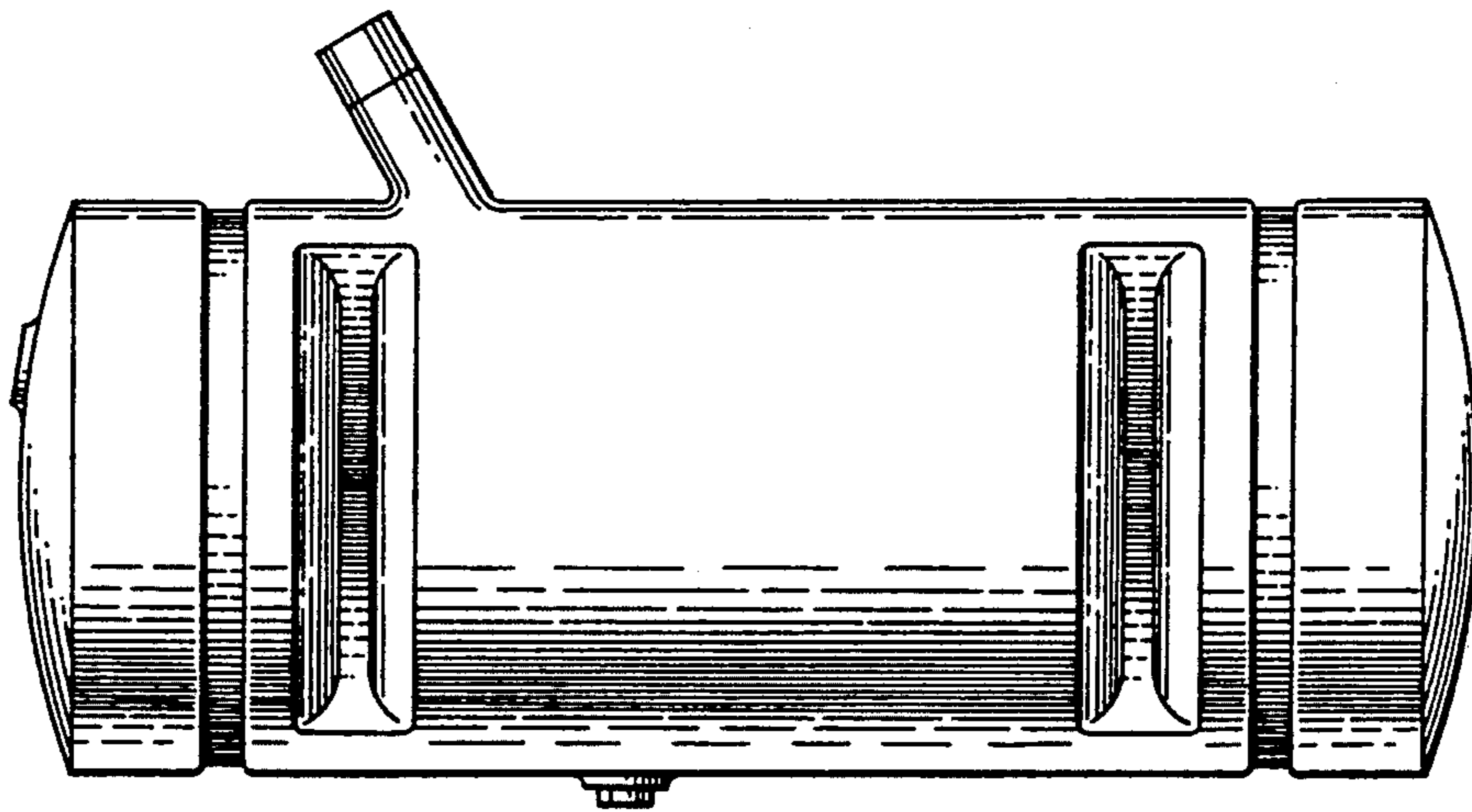

FIG. 3

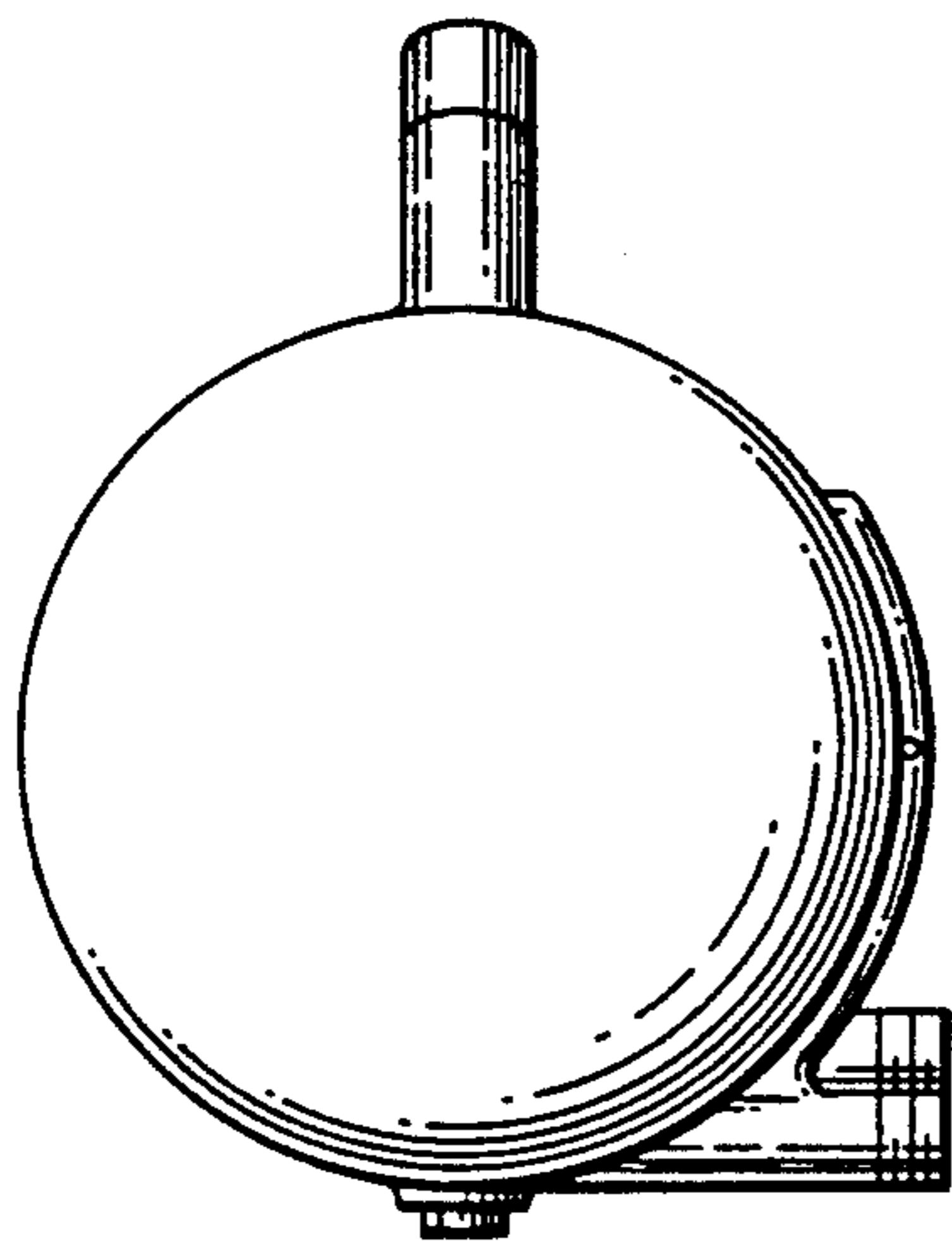

FIG. 4

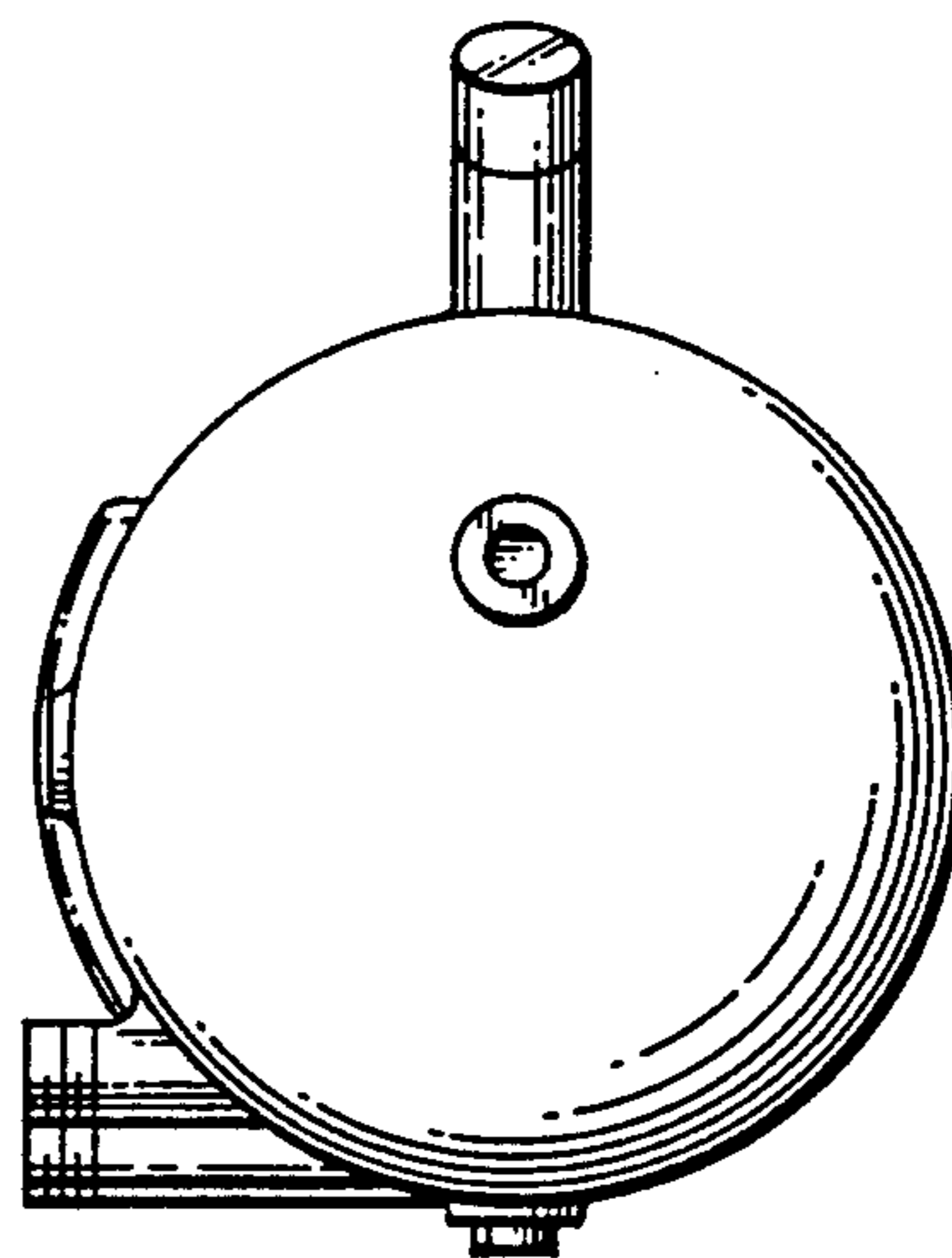

FIG. 5

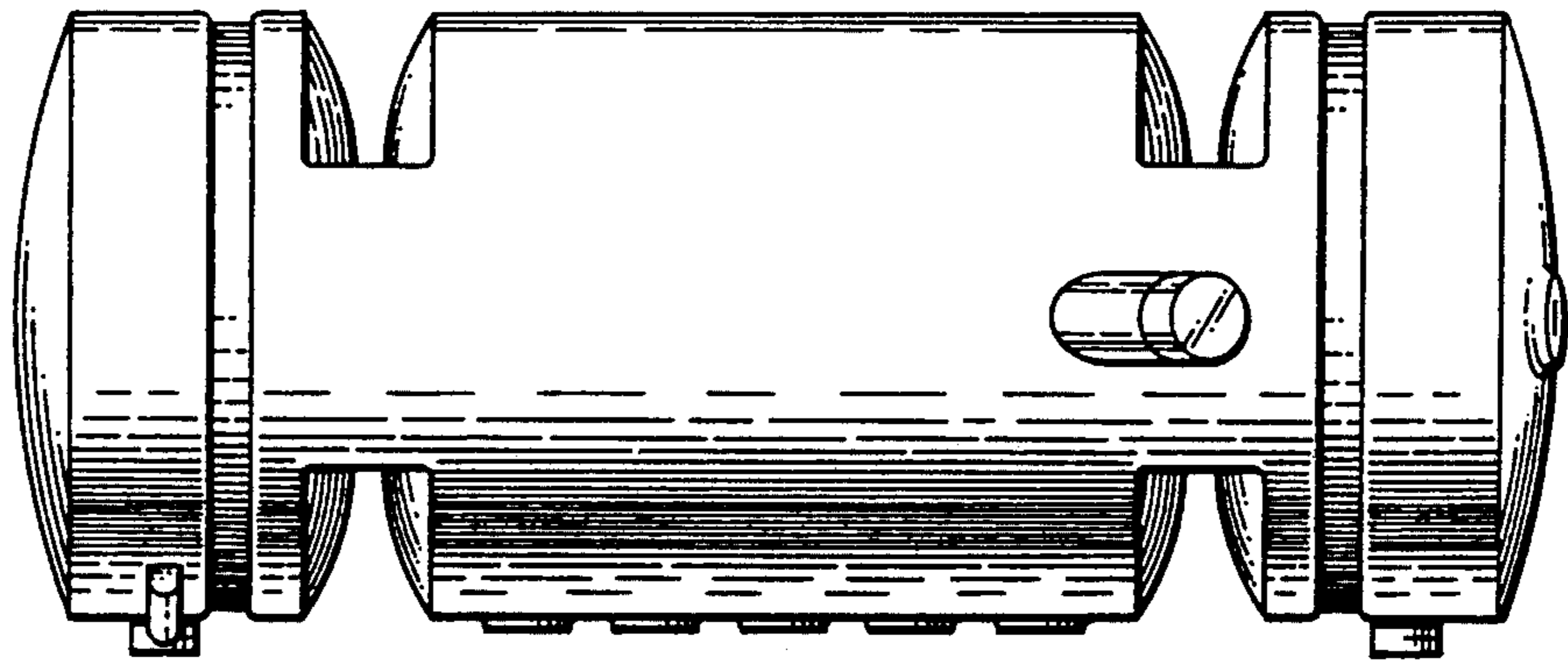

FIG. 6

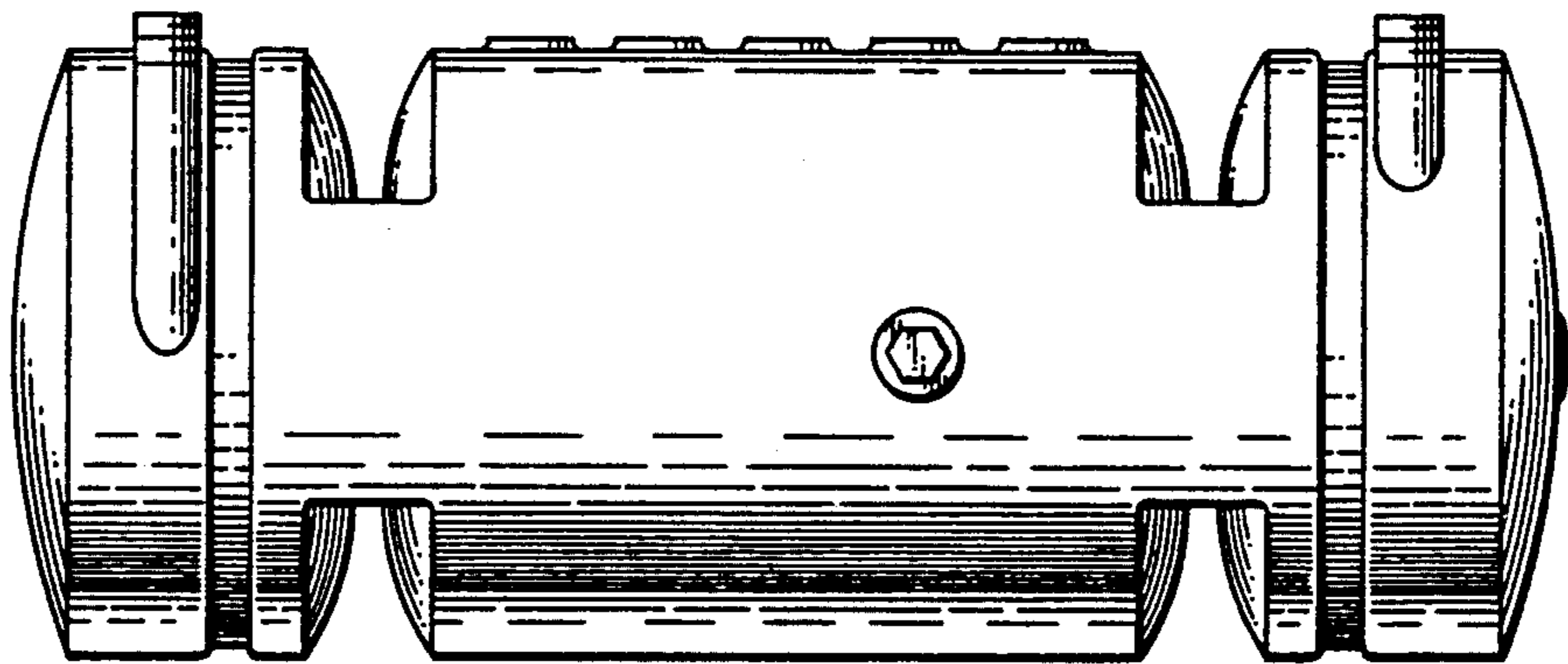

FIG. 7