

[54] BICYCLE HOLDER AND LOAD LATCH FOR USE ON A VEHICLE LUGGAGE RACK

[75] Inventor: Uno Johansson, Dalsjöfors, Sweden

[73] Assignee: JS Products AB, Dalsjöfors, Sweden

[**] Term: 14 Years

[21] Appl. No.: 162,581

[22] Filed: Mar. 1, 1988

[30] Foreign Application Priority Data

Sep. 2, 1987 [SE] Sweden 87-1936

[52] U.S. Cl. D12/157

[58] Field of Search D12/157; 224/329, 330, 224/351, 323, 315

[56] References Cited

U.S. PATENT DOCUMENTS

4,489,869 12/1984 Wienhold et al. 224/321

FOREIGN PATENT DOCUMENTS

2207231 5/1972 Fed. Rep. of Germany 224/314

2921703 12/1980 Fed. Rep. of Germany 224/331

0273480 7/1988 Fed. Rep. of Germany 224/330

Primary Examiner—James M. Gandy
Assistant Examiner—Melody Brown
Attorney, Agent, or Firm—Dvorak and Traub

[57] CLAIM

The ornamental design for a bicycle holder and load latch for use on a vehicle luggage rack, as shown and described.

DESCRIPTION

FIG. 1 is a top front and side perspective view of a bicycle holder and load latch for use on a vehicle luggage rack showing my new design with the latch in unlocked and raised condition;

FIG. 2 is a bottom rear and opposite side perspective view thereof;

FIG. 3 is a top front and side perspective view thereof with the latch in locked and lowered condition;

FIG. 4 is a bottom rear and opposite side perspective view of FIG. 3;

FIG. 5 is a perspective view thereof; and

FIG. 6 is a perspective view thereof in condition of use on a reduced scale.

The broken line showing of a portion of a vehicle luggage rack in FIGS. 5 and 6 is for illustrative purposes only and forms no part of the claimed design.

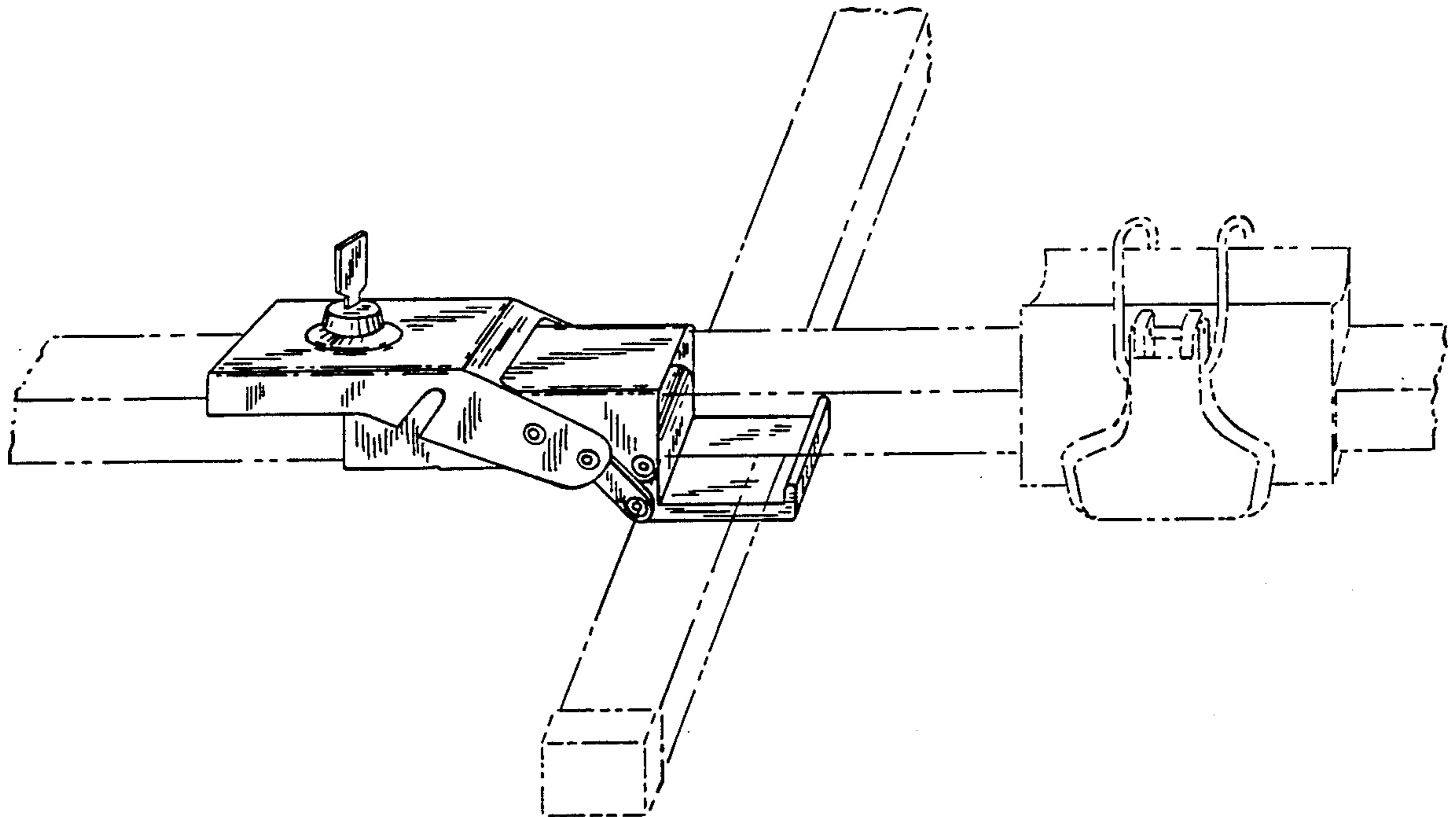

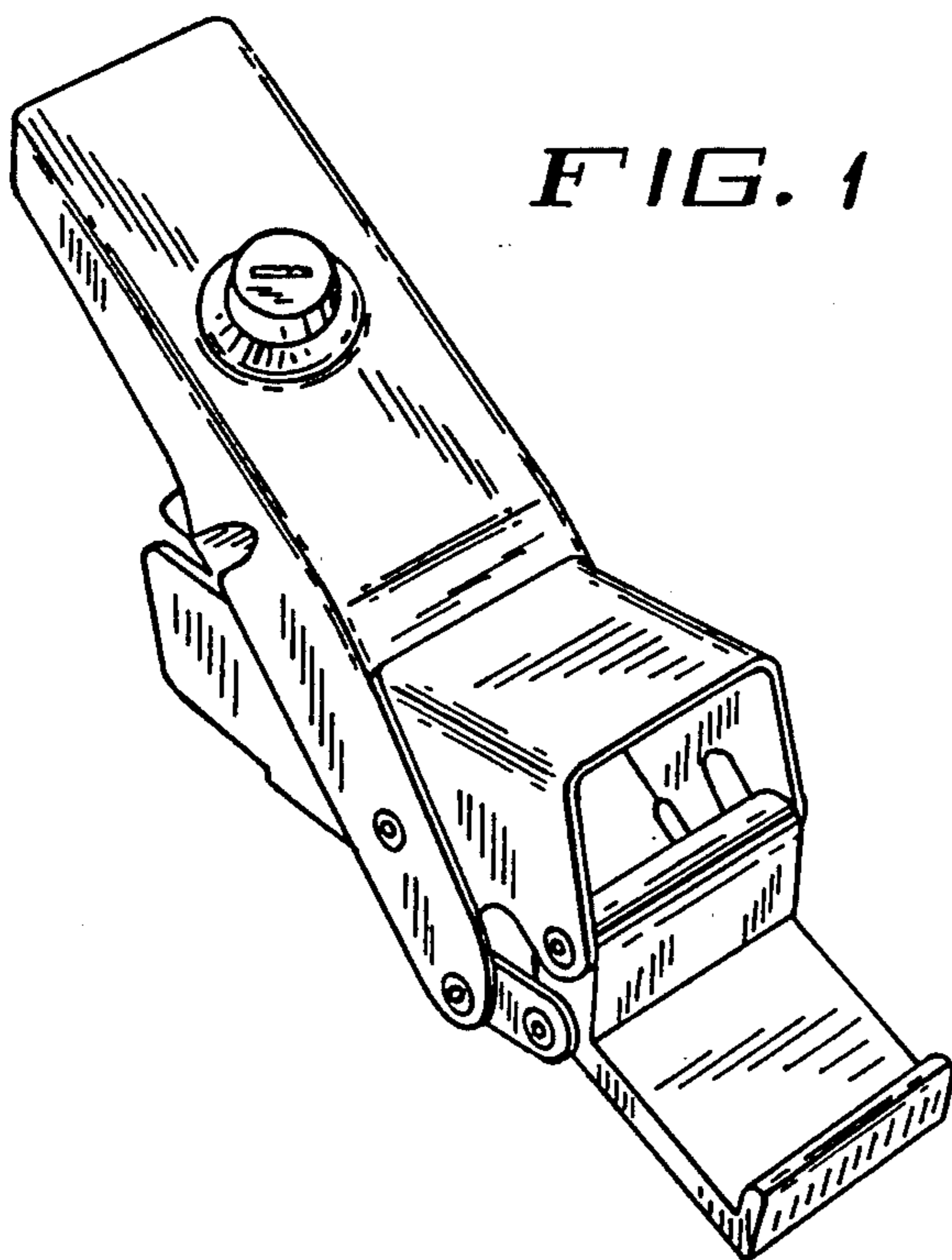

FIG. 1

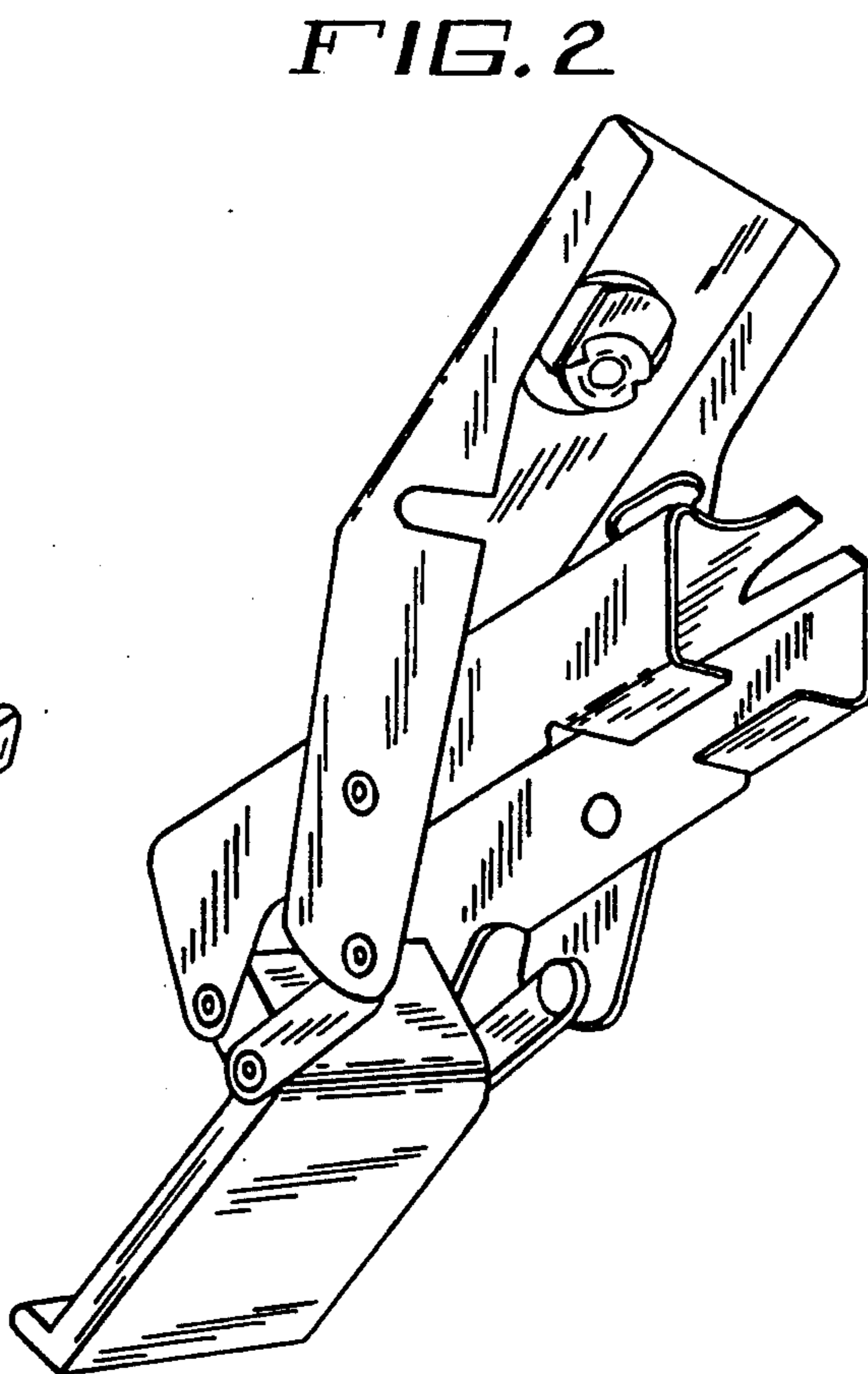

FIG. 2

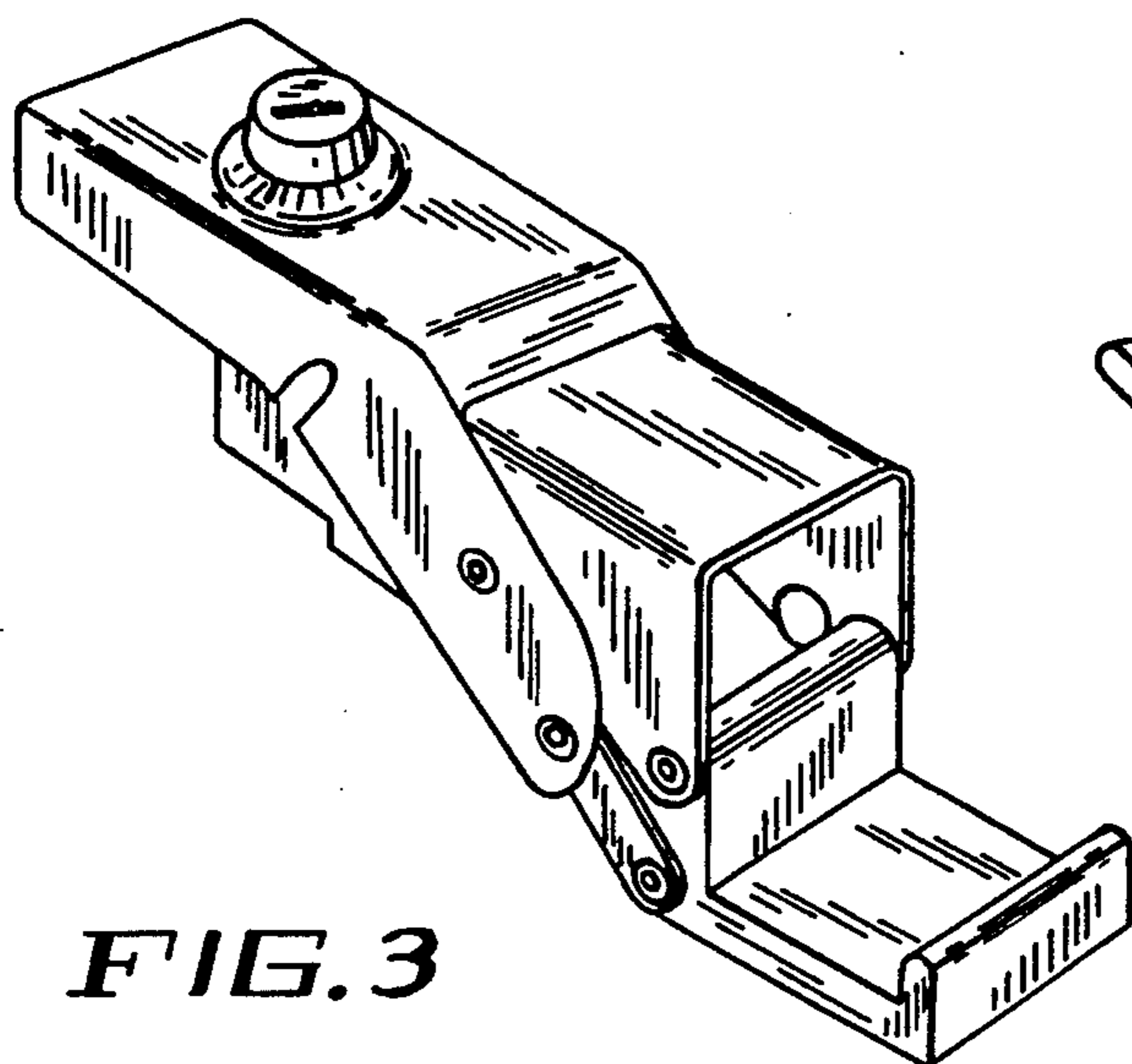

FIG. 3

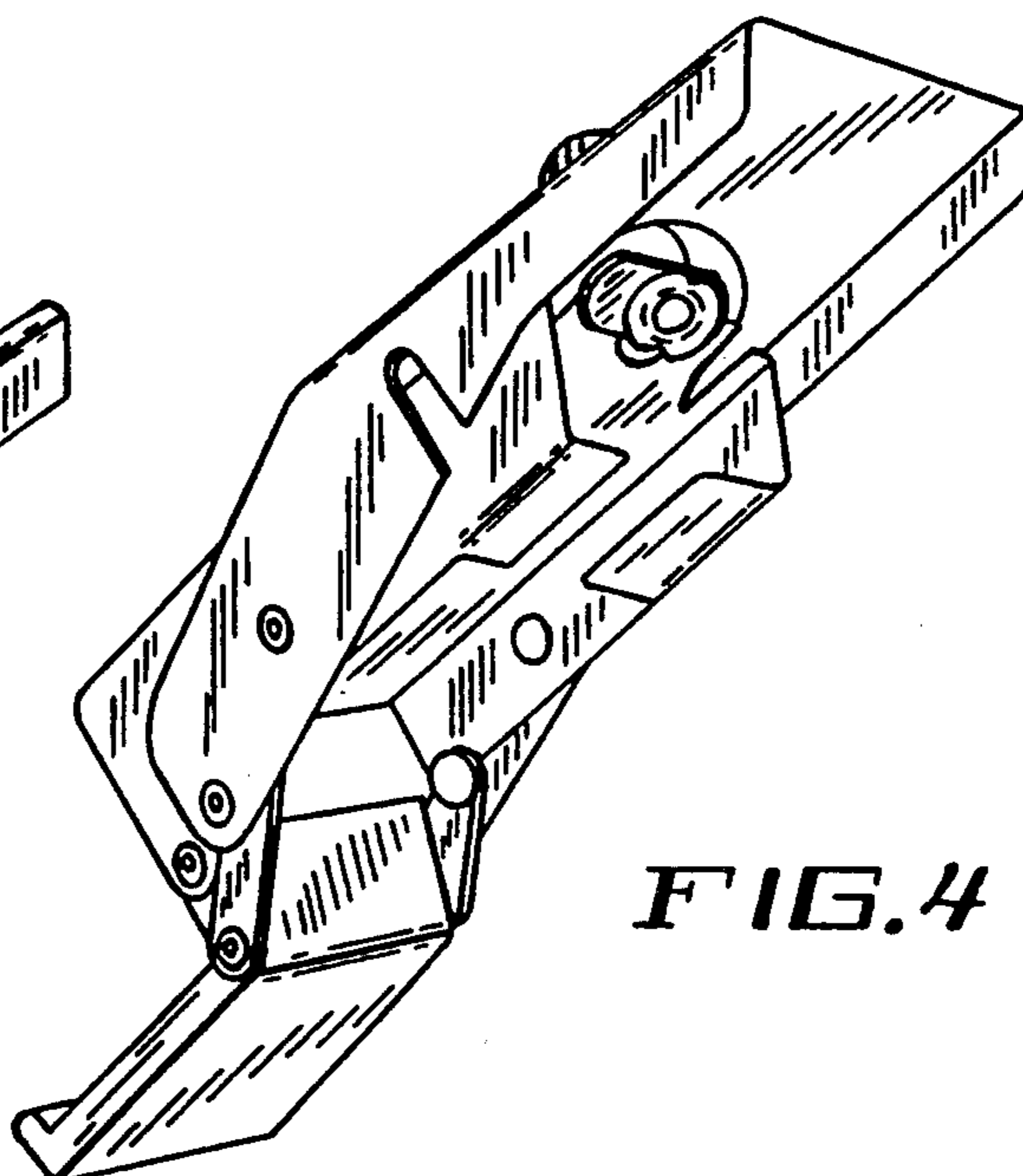

FIG. 4

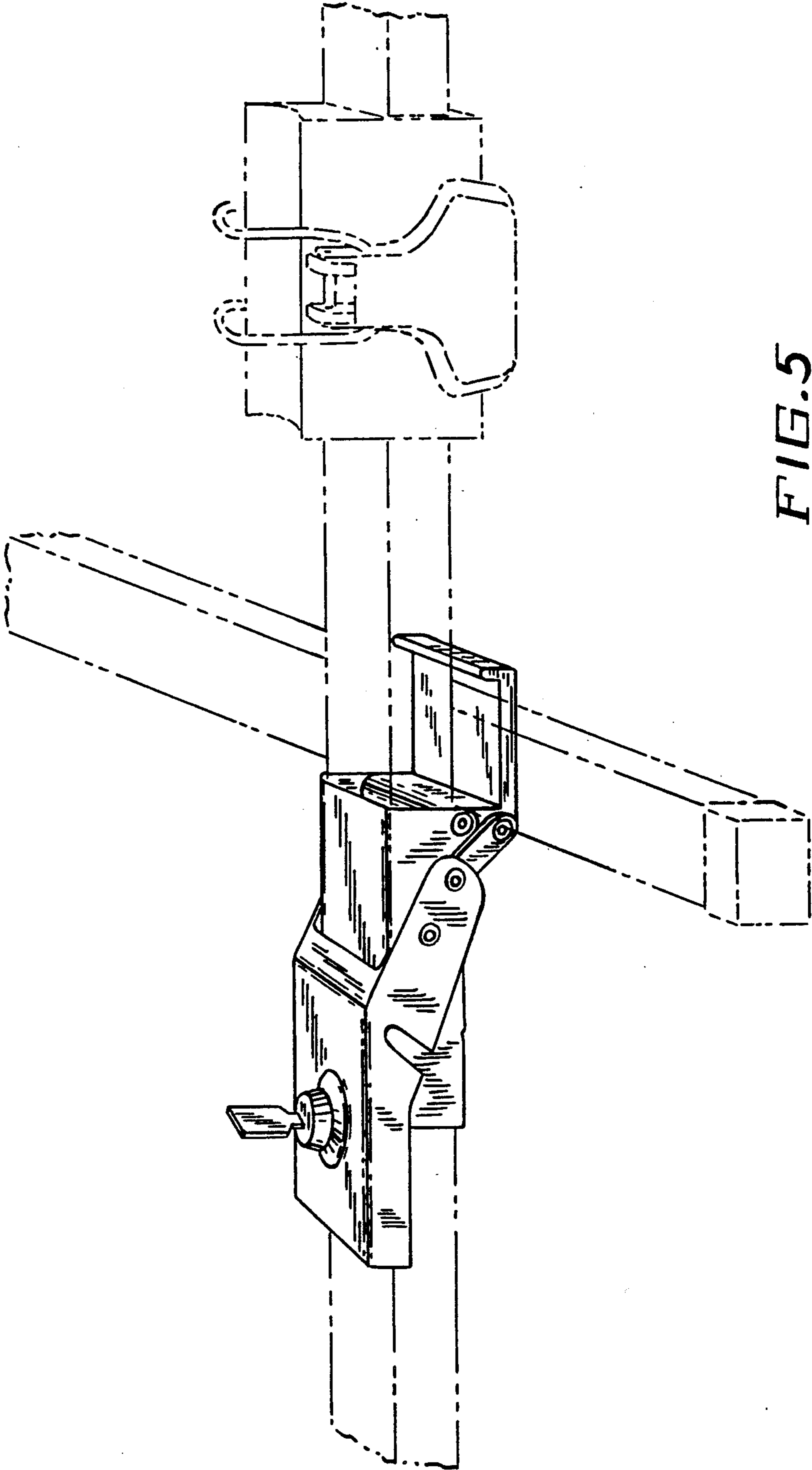

FIG. 5

FIG. 6

