

[54] SWING CHECK VALVE

[76] Inventor: John P. Scaramucci, 10724 Woodridden, Oklahoma City, Okla. 73170

[**] Term: 14 Years

[21] Appl. No.: 59,398

[22] Filed: Jun. 8, 1987

4,427,025 1/1984 Prince 137/527.4
4,586,534 5/1986 McNeely 137/527.4 X
4,605,041 8/1986 Teumer 137/527

Primary Examiner—James R. Largen
Assistant Examiner—Demetrius Reynolds
Attorney, Agent, or Firm—Dunlap, Coddington, Peterson & Lee

Related U.S. Application Data

[63] Continuation-in-part of Ser. No. 23,786, Mar. 9, 1987, abandoned.

[52] U.S. Cl. D23/237

[58] Field of Search 137/515.7, 527.5-527.8; 251/303; D23/233-247

References Cited

U.S. PATENT DOCUMENTS

- D. 202,701 11/1965 Davis D23/237
- D. 232,635 9/1974 Milan D23/237 X
- D. 278,079 3/1985 Widerby D23/237
- 1,399,684 12/1921 Belcher 137/527
- 2,532,067 11/1950 Bour 137/527.8
- 3,191,619 6/1965 Allen 137/527.4
- 3,565,107 2/1971 Bunch 137/527.8 X
- 3,626,148 12/1971 Woytowich 137/527.8 X
- 3,720,228 3/1973 Wheatley 137/515.7 X
- 3,817,277 6/1974 Wheatley 137/527.8 X
- 3,933,173 1/1976 Kajita 137/527.8
- 3,934,608 1/1976 Guyton 137/527.8
- 3,990,471 11/1976 Schutzer et al. 137/527
- 4,128,111 12/1978 Hansen et al. 137/515.7
- 4,201,241 5/1980 Schertler 137/527
- 4,223,697 9/1980 Pendleton 137/527.8
- 4,230,150 10/1980 Scaramucci 137/527.8 X
- 4,274,366 6/1981 Smith 137/527.8 X

[57] CLAIM

The ornamental design for a swing check valve, as shown and described.

DESCRIPTION

FIG. 1 is a side perspective view of a swing check valve showing my new design;

FIG. 2 is a perspective view taken from the side opposite that shown in FIG. 1;

FIG. 3 is a perspective view taken from the side shown in FIG. 1 showing the valve in an open position;

FIG. 4 is a perspective view taken from the opposite side of FIG. 3;

FIG. 5 is an exploded perspective view taken from the side shown in FIG. 1;

FIG. 6 is an exploded perspective view taken from the side shown in FIG. 2;

FIG. 7 is a side perspective view of a second embodiment thereof;

FIG. 8 is a perspective view taken from the side opposite that shown in FIG. 7;

FIG. 9 is a perspective view taken from the side shown in FIG. 7 showing the valve in an open position;

FIG. 10 is a perspective view taken from the opposite side of FIG. 9;

FIG. 11 is an exploded perspective view taken from the side shown in FIG. 7; and

FIG. 12 is an exploded perspective view taken from the side shown in FIG. 8.

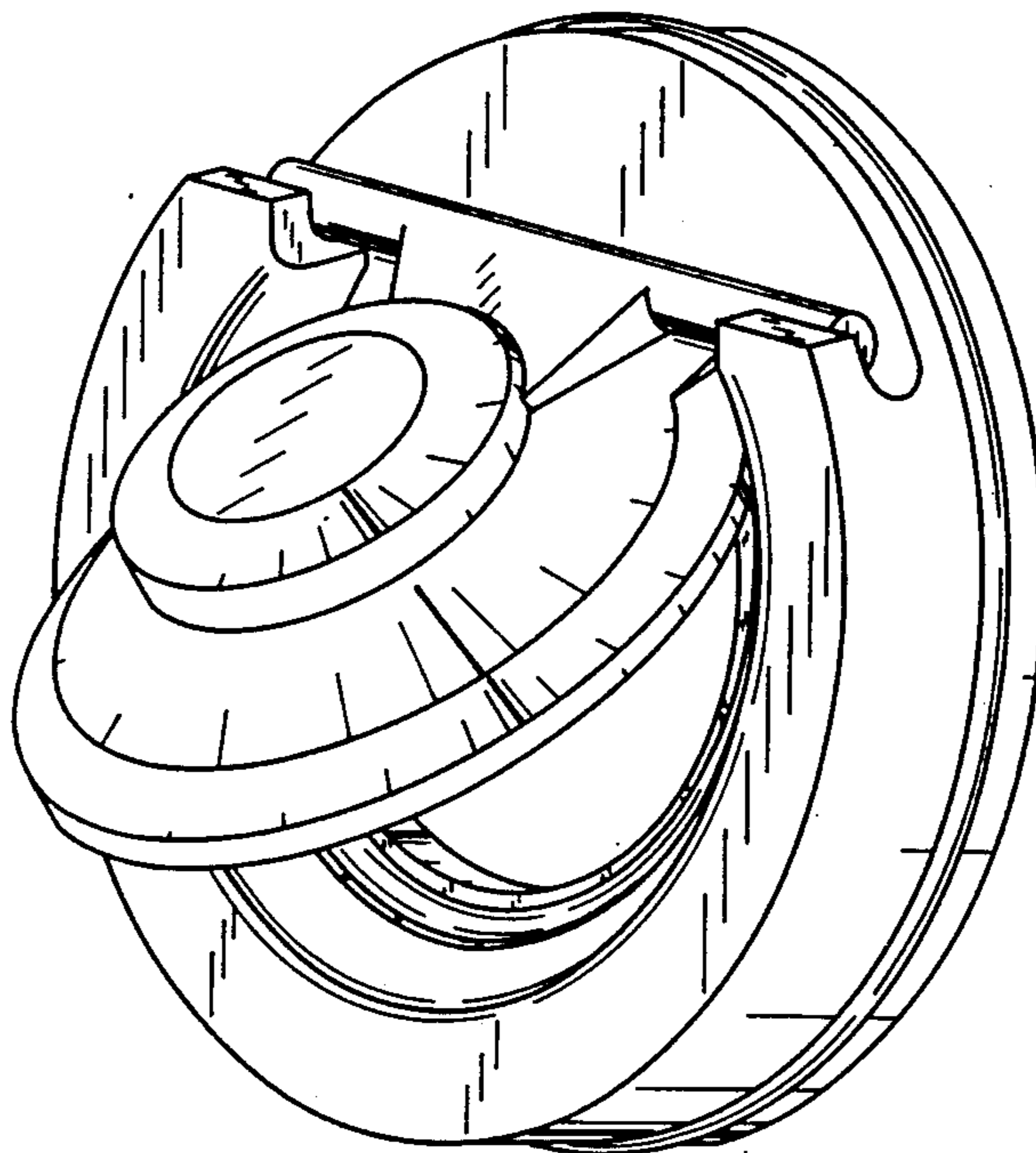

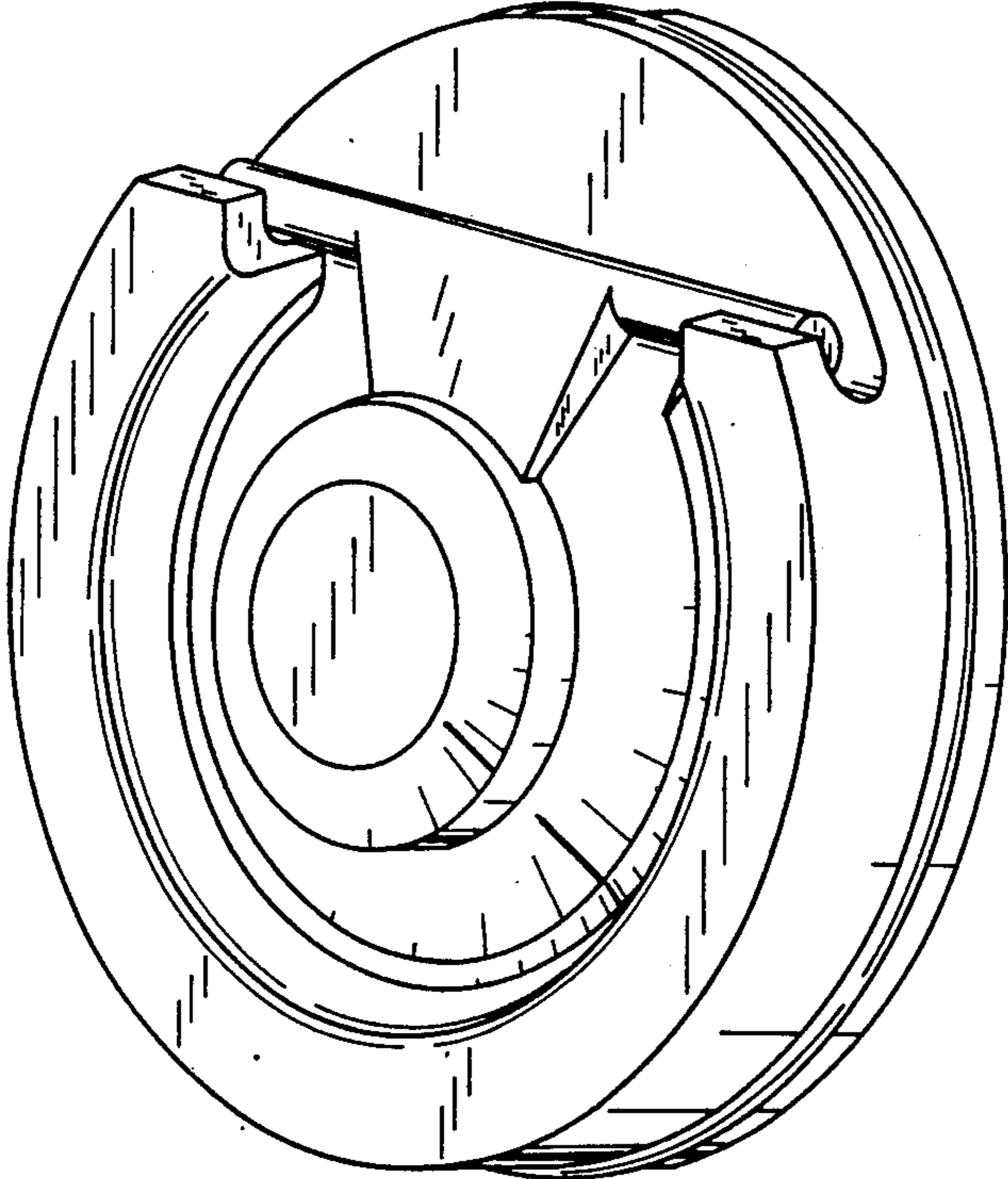

FIG. 1

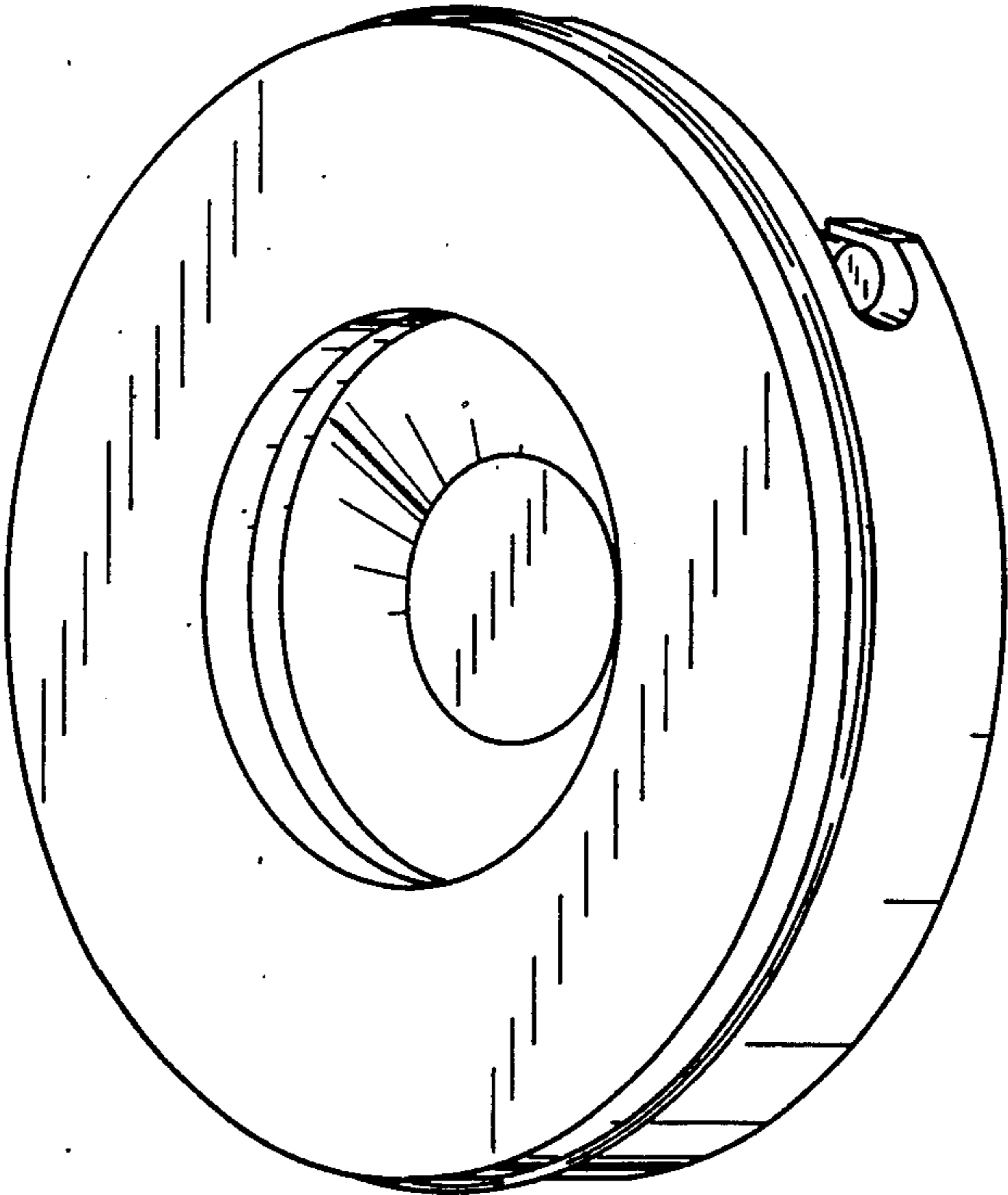

FIG. 2

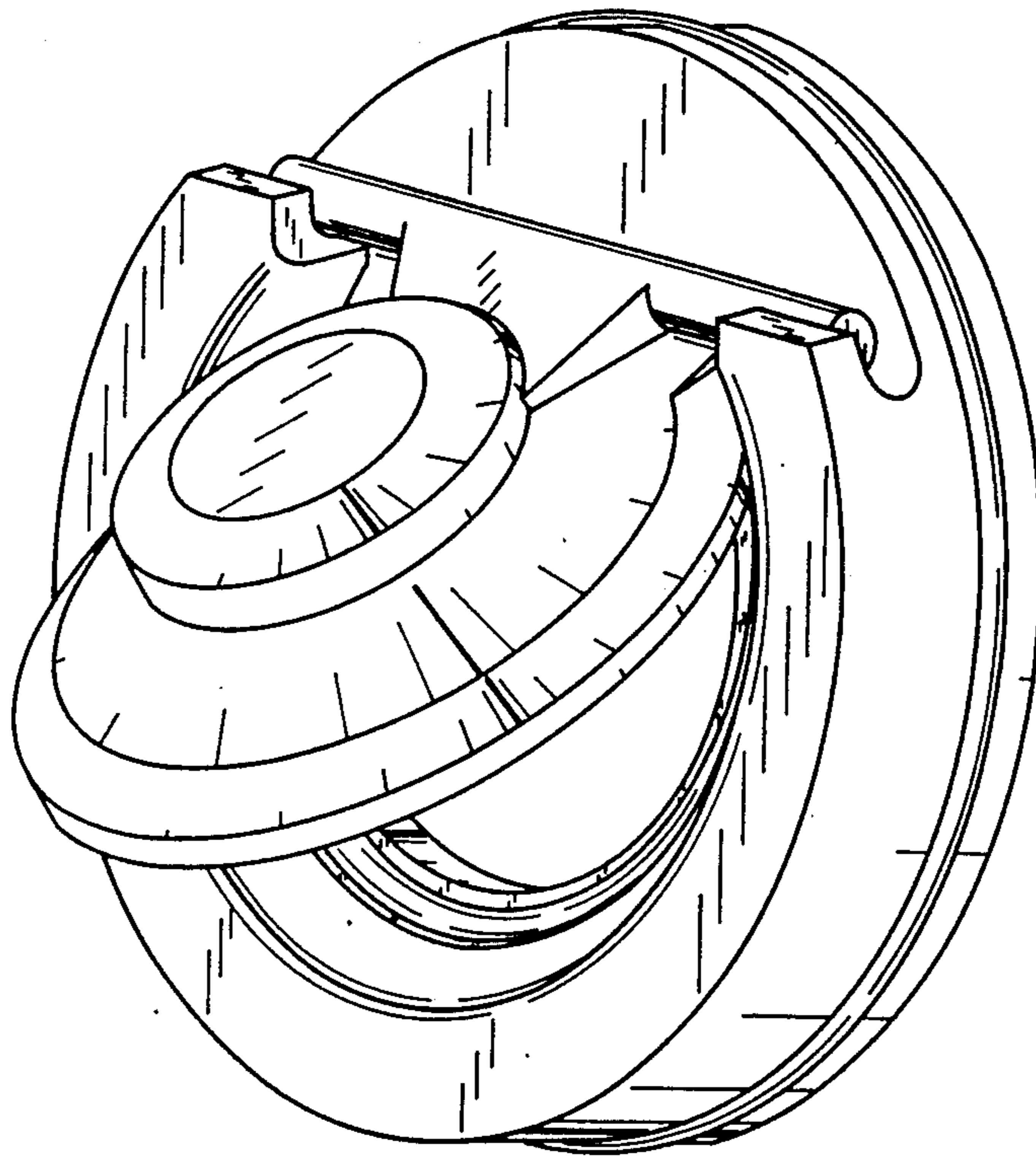

FIG. 3

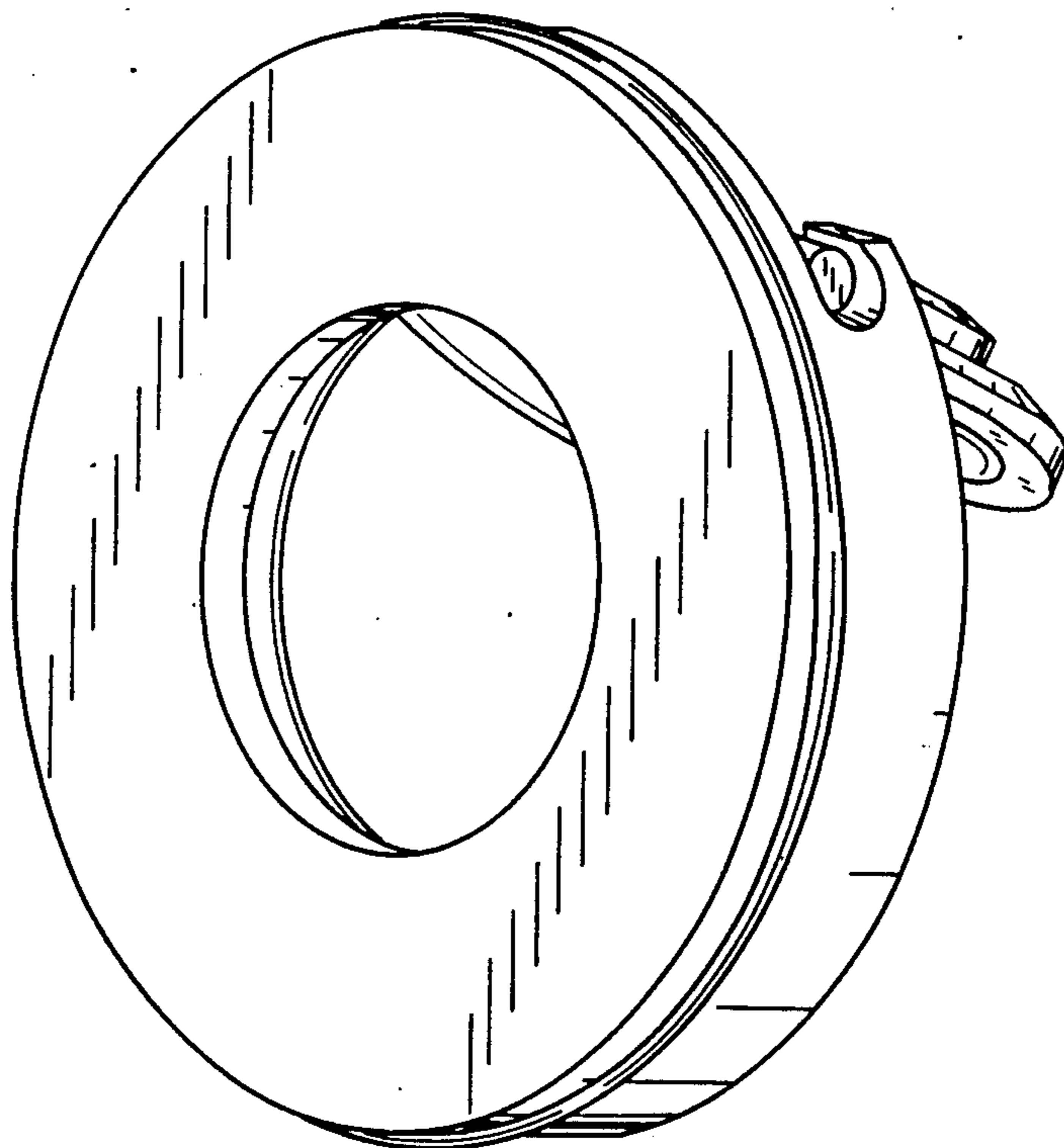

FIG. 4

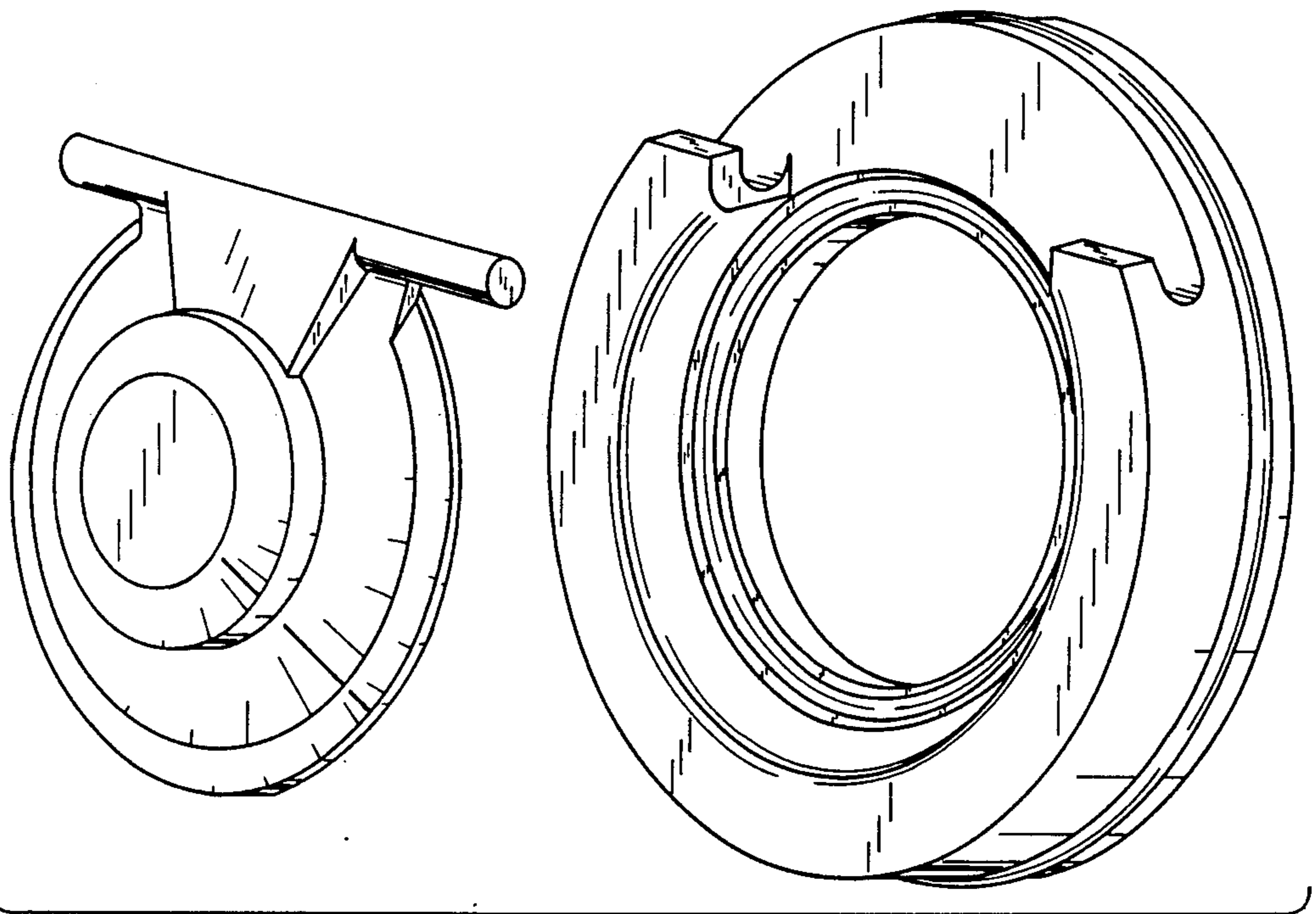

FIG. 5

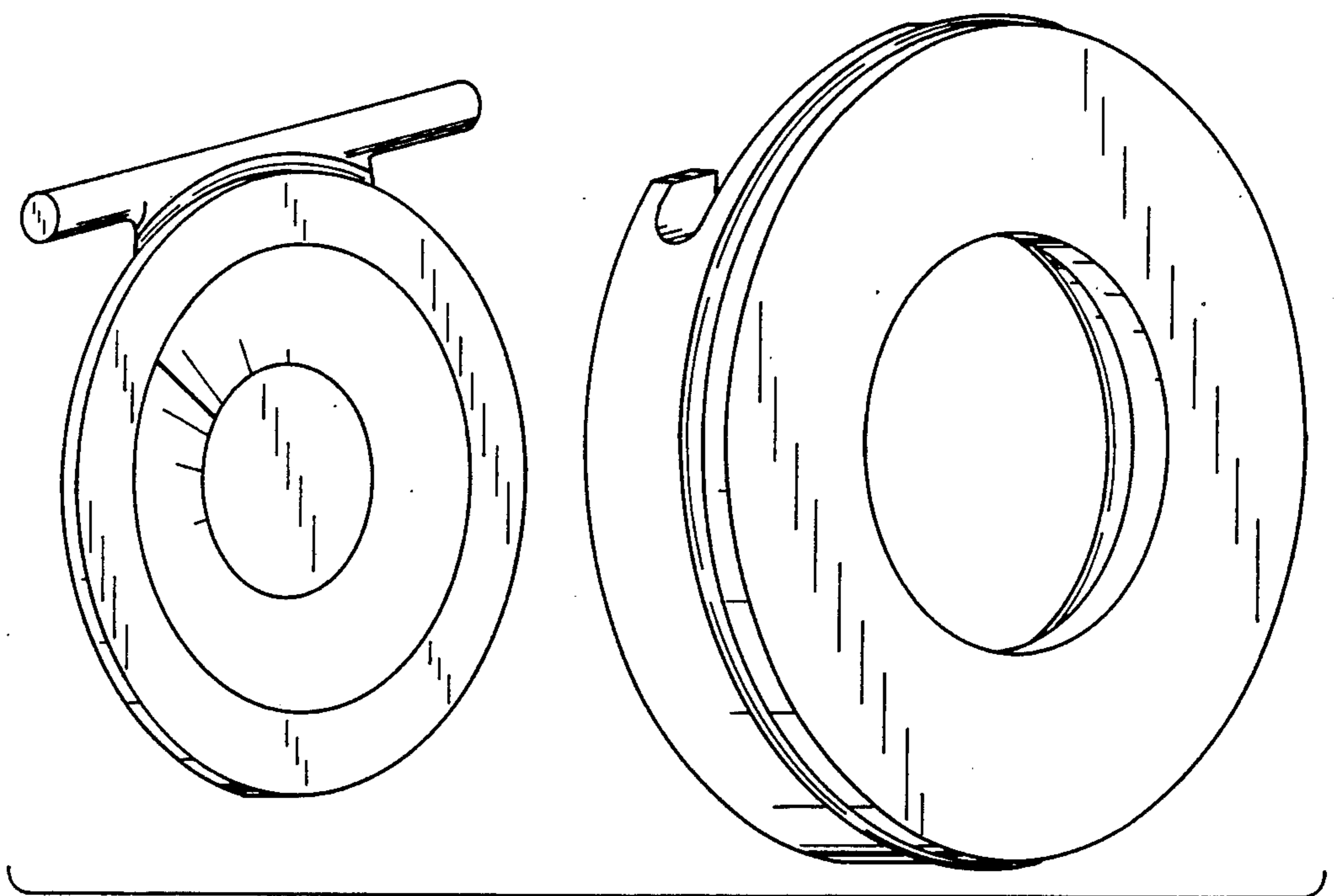

FIG. 6

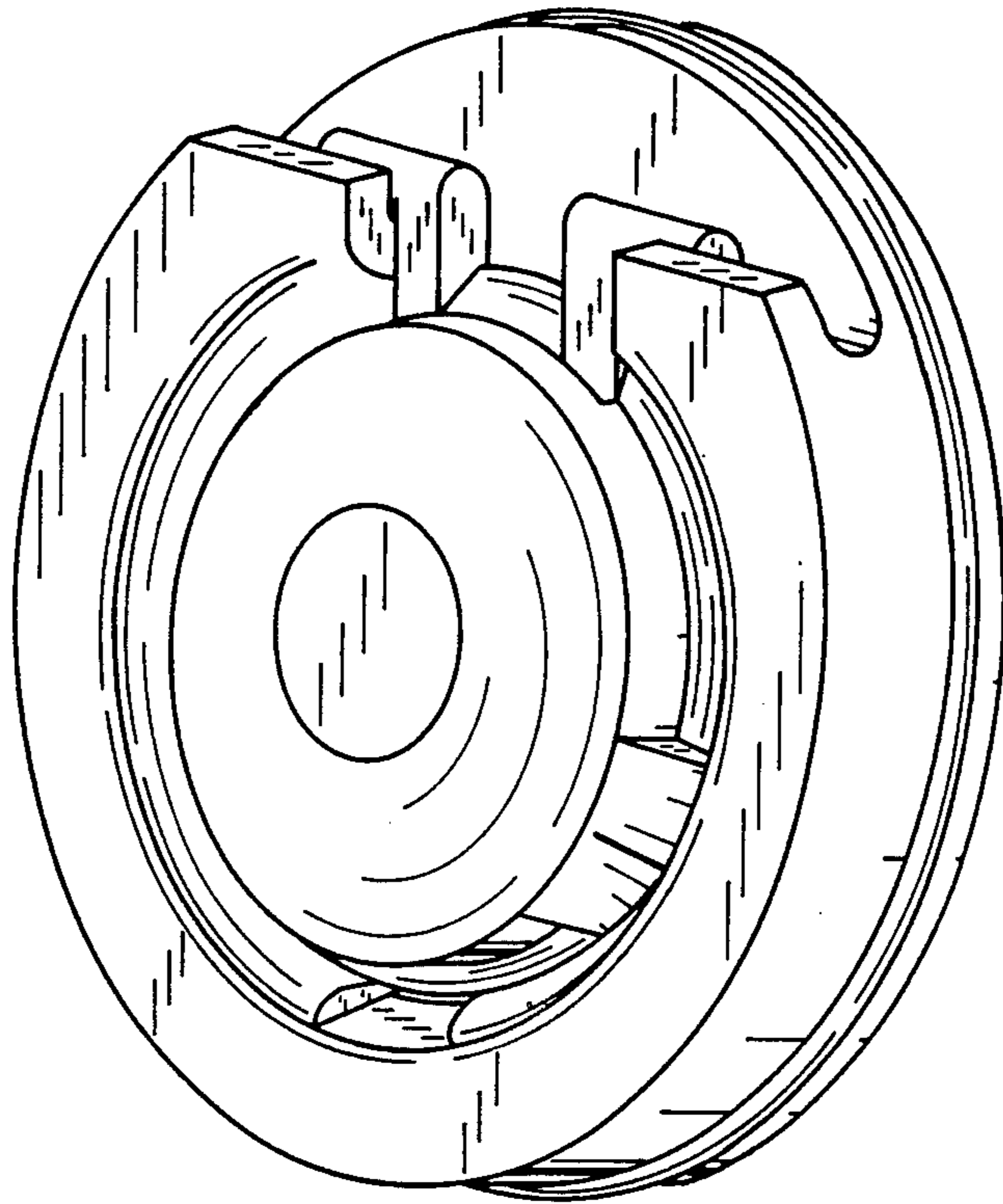

FIG. 7

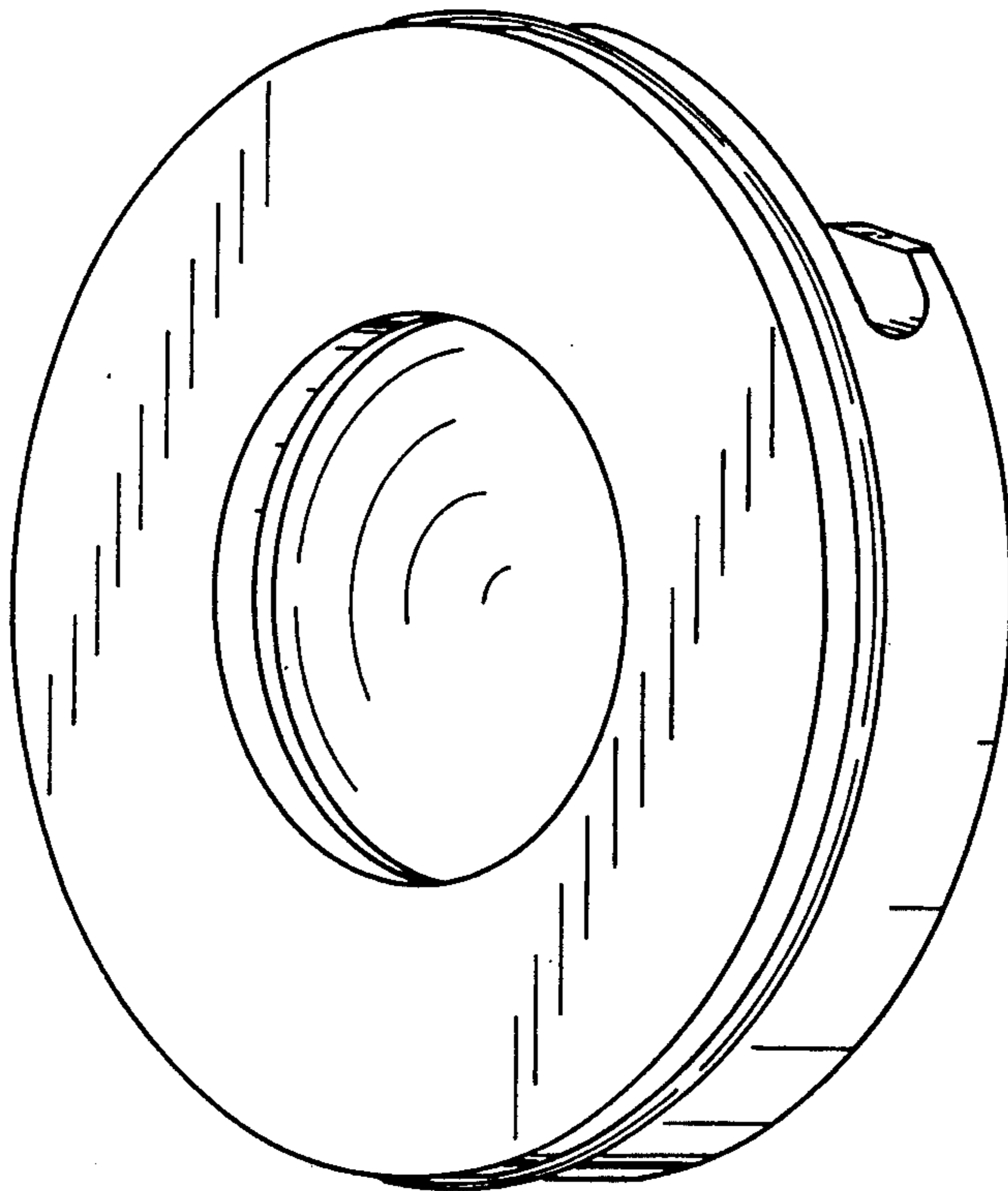

FIG. 8

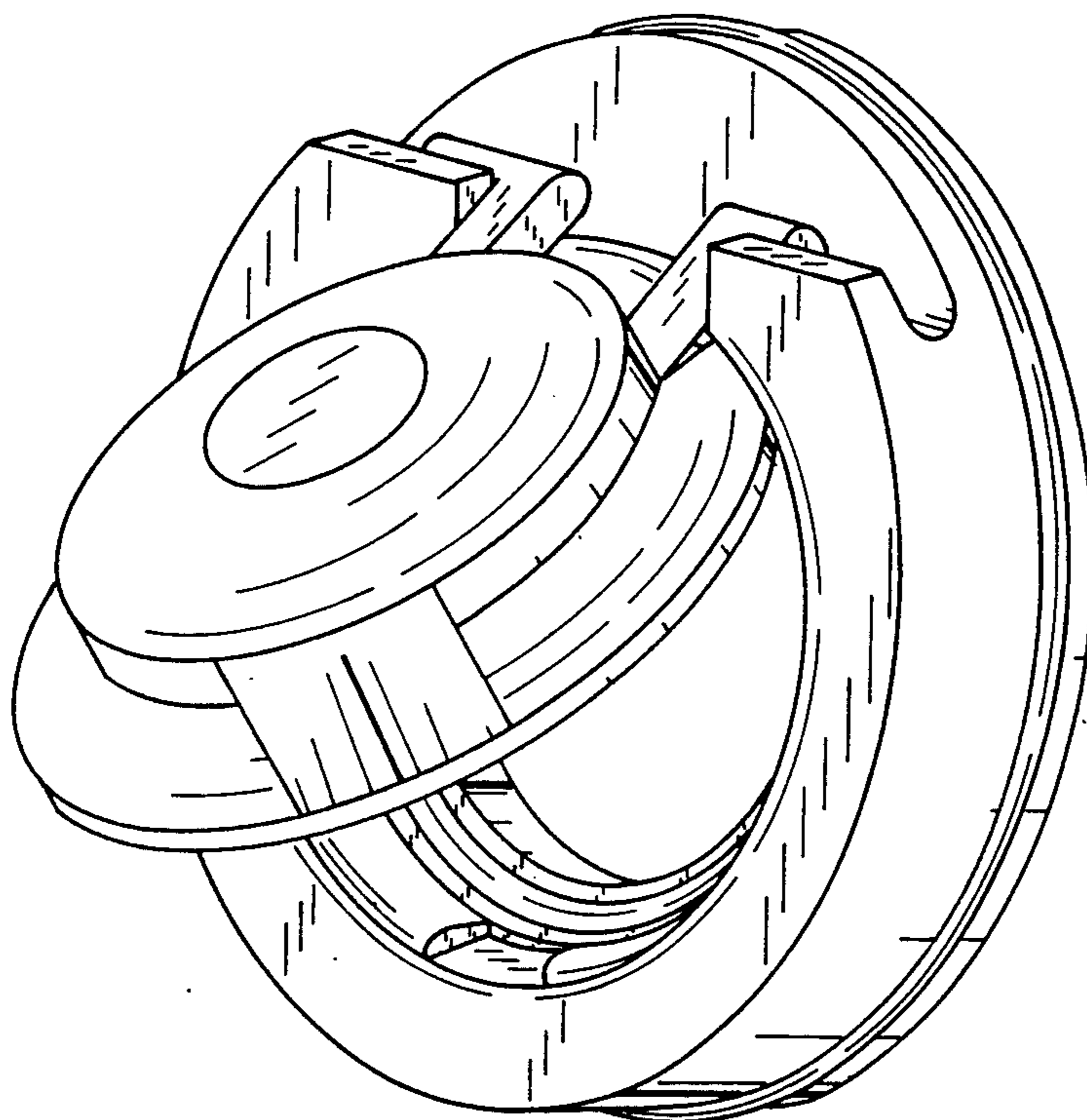

FIG. 9

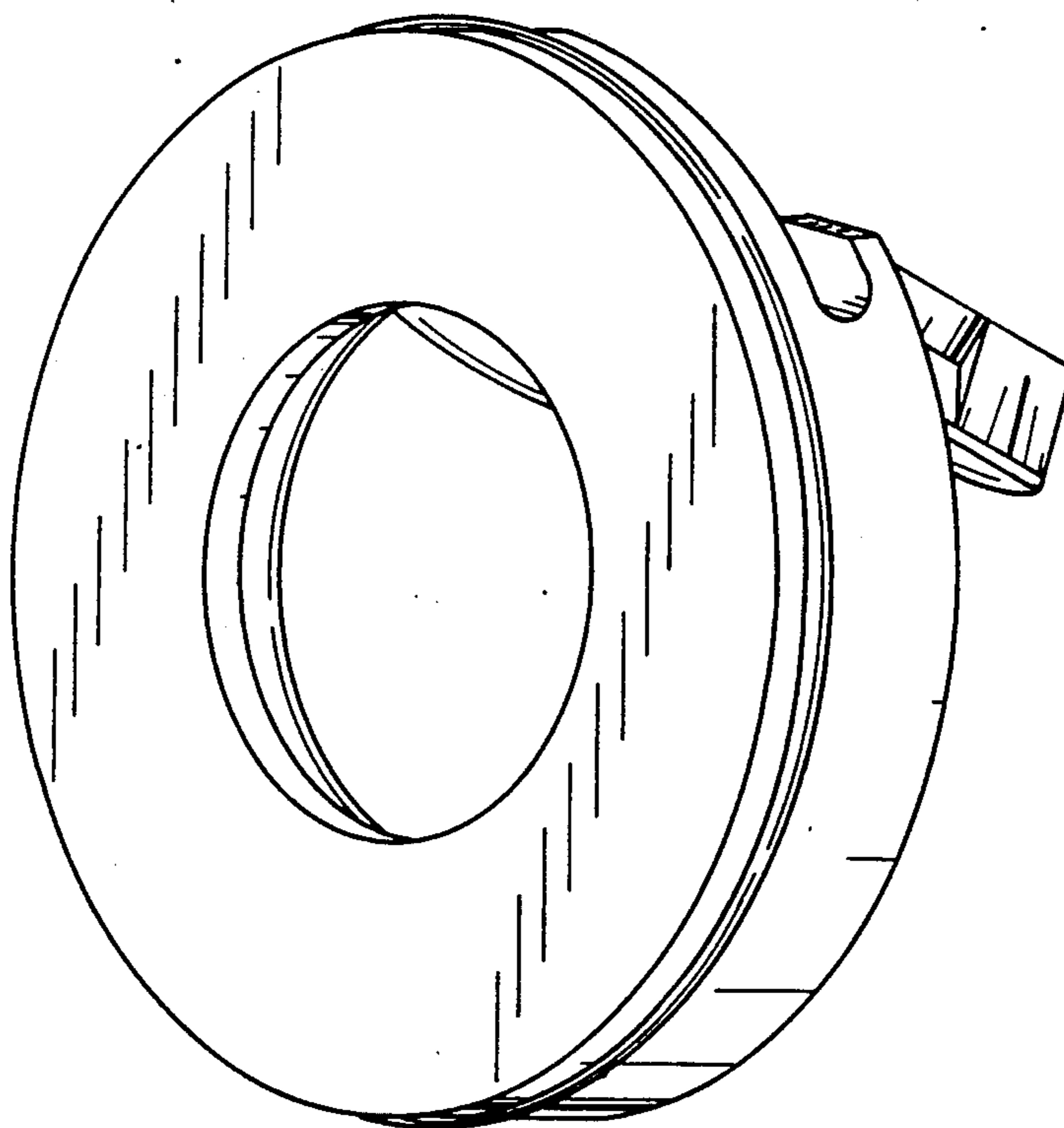

FIG. 10

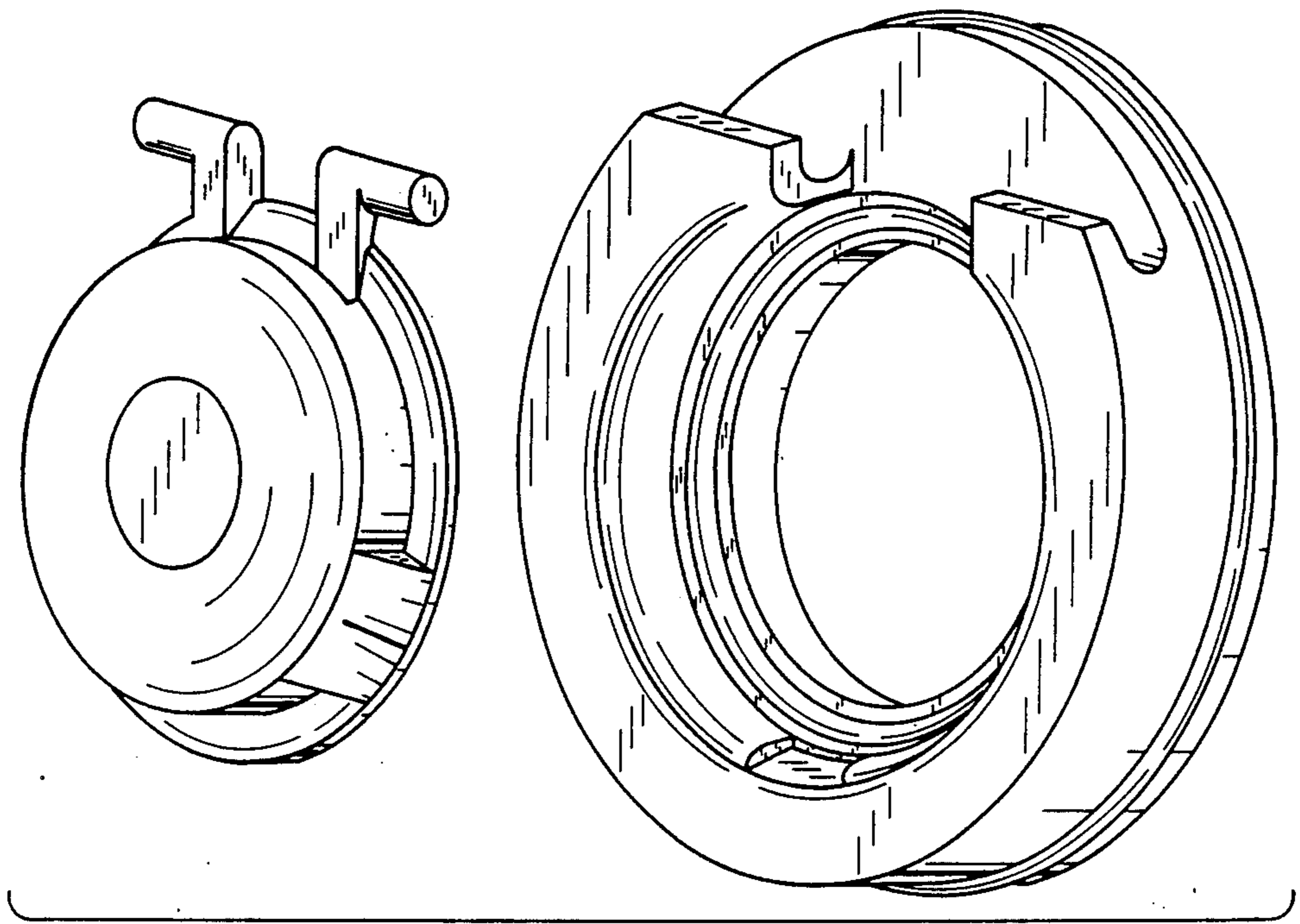

FIG. 11

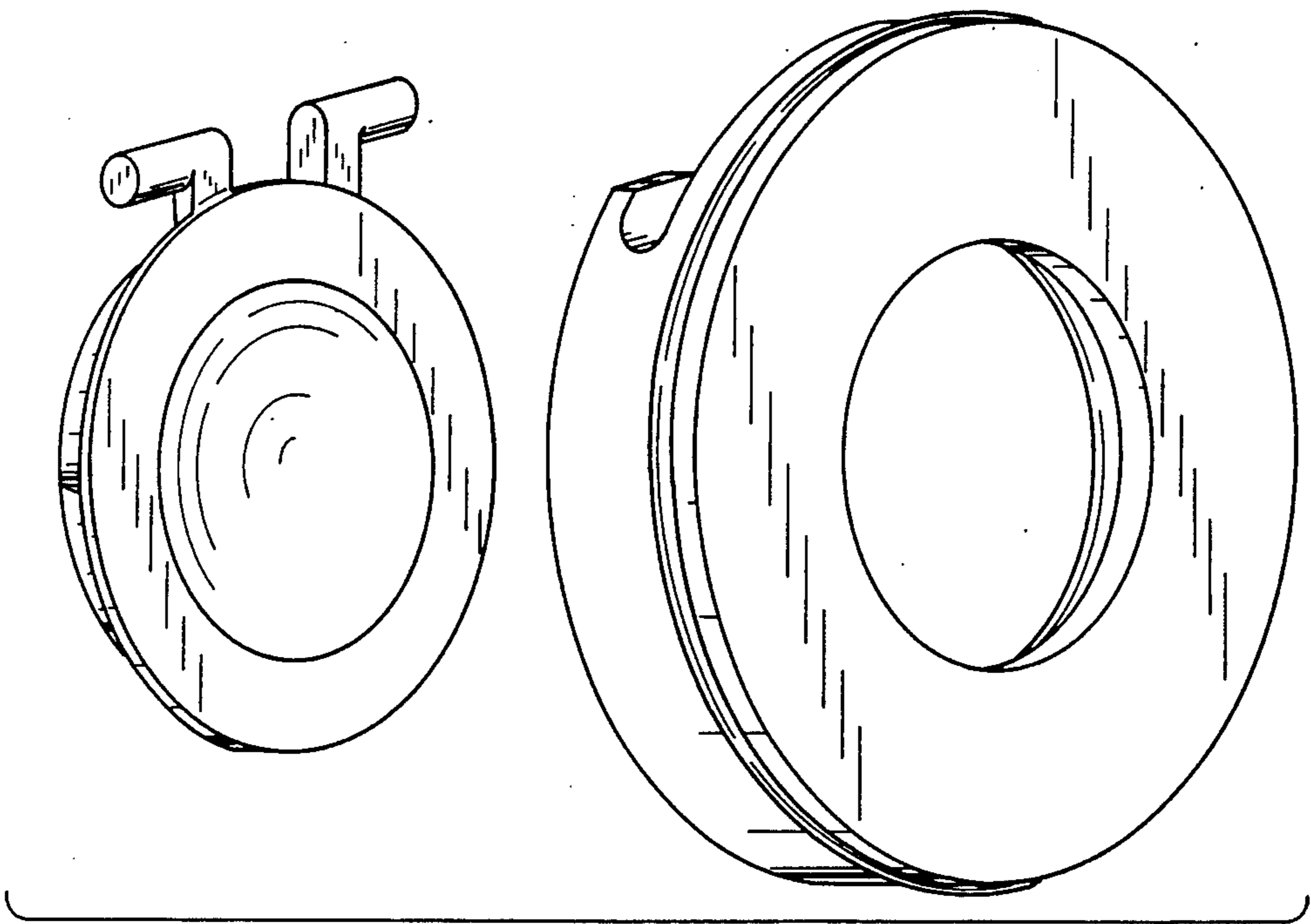

FIG. 12