

[54] BICYCLE FRAME

[76] Inventor: Sidney S. Brown, 2269 Creston Ave., Bronx, N.Y. 10453

[**] Term: 14 Years

[21] Appl. No.: 442,940

[22] Filed: Nov. 29, 1989

[52] U.S. Cl. D12/111

[58] Field of Search D12/111; 280/281.1, 280/288.1, 288.2, 288.3, 284; D21/194; 74/594.6

[56] References Cited

U.S. PATENT DOCUMENTS

D. 246,171	10/1977	Dodd	D12/111
D. 299,669	1/1989	Harter	D21/194
D. 300,047	2/1989	Sheltra	D21/194
D. 308,085	5/1990	Alberta	D21/194
4,732,404	3/1988	Coetzee	74/594.6
4,733,881	3/1988	Mueller	280/281.1

OTHER PUBLICATIONS

American Bicyclist & Motorcyclist, Mar. 1989, p. 64, Piranha Boys Chrome Bicycle.

American Bicyclist & Motorcyclist, Oct. 1986, p. 14, Willing, Model W-910 Freestyle Cycle.

Primary Examiner—James M. Gandy

Assistant Examiner—Melody N. Brown

Attorney, Agent, or Firm—Richard L. Miller

[57] CLAIM

The ornamental design for a bicycle frame, as shown.

DESCRIPTION

FIG. 1 is a top plan view of a bicycle frame showing my new design;

FIG. 2 is a front elevational view thereof;

FIG. 3 is a left side elevational view thereof;

FIG. 4 is a bottom plan view thereof;

FIG. 5 is a right side elevational view thereof; and

FIG. 6 is a rear elevational view thereof.

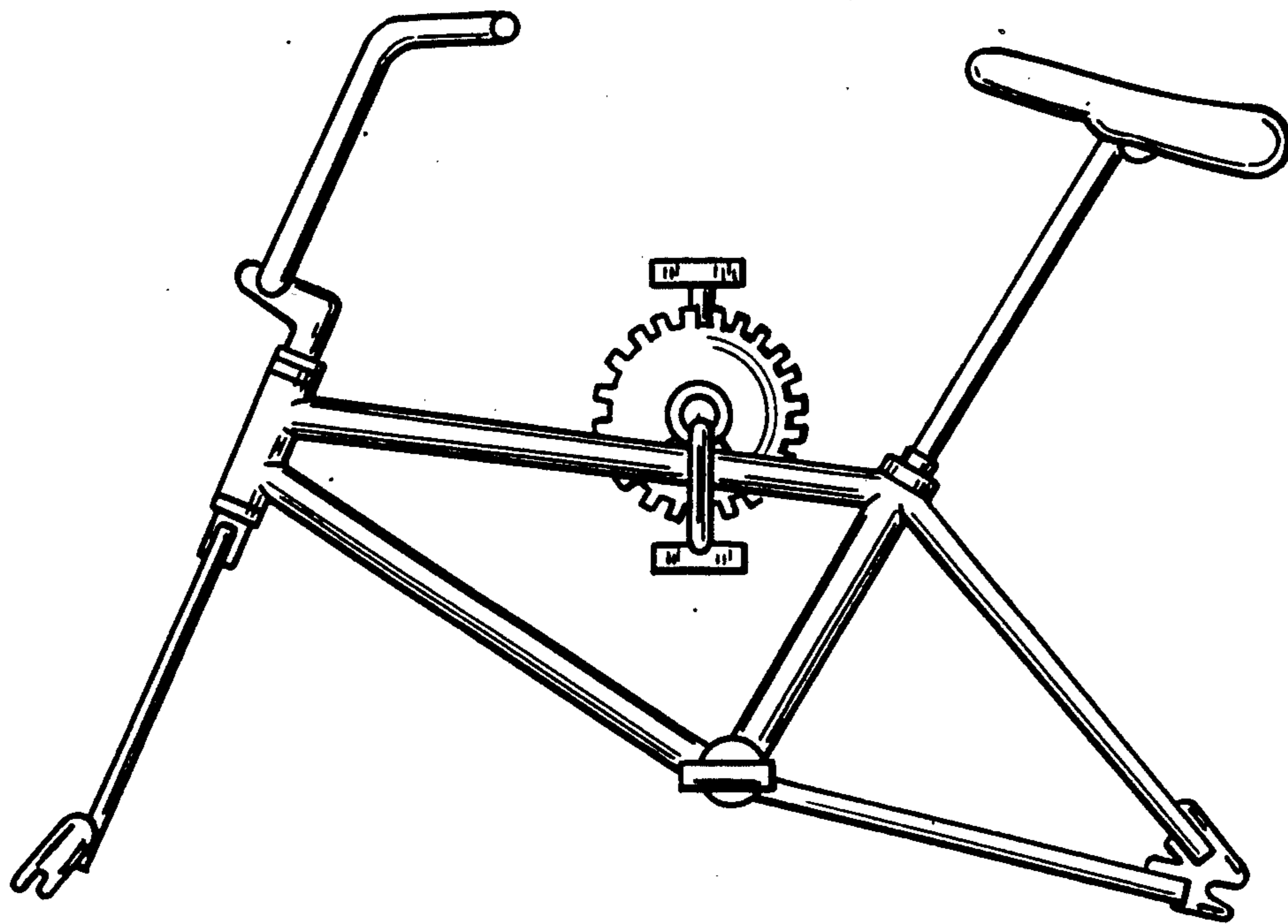

FIG. 1

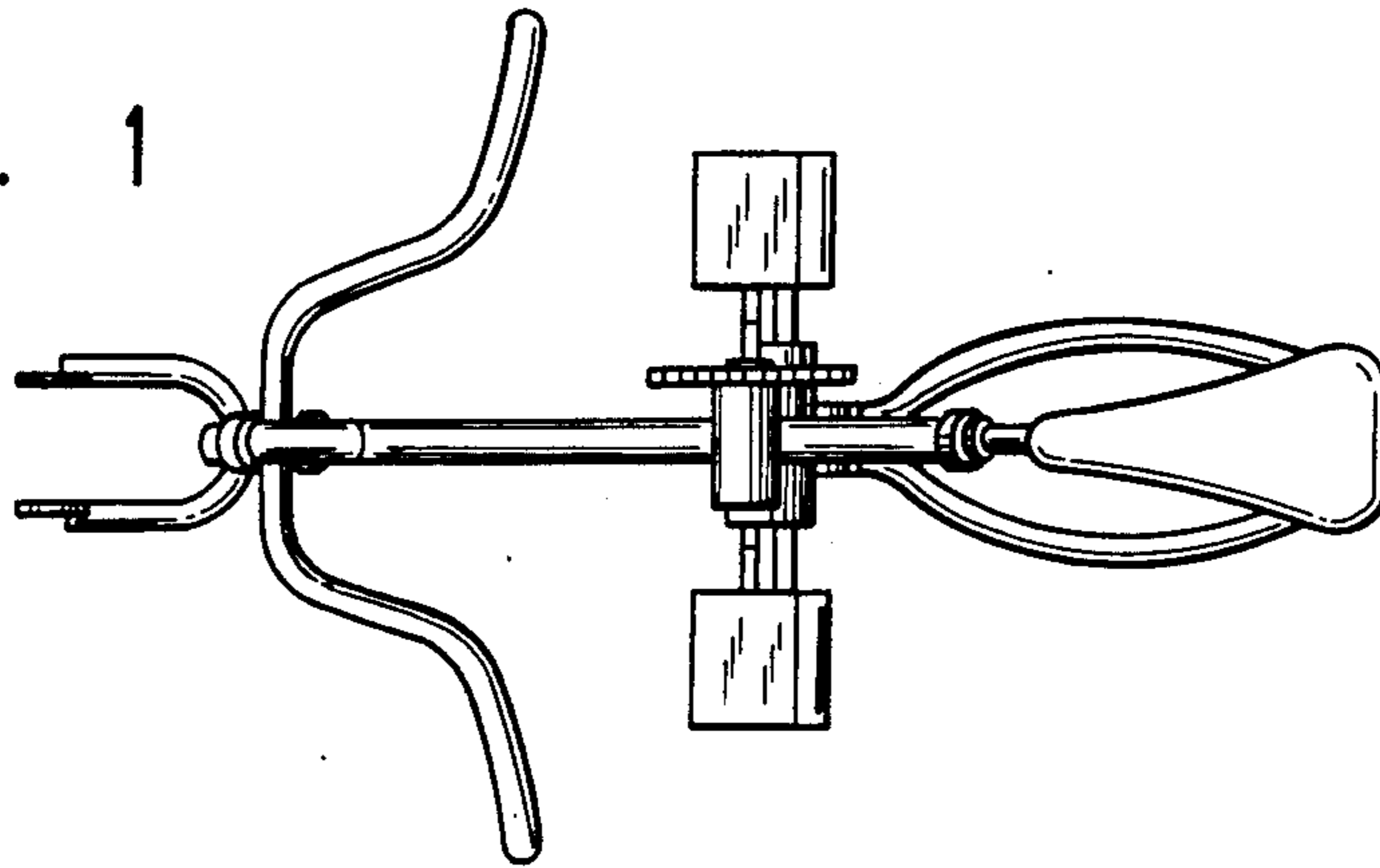

FIG. 2

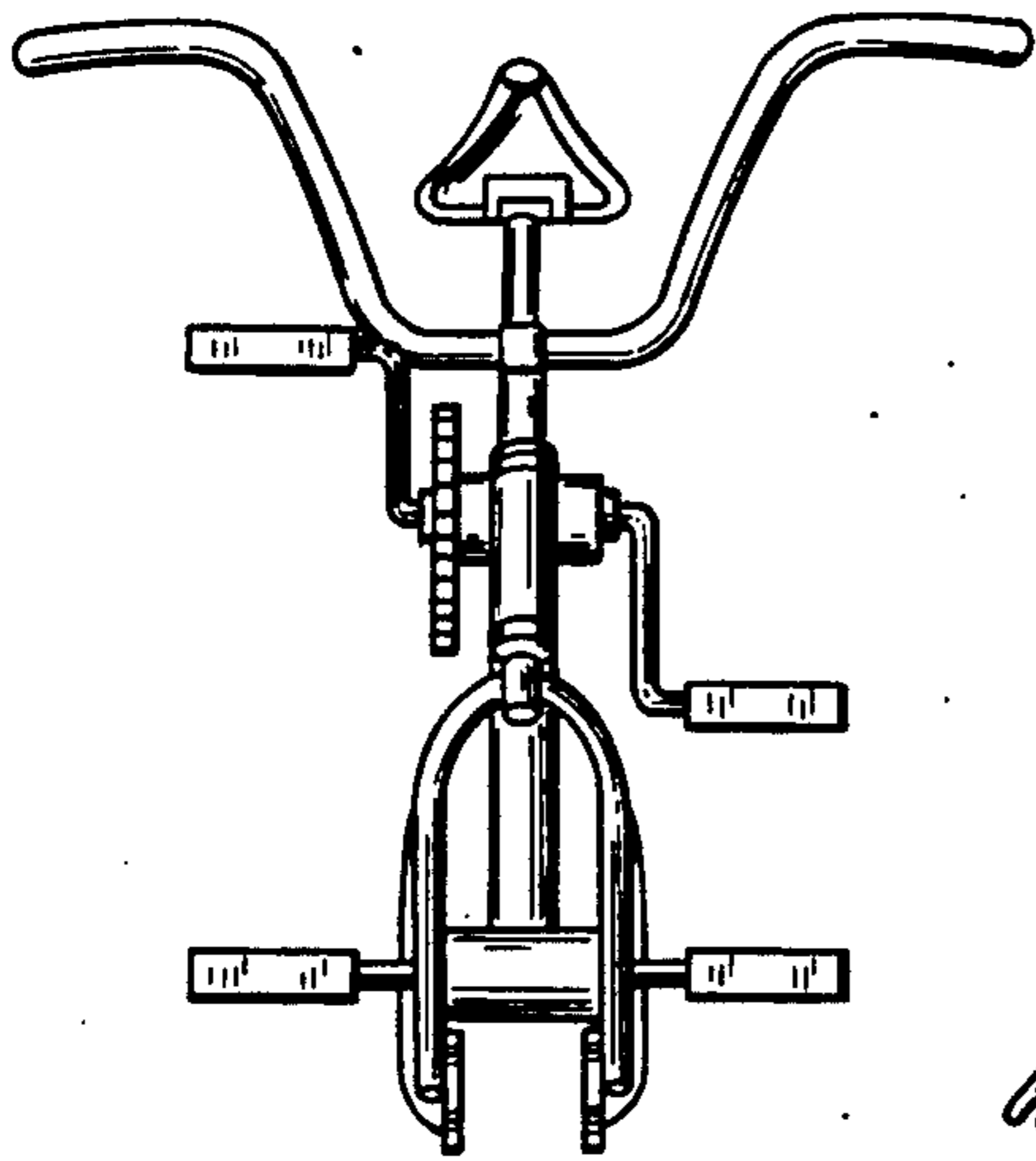

FIG. 3

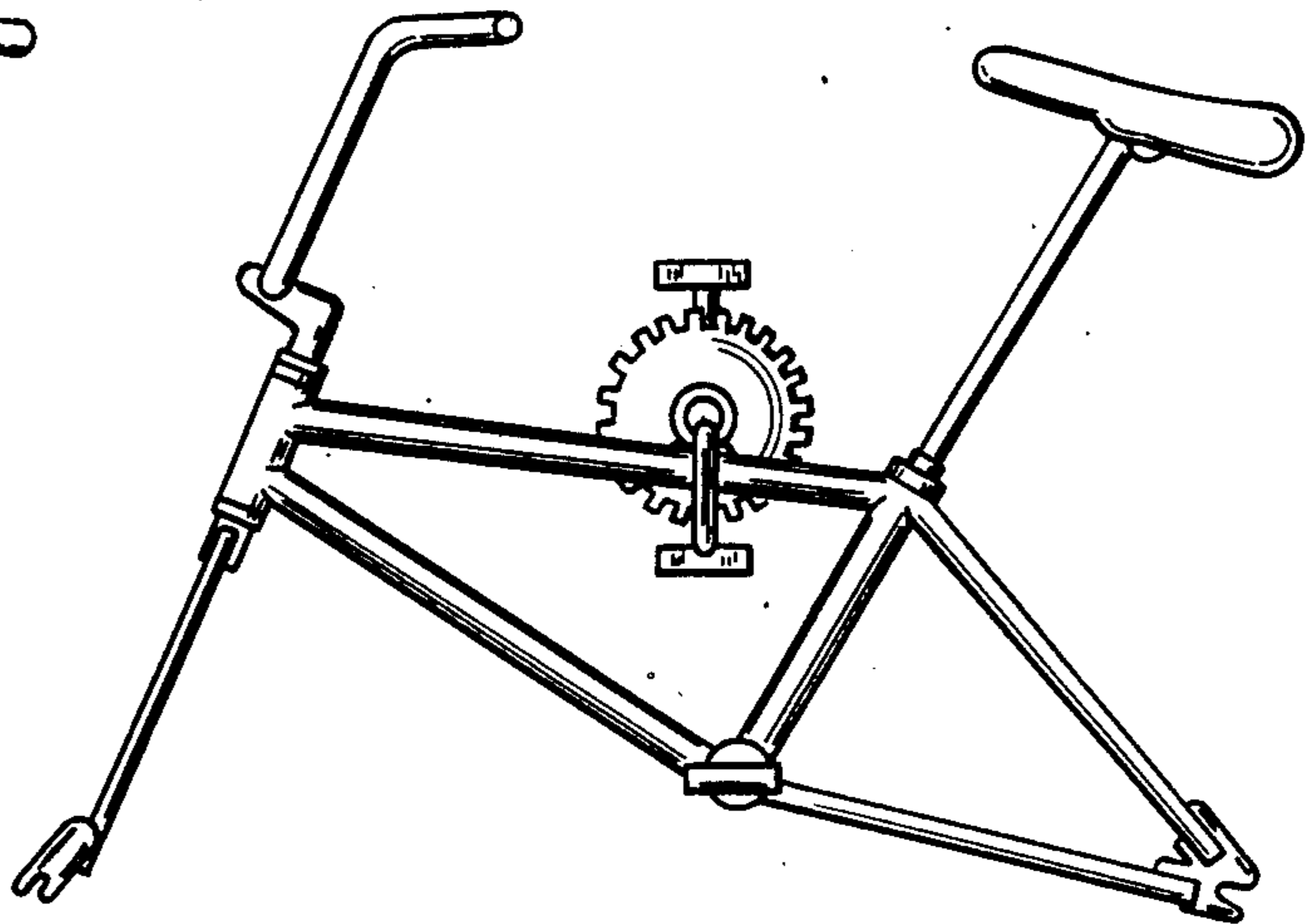

FIG. 4

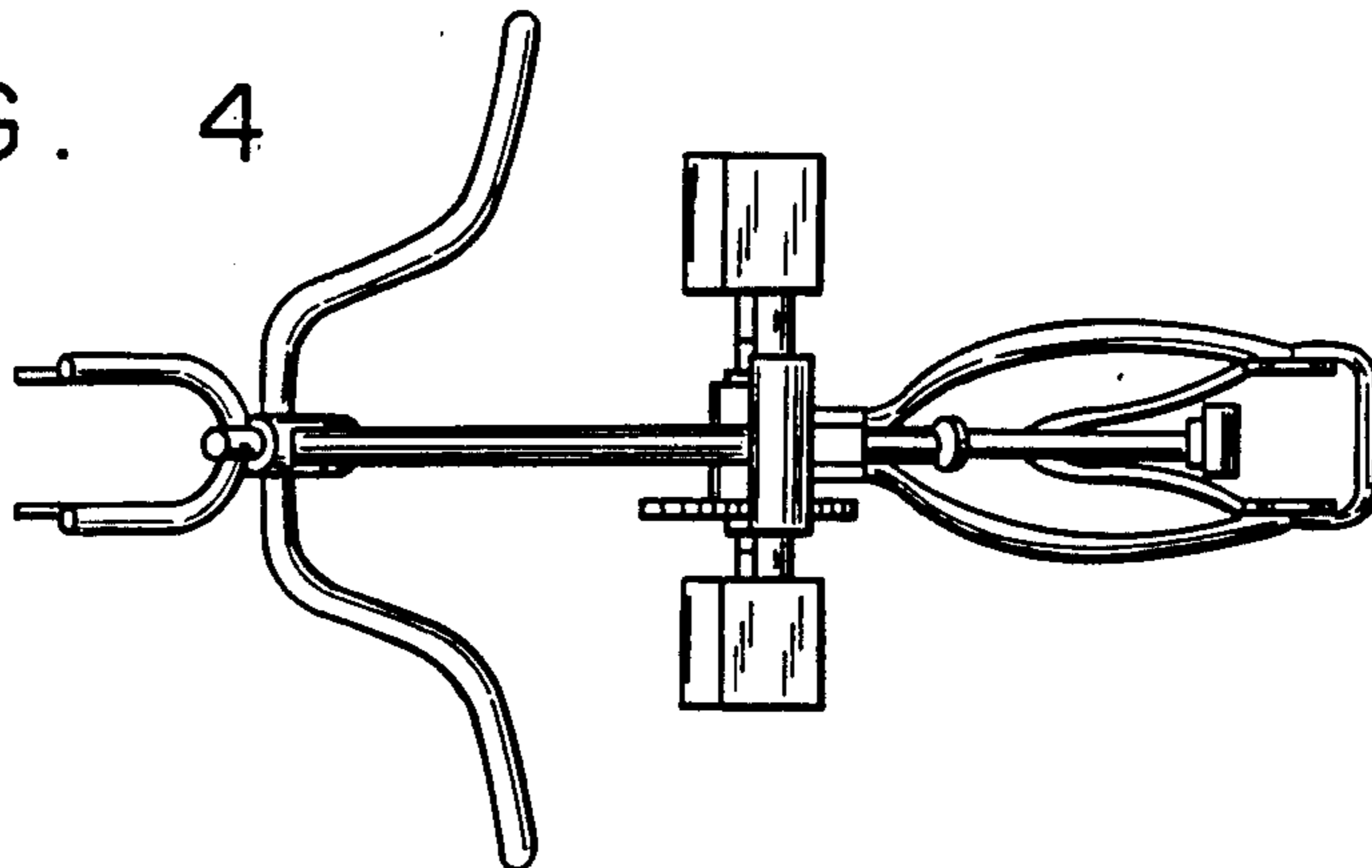

FIG. 5

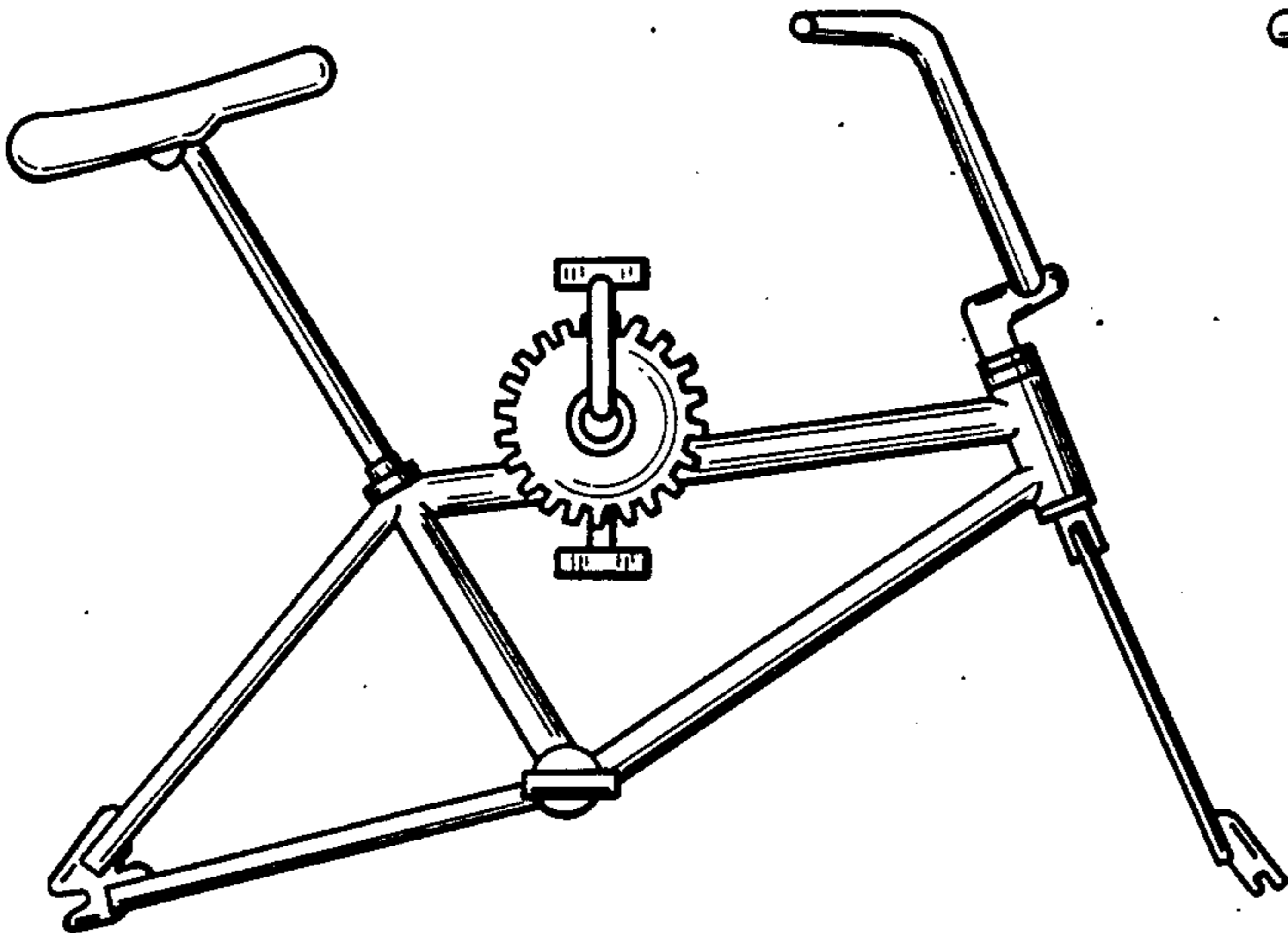

FIG. 6

