

[54] TOY AIRPLANE

[75] Inventor: **Tim J. Harris**, Punnettstown, England

[73] Assignee: **Hestair Kiddicraft Limited**, Bristol, England

[**] Term: **14 Years**

[21] Appl. No.: **354,688**

[22] Filed: **May 19, 1989**

[30] **Foreign Application Priority Data**

Nov. 22, 1988 [GB] United Kingdom 1055143
 [52] U.S. Cl. **D21/90**
 [58] Field of Search D21/87, 90; 446/275, 446/6, 30, 57, 59, 230, 231, 232, 491

[56]

References Cited

U.S. PATENT DOCUMENTS

D. 56,185	8/1920	Monteleone	D21/90
D. 138,778	9/1944	Millstein	D21/90
D. 185,733	7/1959	Cagan et al.	D21/90
D. 265,574	7/1982	Nagode	D21/90
D. 265,841	8/1982	Tung	D21/90
D. 267,501	1/1983	Tabata	D21/90

Primary Examiner—Charles A. Rademaker

[57]

CLAIM

The ornamental design for a toy airplane as shown and described.

DESCRIPTION

FIG. 1 is a perspective view of a toy airplane showing my new design;
 FIG. 2 is a front elevational view thereof;
 FIG. 3 is a rear elevational view thereof;
 FIG. 4 is a right side elevational view thereof;
 FIG. 5 is a left side elevational view thereof;
 FIG. 6 is a top plan view thereof;
 FIG. 7 is a bottom plan view thereof.

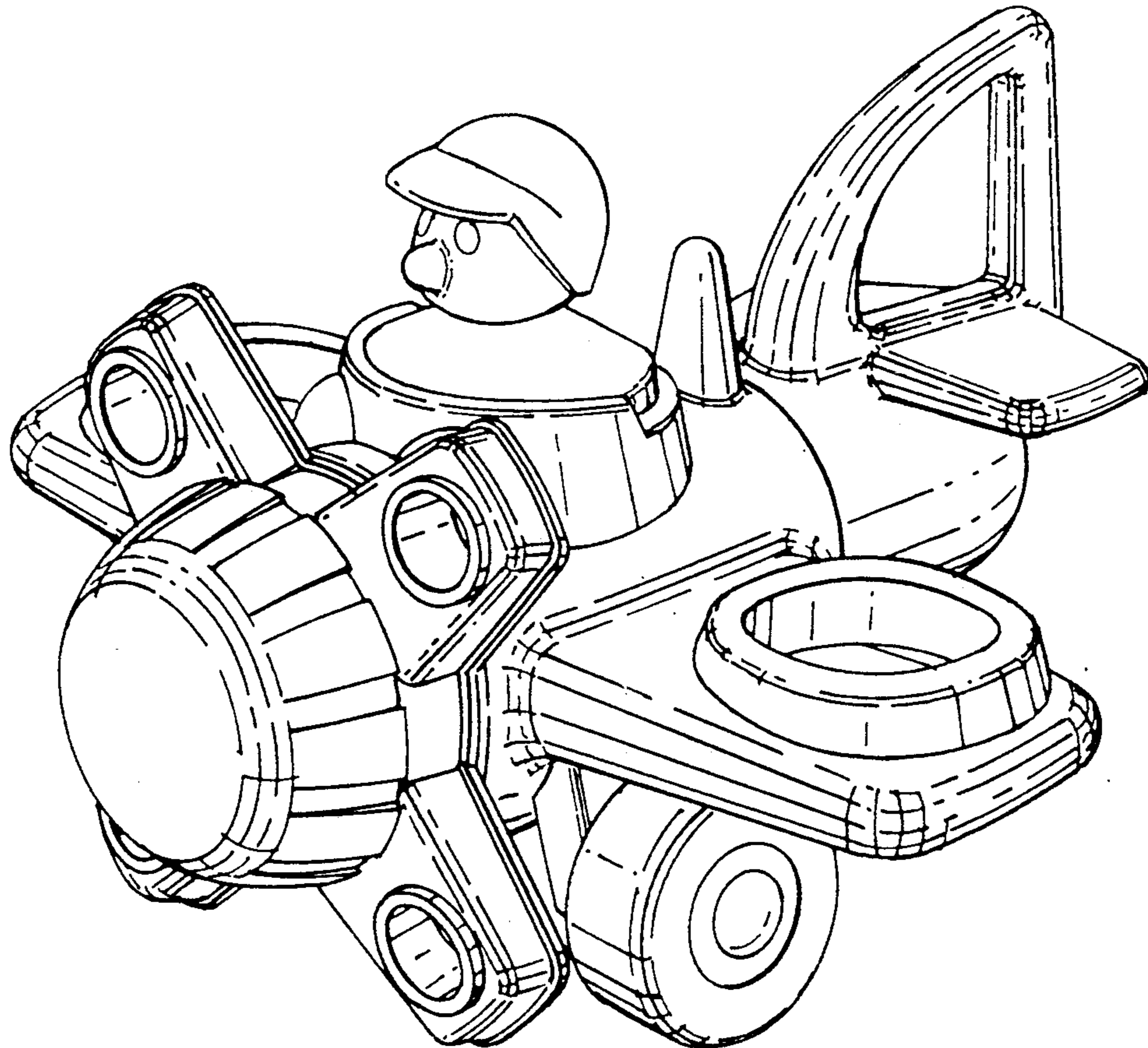
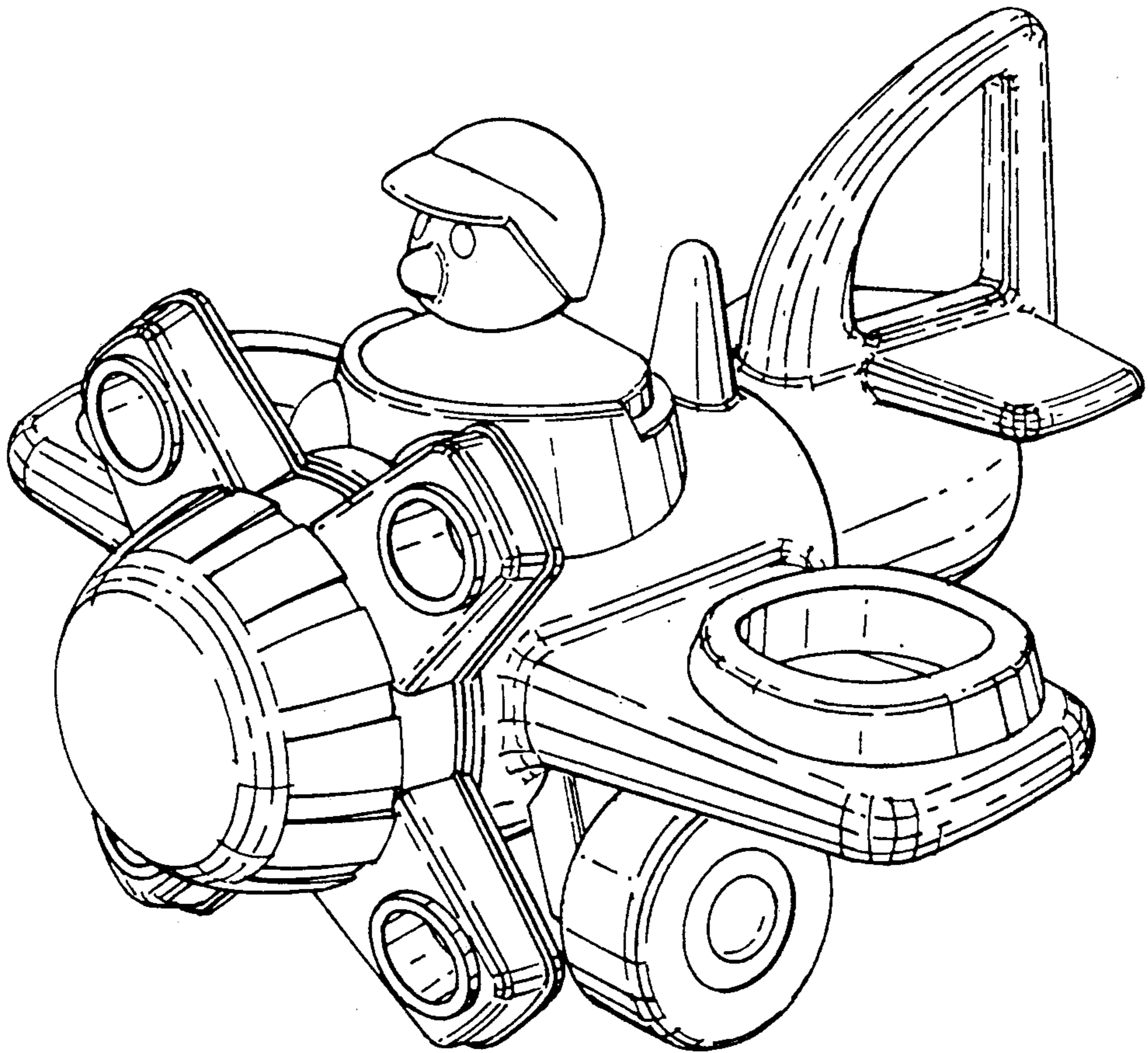

FIG. 1



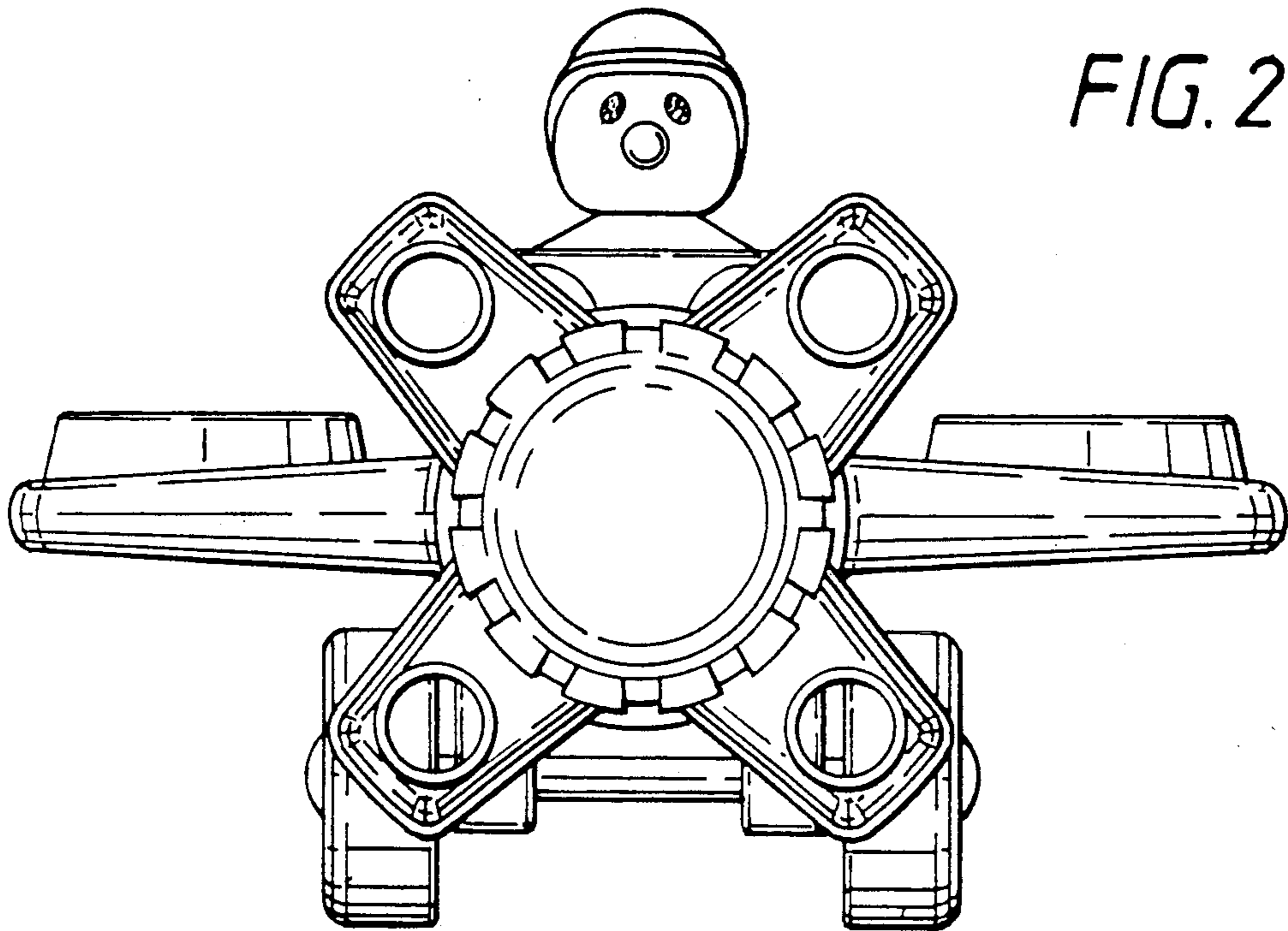

FIG. 2

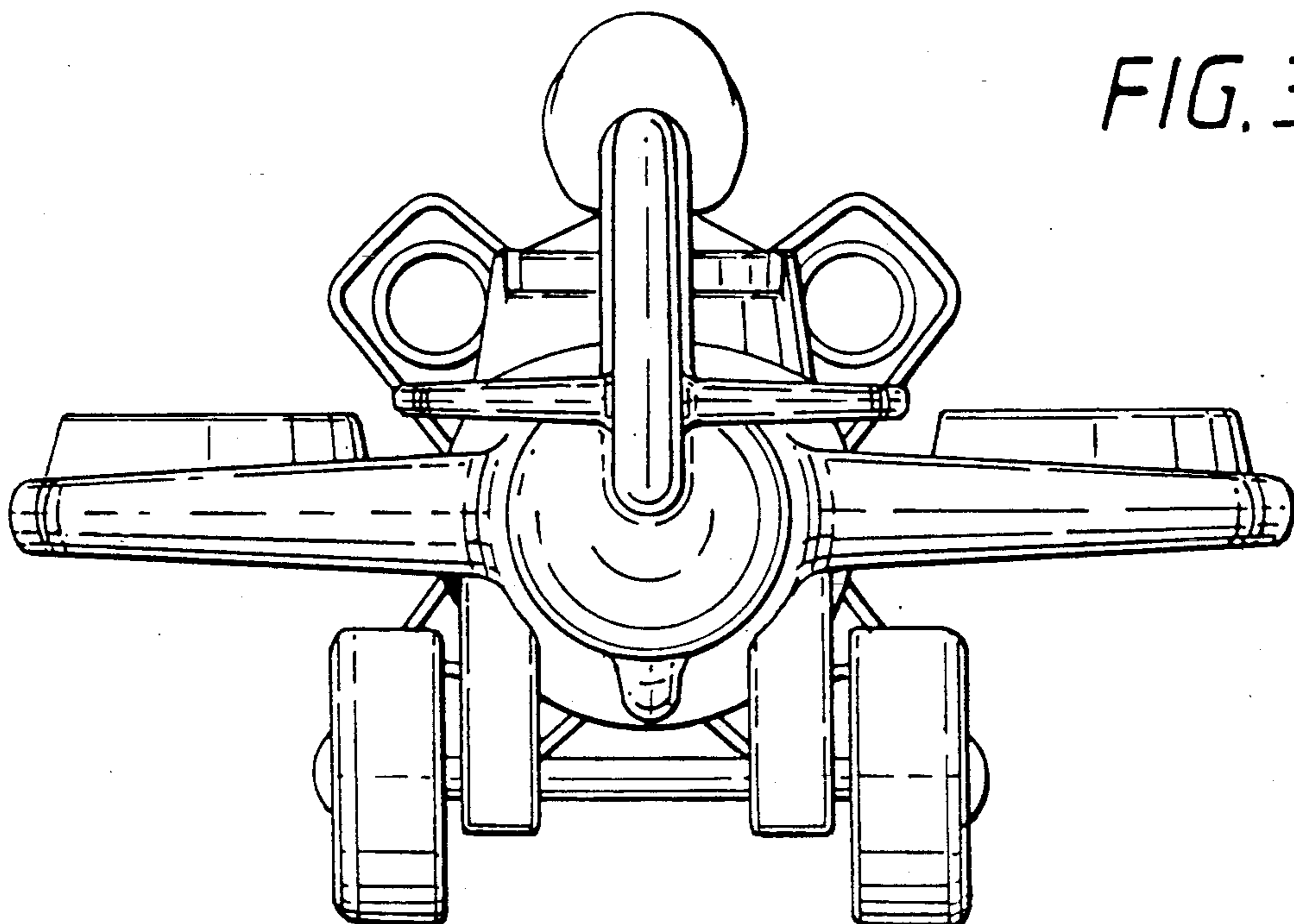

FIG. 3

FIG. 4

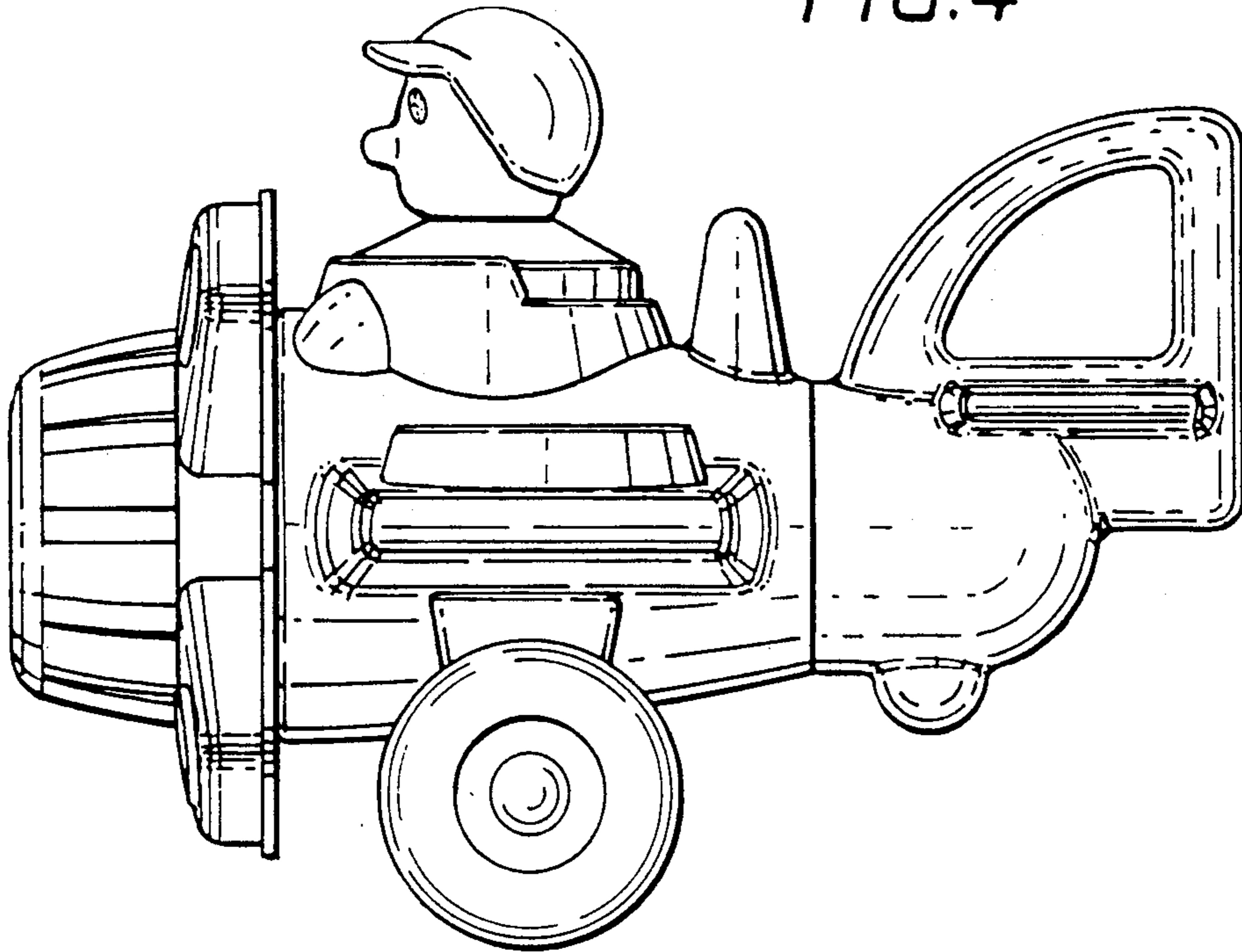

FIG. 5

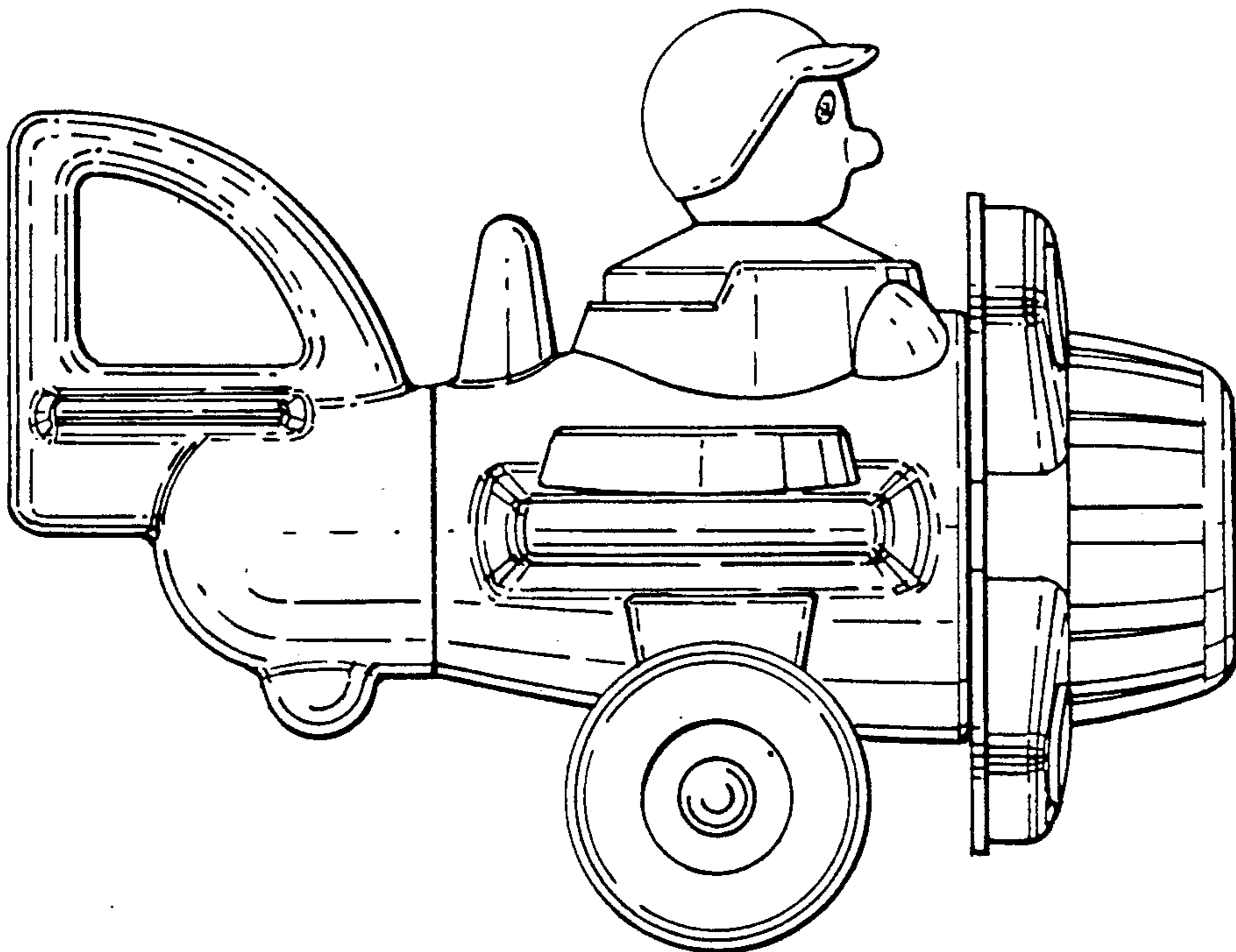

FIG. 6

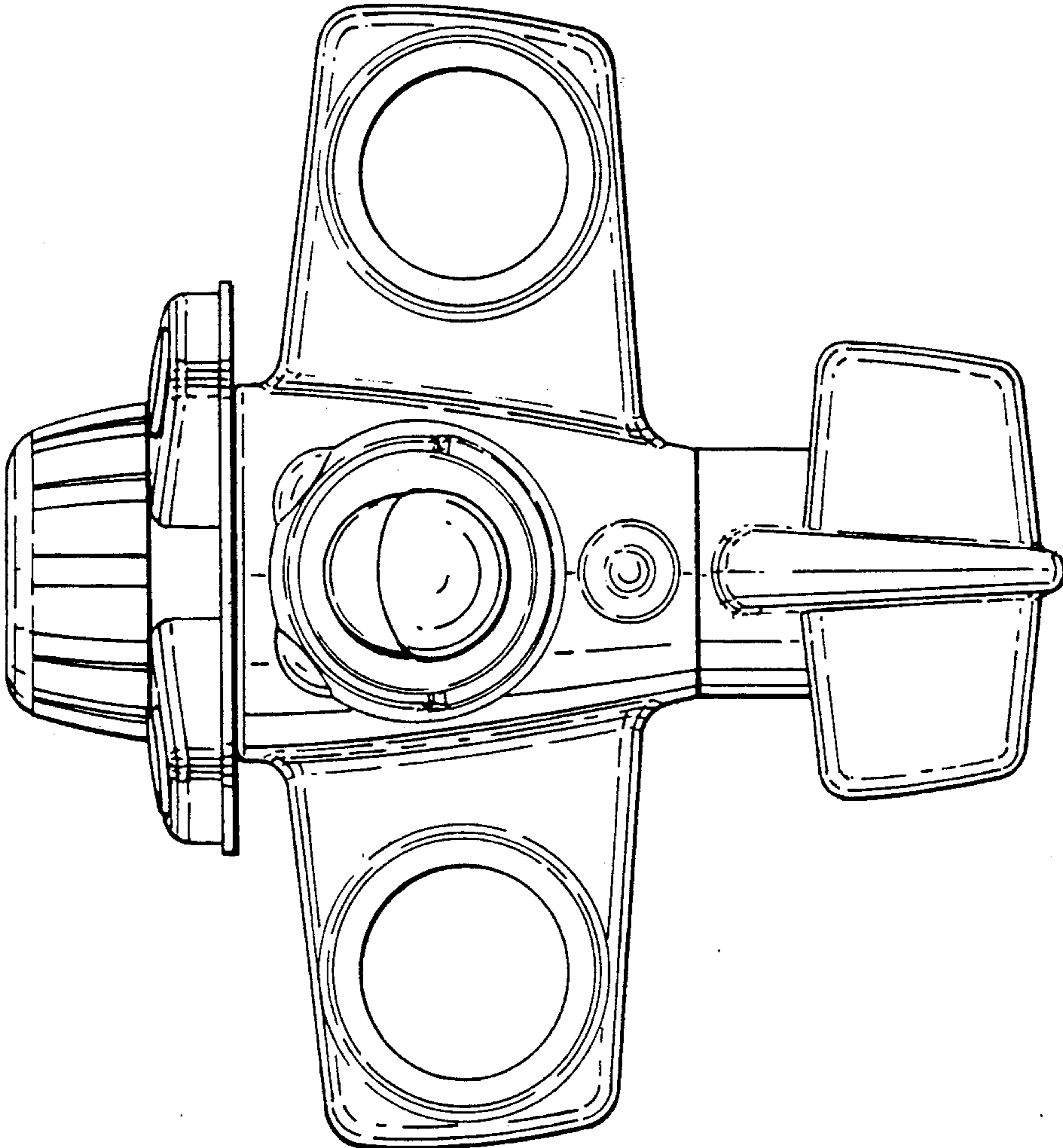

FIG. 7

