

United States Patent [19]

Livingston et al.

[11] Patent Number: **Des. 320,376**

[45] Date of Patent: **** Oct. 1, 1991**

[54] **BOAT WITH L-DRIVE**

[75] Inventors: **David T. Livingston, Seattle; Roger A. Gage, Marysville, both of Wash.**

[73] Assignee: **U.S. Marine Corporation, Hartford, Wis.**

[**] Term: **14 Years**

[21] Appl. No.: **314,834**

[22] Filed: **Feb. 24, 1989**

[52] U.S. Cl. **D12/314; D12/312; D12/313**

[58] Field of Search **D12/300, 310, 311, 313, D12/314, 315, 318; 114/56, 355, 356, 357, 358, 343, 364, 371, 283, 288, 289, 290, 291**

[56] **References Cited**

U.S. PATENT DOCUMENTS

D. 245,409 8/1977 Bostic et al. D12/314

D. 245,902 9/1977 Rogers D12/312
D. 251,834 5/1979 Wood D12/312
D. 296,206 6/1988 Arima D12/313

*Primary Examiner—Kay H. Chin
Attorney, Agent, or Firm—Lewis L. Lloyd*

[57] CLAIM

The ornamental design for a boat with L-drive, as shown and described.

DESCRIPTION

FIG. 1 is a top and rear perspective view of a boat with L-drive showing our new design;
FIG. 2 is a side elevational view thereof, the opposite side view being a mirror image of that shown;
FIG. 3 is a top plan view thereof;
FIG. 4 is a bottom plan view thereof;
FIG. 5 is a bottom and rear perspective view thereof;
FIG. 6 is a rear elevational view thereof; and
FIG. 7 is a front elevational view thereof.

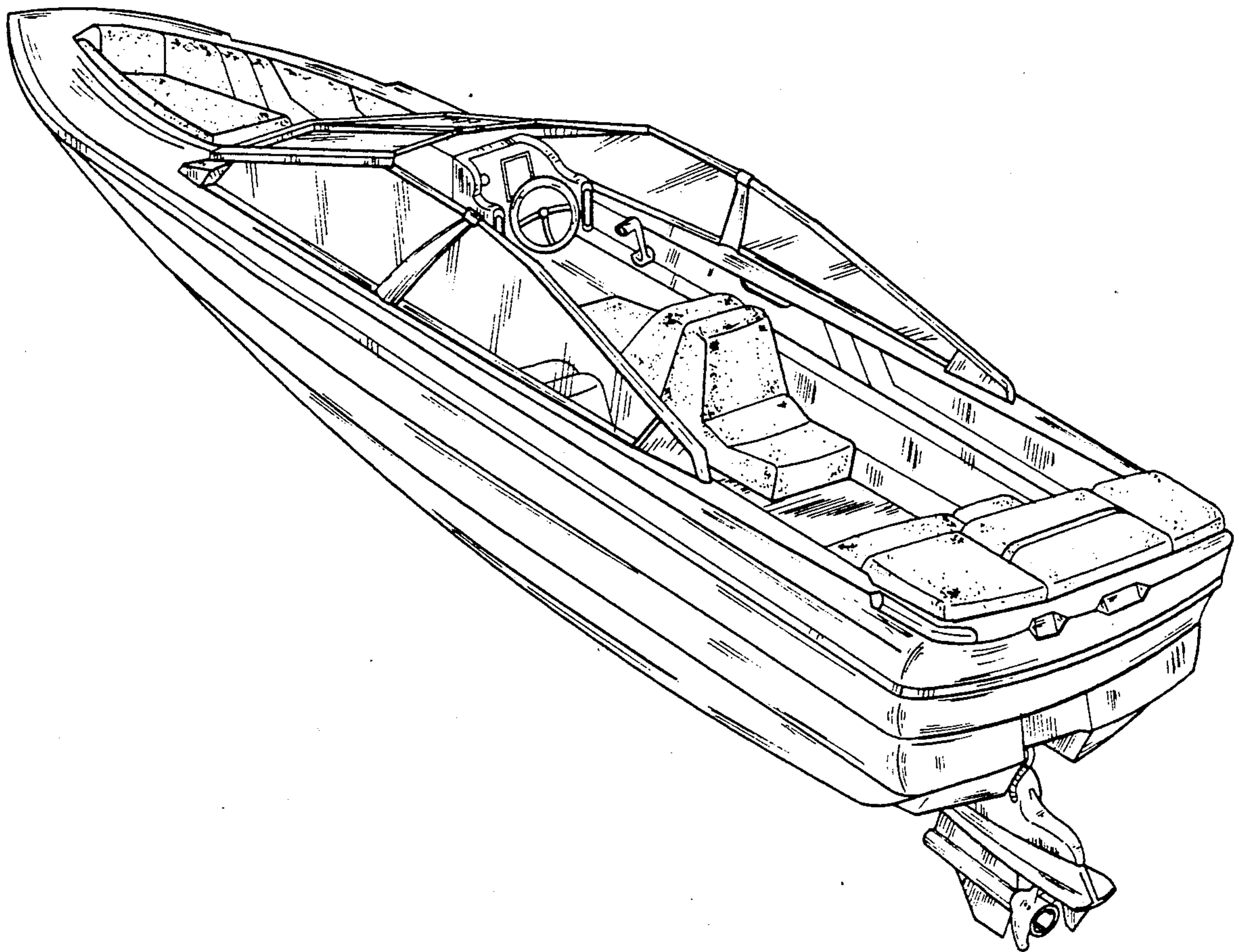

FIG. 1

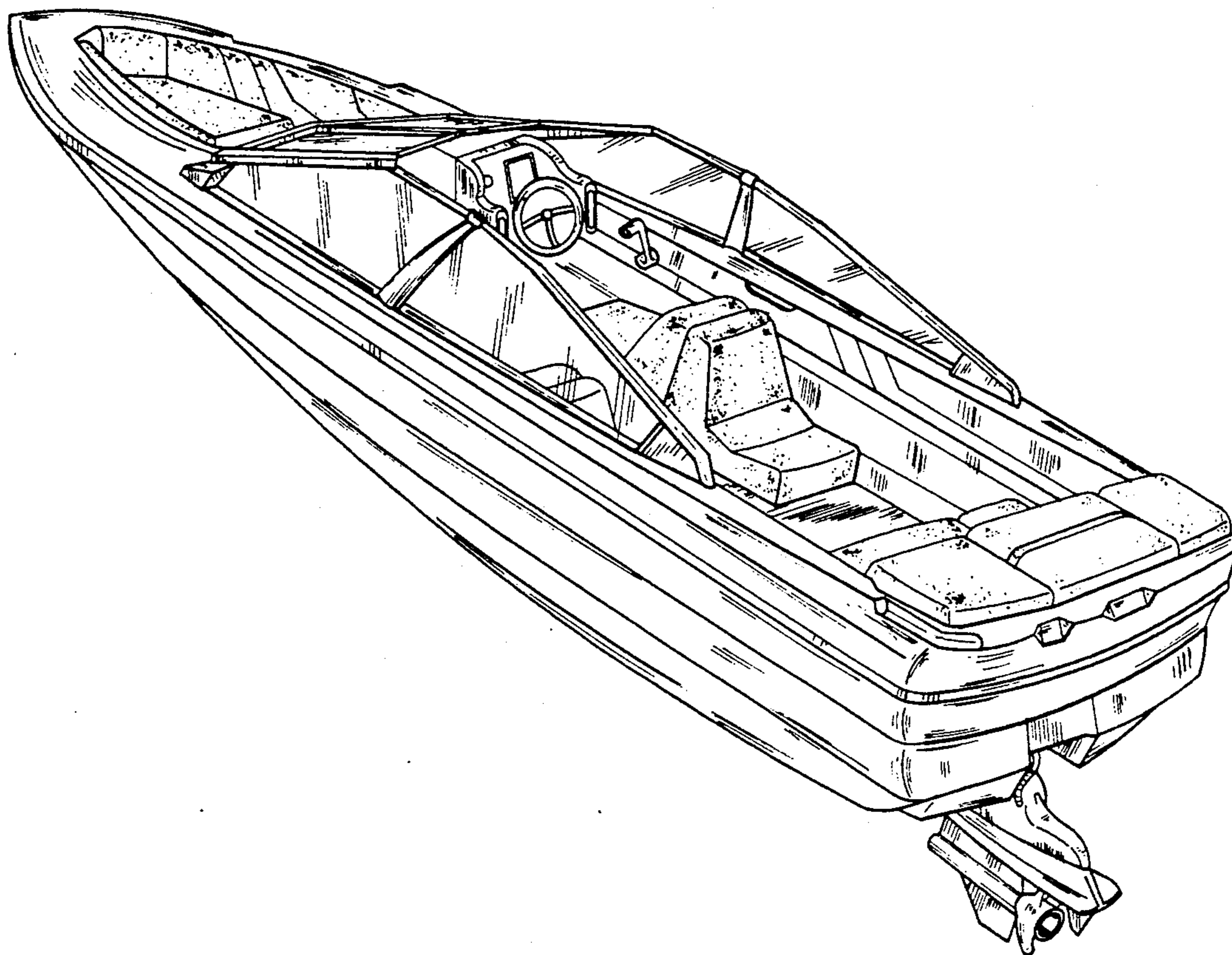

FIG. 2

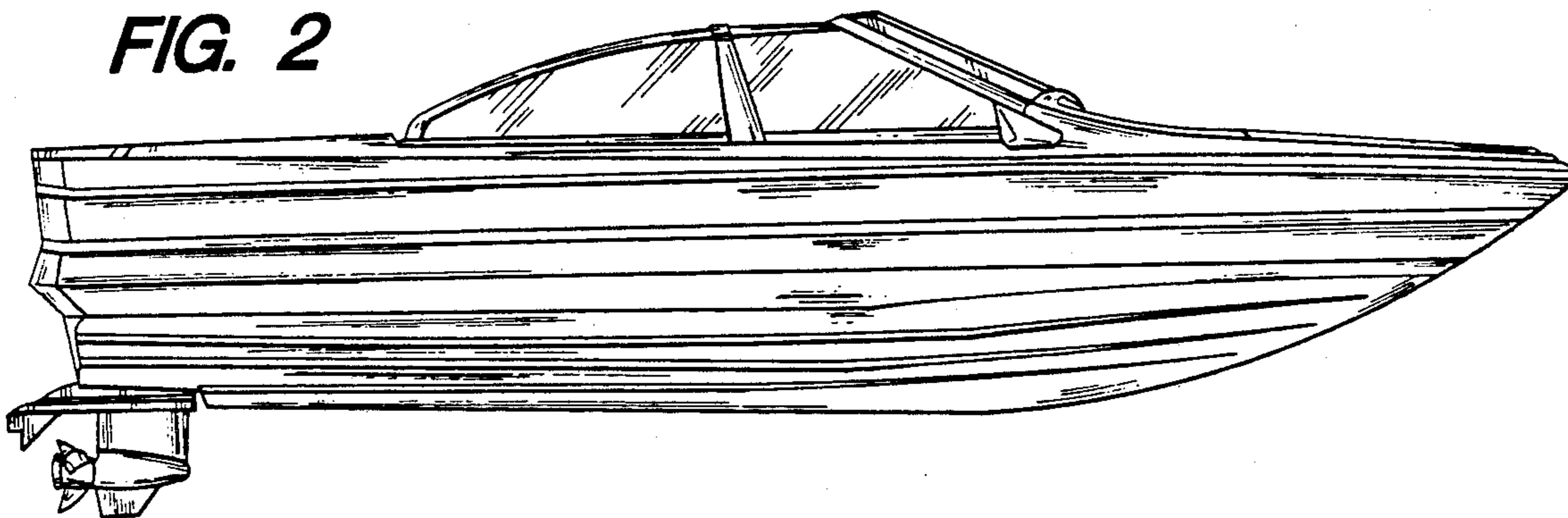

FIG. 3

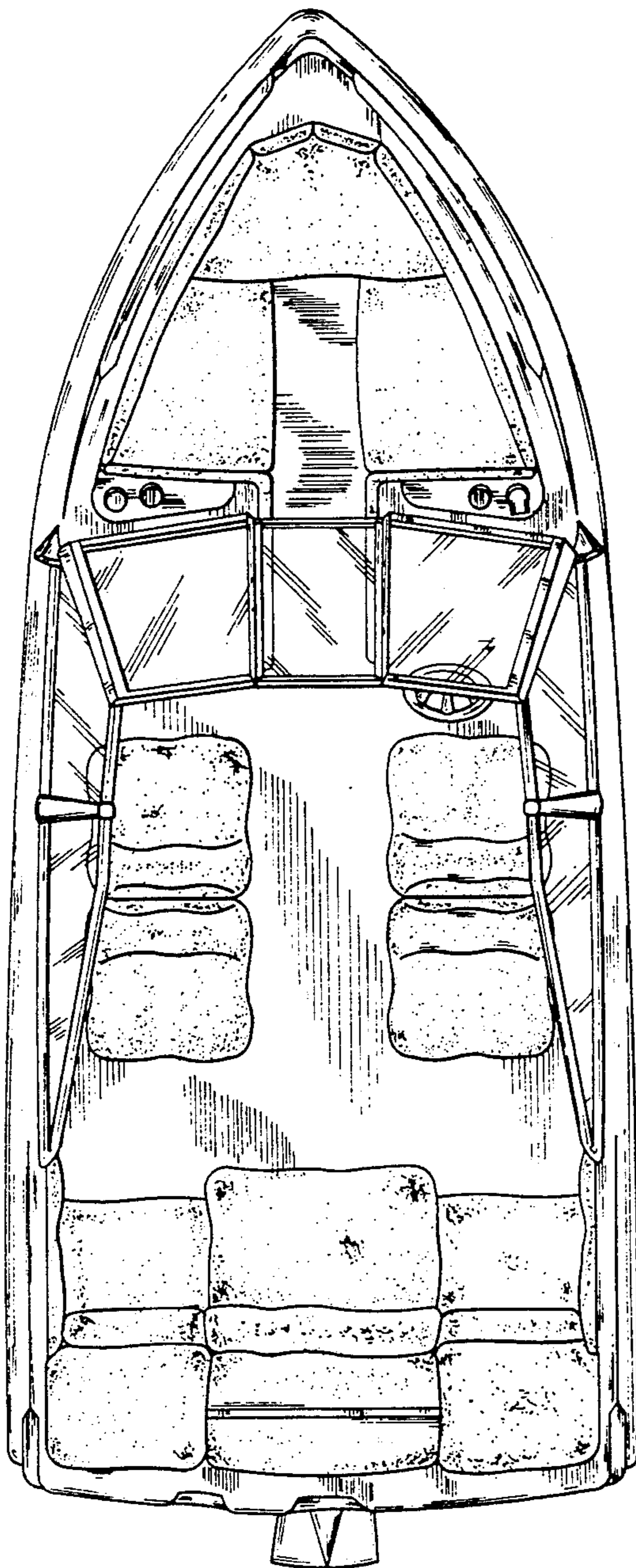
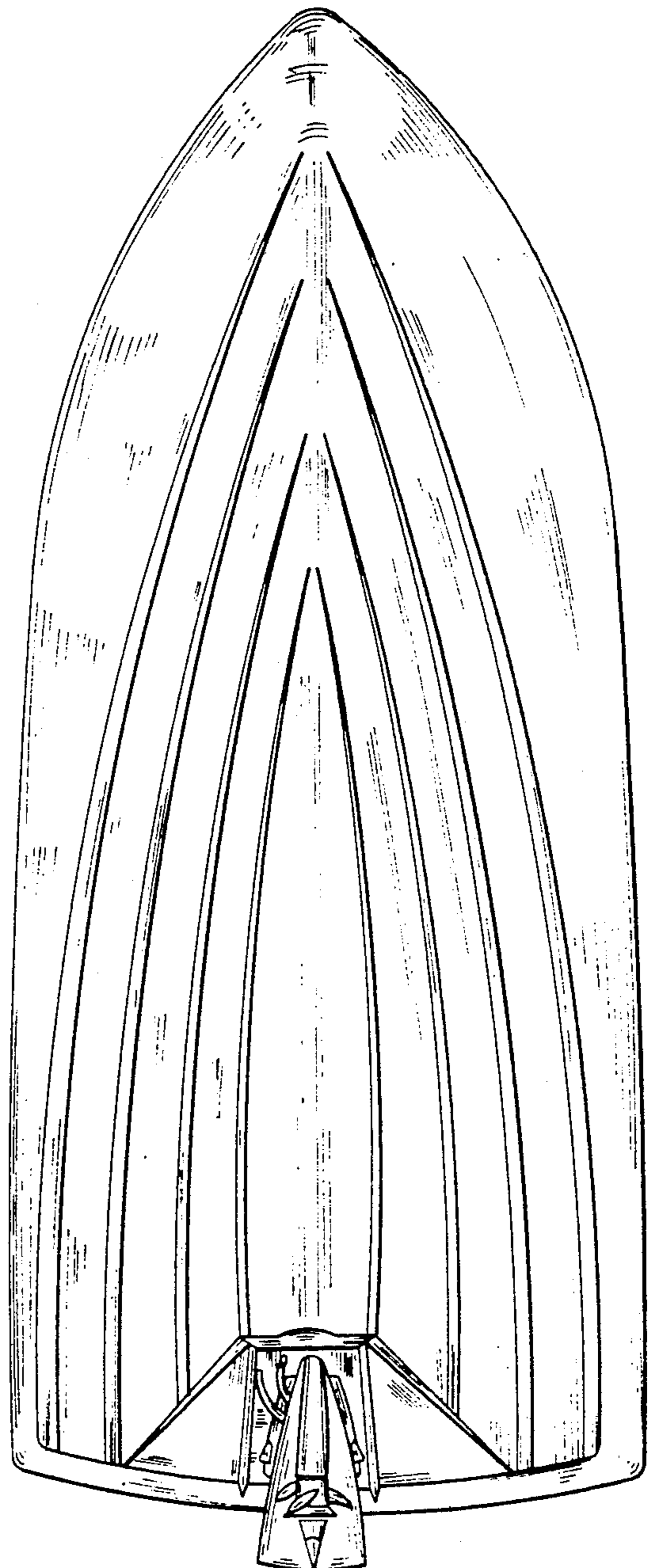

FIG. 4



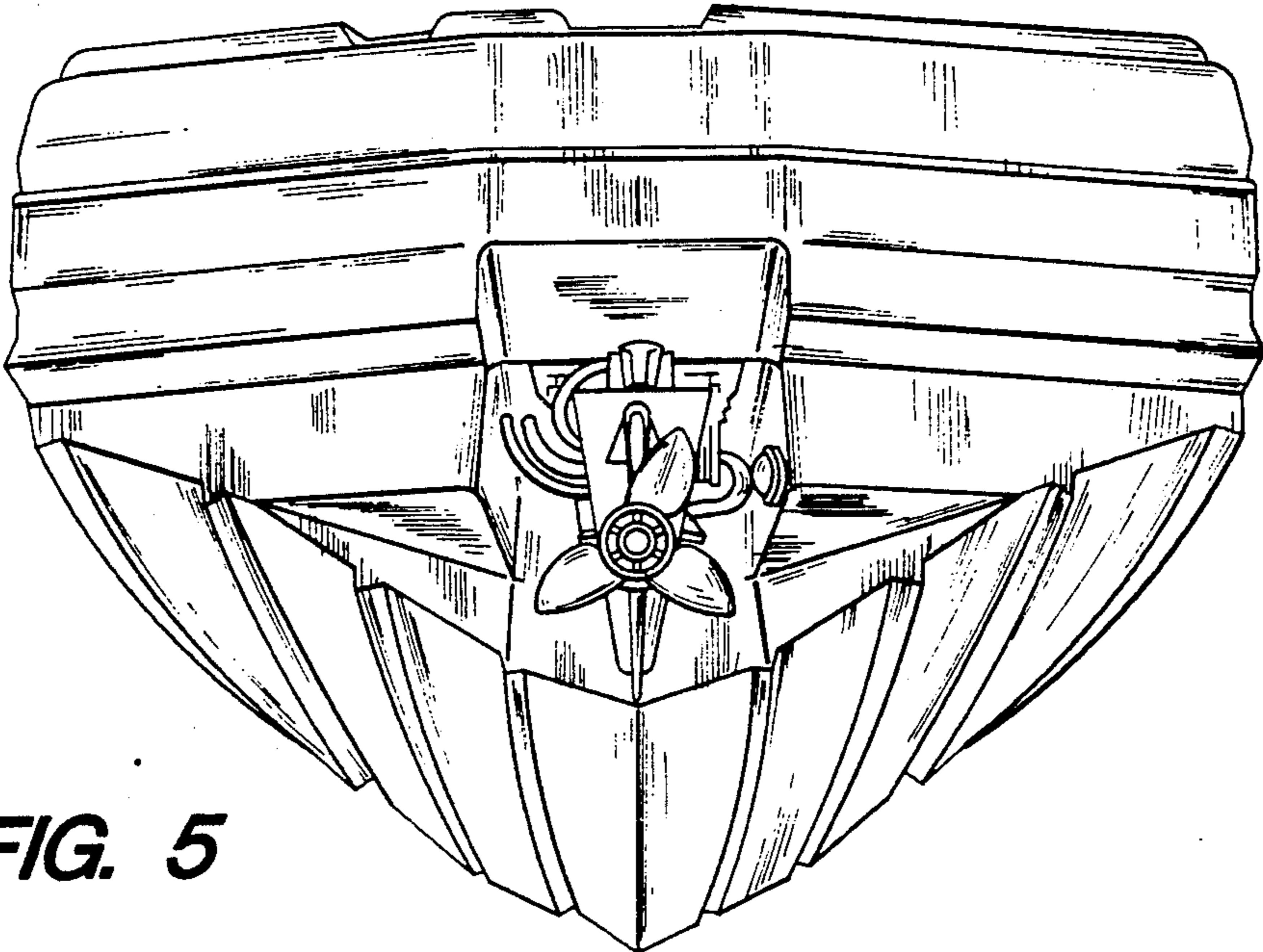

FIG. 5

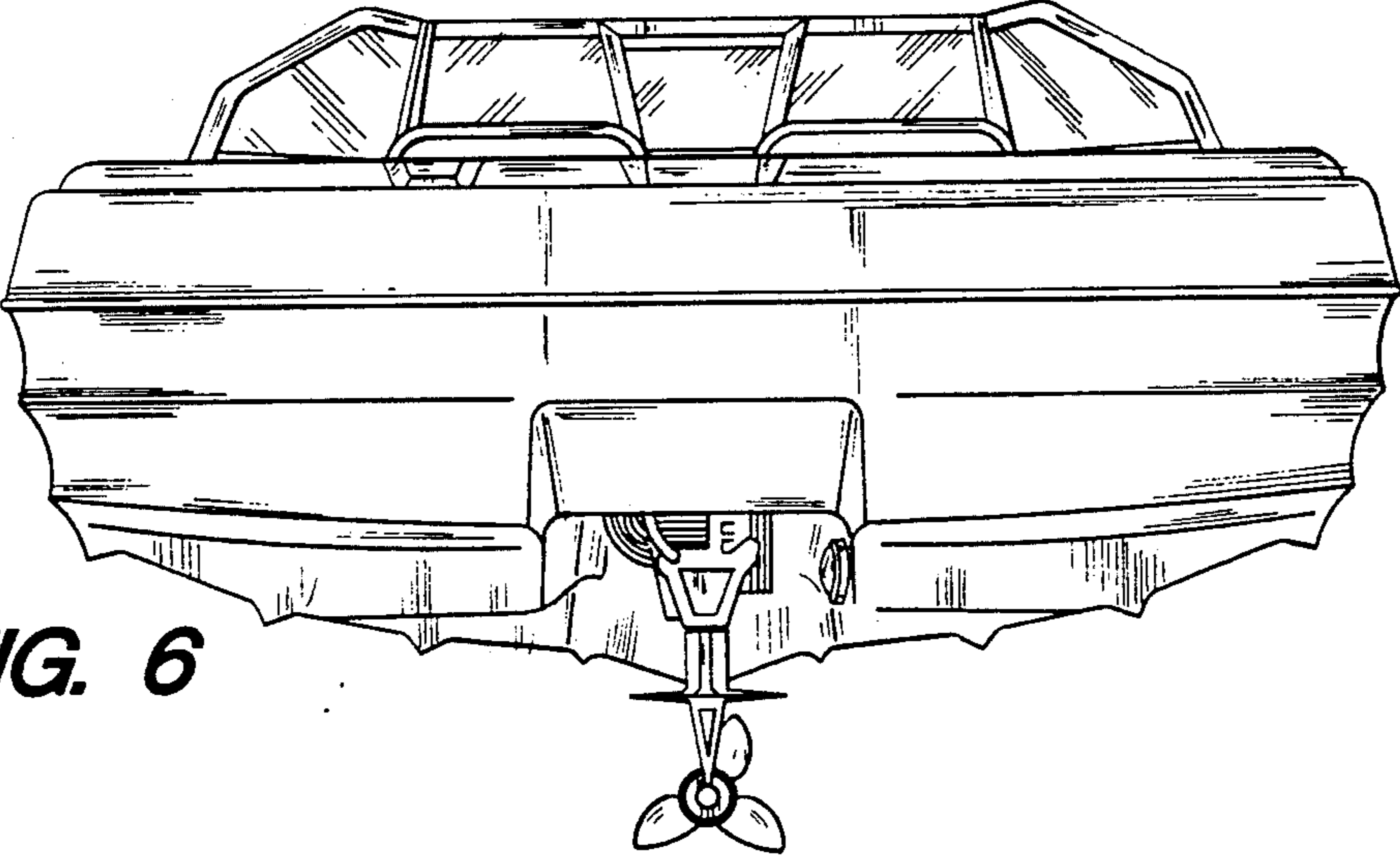

FIG. 6

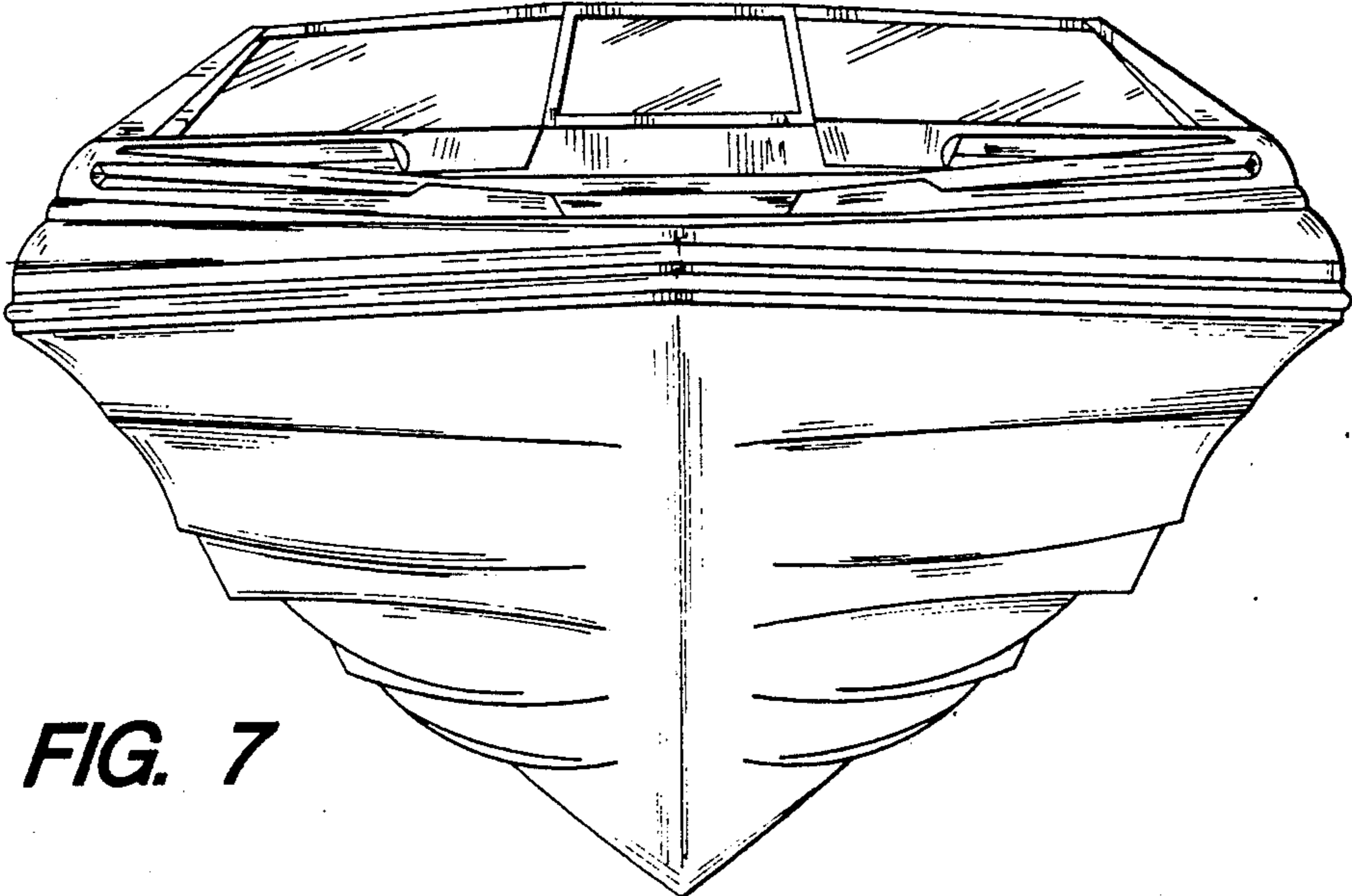

FIG. 7