

[54] AIRCRAFT

[76] Inventor: Gerald A. Wiegert, 400 N. Marine Ave., Wilmington, Calif. 90744

[**] Term: 14 Years

[21] Appl. No.: 193,999

[22] Filed: May 13, 1988

[52] U.S. Cl. D12/333; D12/319; D12/338

[58] Field of Search D12/319, 326, 333, 339, D12/344, 338, 342, 343; 244/15, 199, 53 B, 55, 91

[56] References Cited

U.S. PATENT DOCUMENTS

D. 239,522	4/1976	Wheatley	D12/339
D. 245,157	7/1977	Seidel	D12/333
D. 246,298	11/1977	Hansen	D12/333
3,576,300	4/1971	Palfreyman	244/55
4,848,702	7/1989	Riggins	D12/344

OTHER PUBLICATIONS

Flight Int'l, p. 339, Jan. 13, 1982, "IML Group AXM".
Flight Int'l, Jun. 13, 1981, p. 1877, "Circa 2080".

Primary Examiner—Kay H. Chin
Attorney, Agent, or Firm—Benman & Collins

[57] CLAIM

The ornamental design for an aircraft, as shown and described.

DESCRIPTION

FIG. 1 is a front, top and left side perspective view of an aircraft showing my new design;
FIG. 2 is a left side elevational view thereof, the right side view being a mirror image of that shown;
FIG. 3 is a top plan view thereof;
FIG. 4 is a front elevational view thereof;
FIG. 5 is a bottom plan view thereof;
FIG. 6 is a rear elevational view thereof; and
FIG. 7 is a front, bottom and left perspective view thereof.

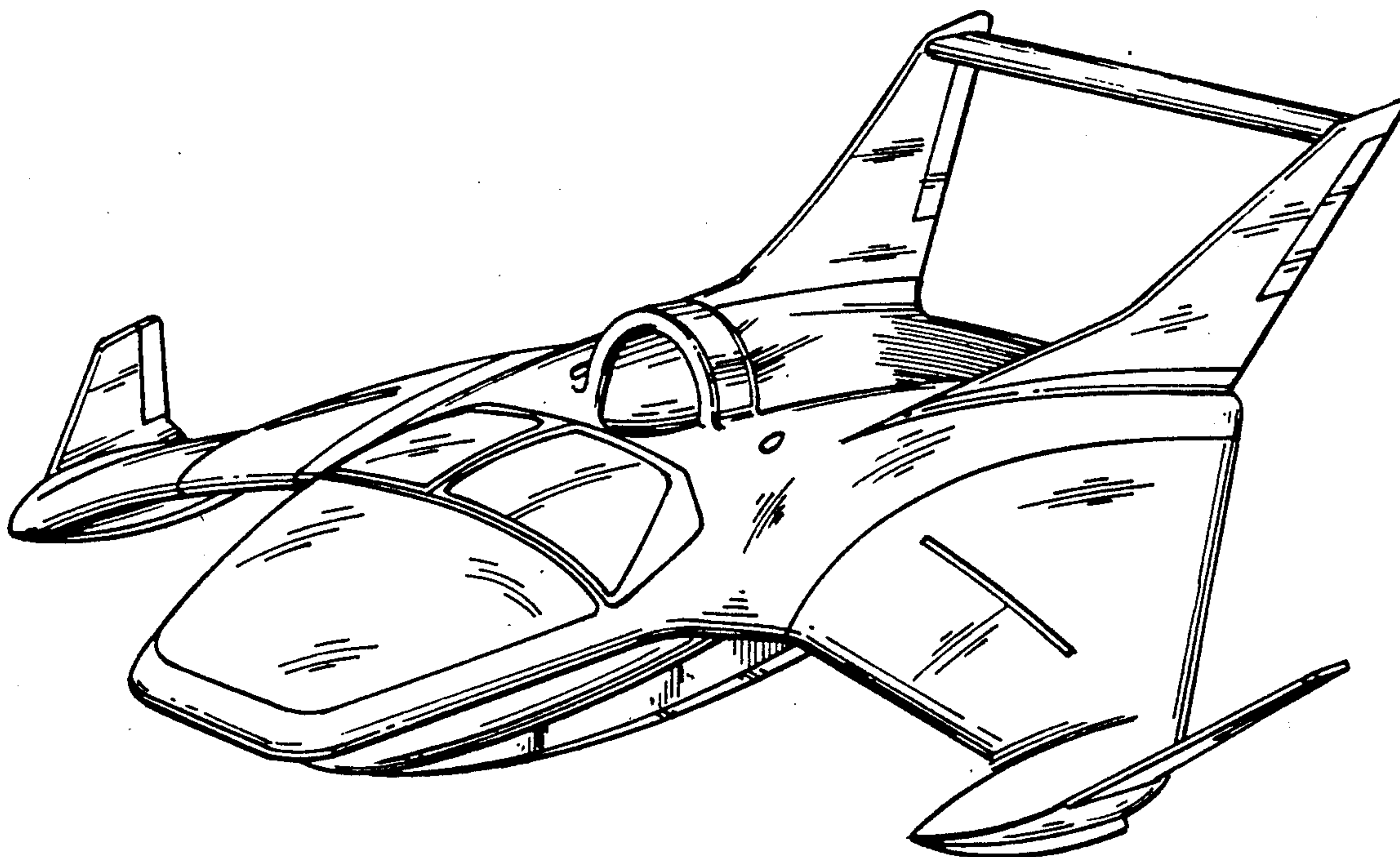

FIG. 1

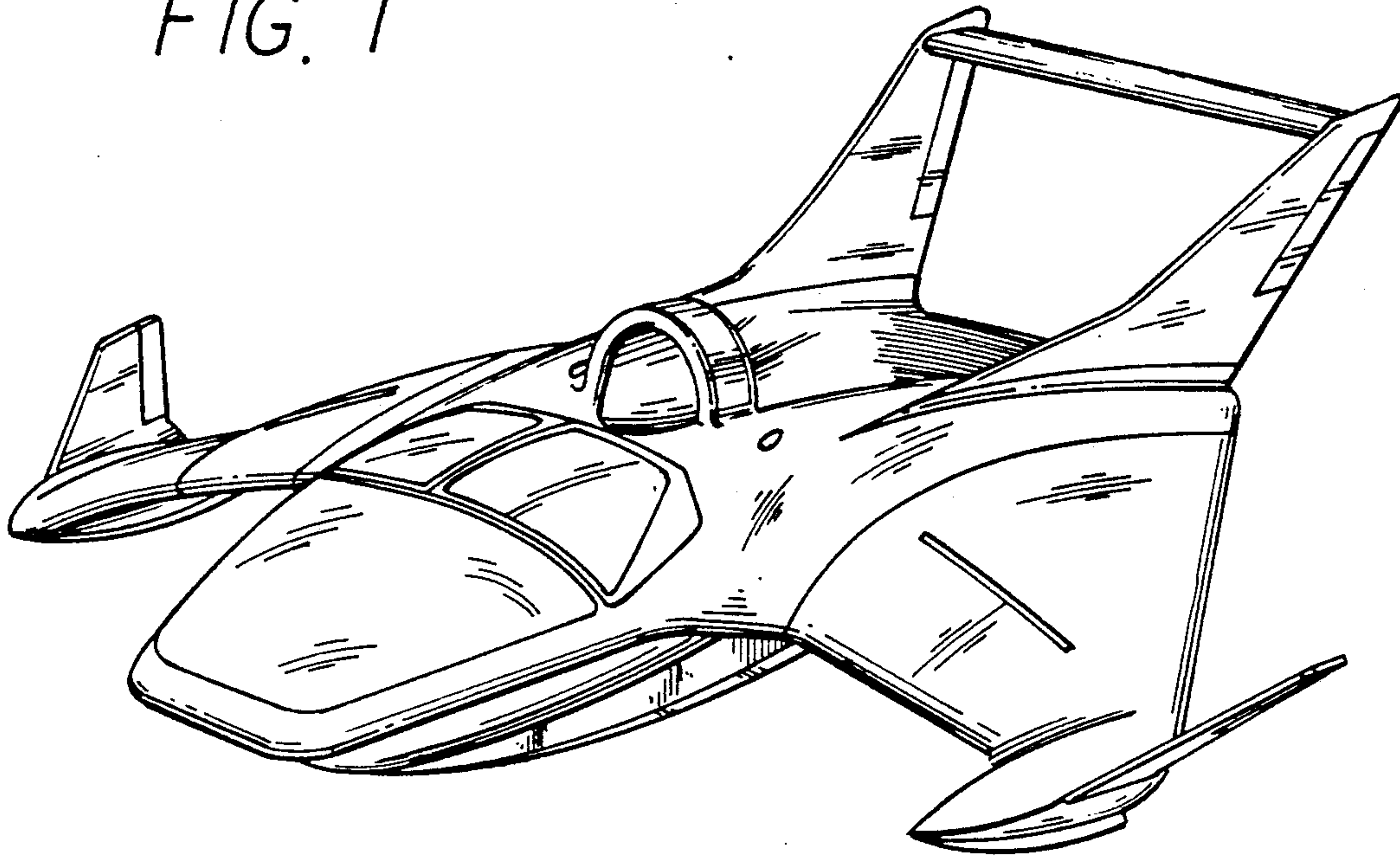
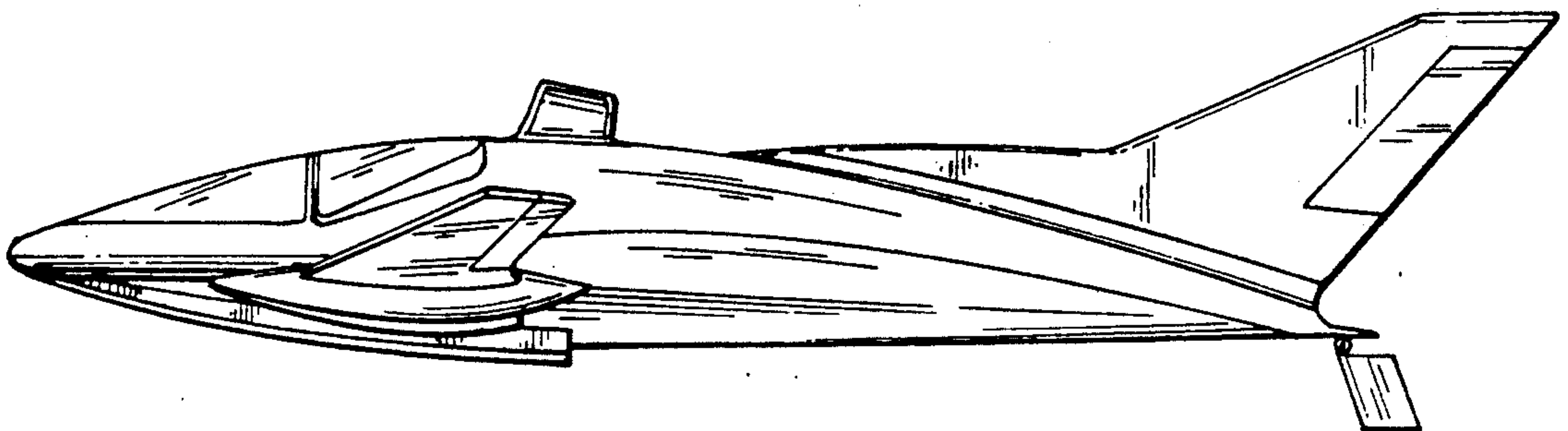

FIG. 2



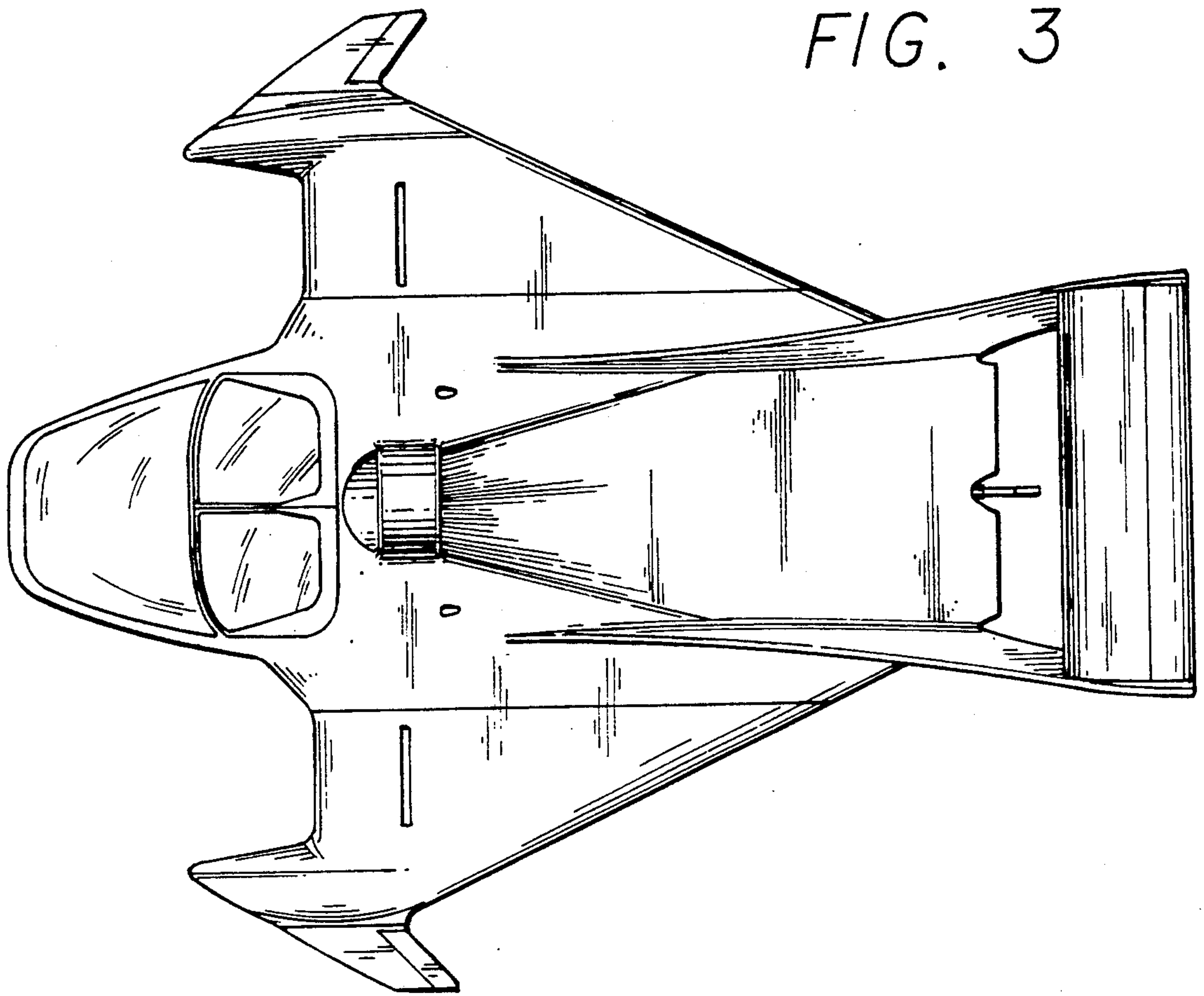

FIG. 3

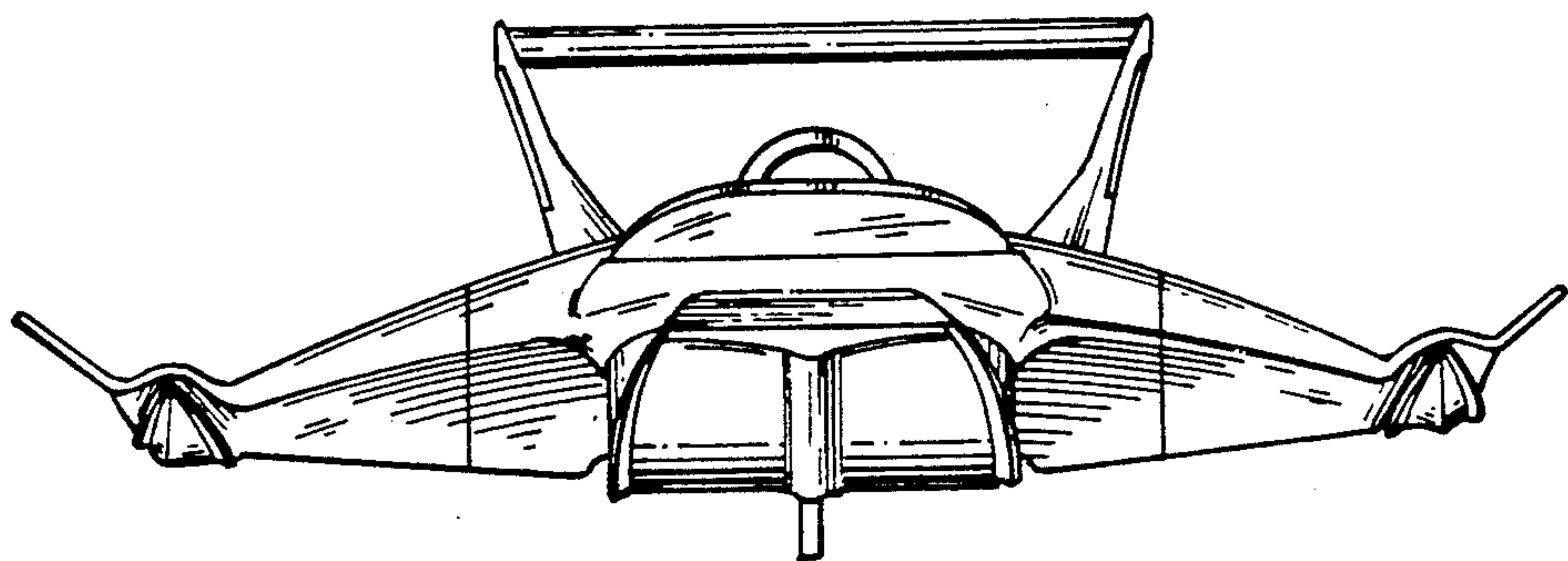

FIG. 4

FIG. 5

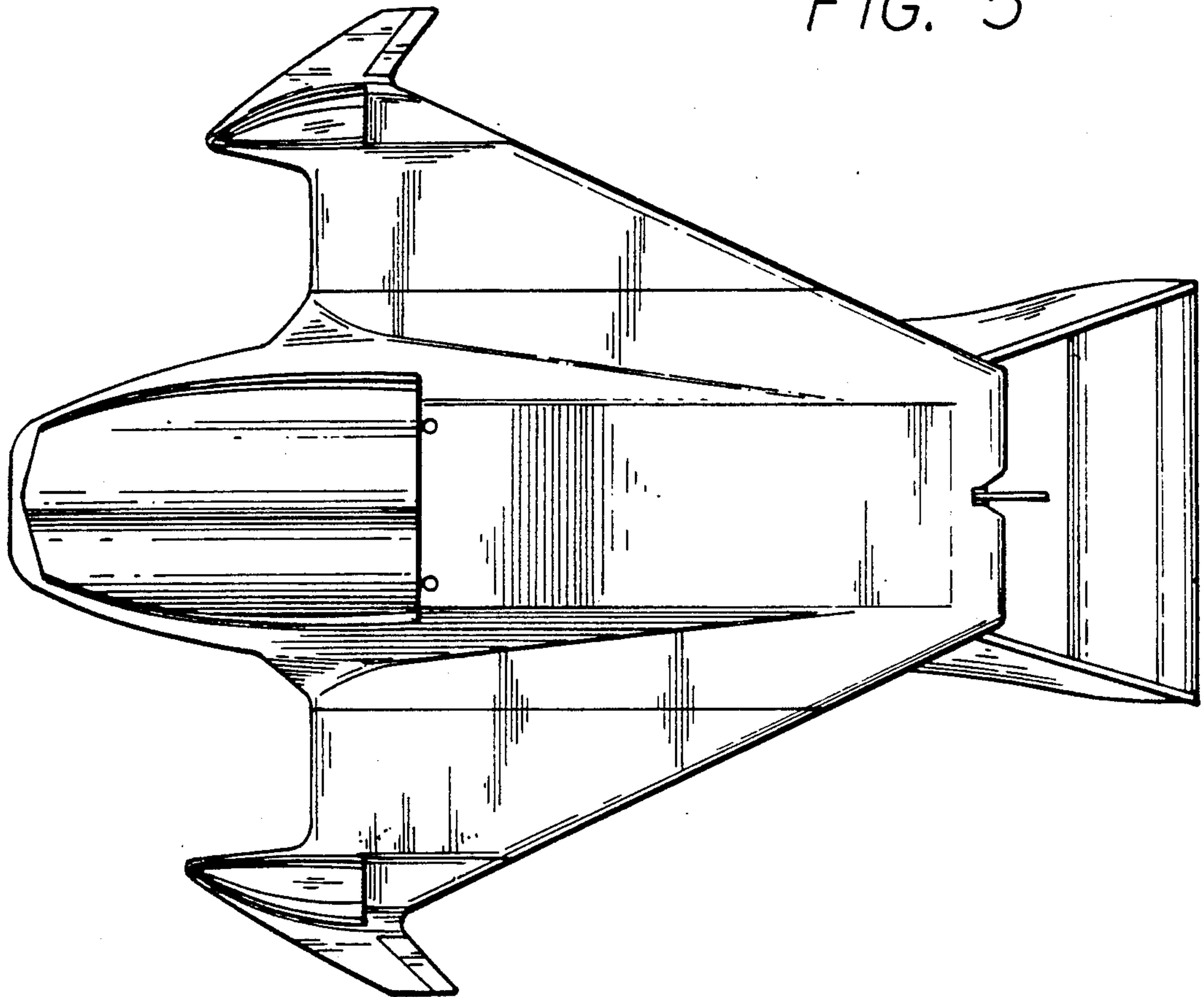
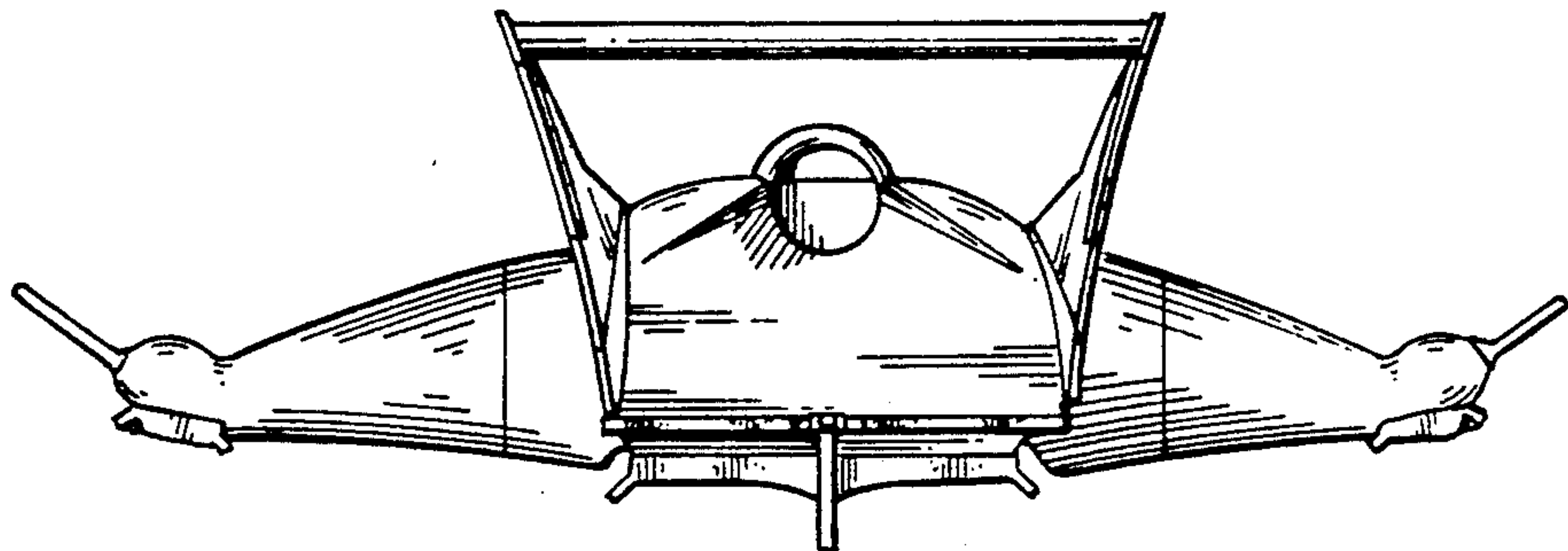

FIG. 6



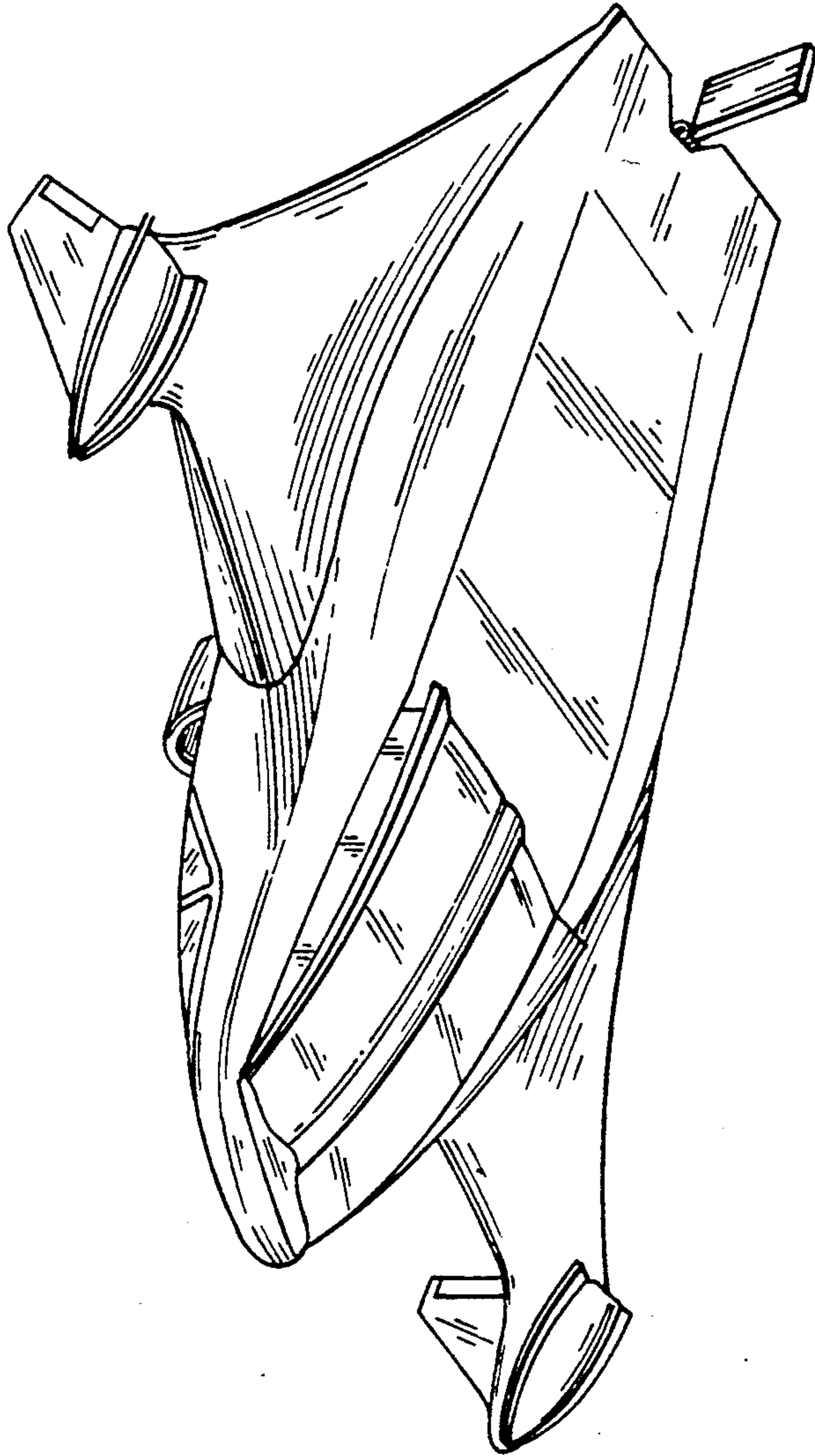

FIG. 7