

United States Patent [19]

Bennett et al.

[11] Patent Number: **Des. 319,571**

[45] Date of Patent: **** Sep. 3, 1991**

[54] **TIE DOWN ANCHOR FOR PICKUP TRUCKS**

[75] Inventors: **Vernon N. Bennett, Des Moines;**
Dennis R. Cox, Pleasantville, both of
Iowa

[73] Assignee: **Professional Advisory & Distribution**
Company, Des Moines, Iowa

[**] Term: **14 Years**

[21] Appl. No.: **225,144**

[22] Filed: **Jul. 28, 1988**

[52] U.S. Cl. **D8/356**

[58] Field of Search **D8/349, 354, 356, 367,**
D8/382, 396; 410/101, 113, 110-112, 109, 116,
96, 106; 248/231.91, 231.9, 499, 503; 24/616;
296/43

[56] **References Cited**

U.S. PATENT DOCUMENTS

D. 219,767 1/1971 Johnson D8/367
D. 283,006 3/1986 Carter, Jr. et al. D8/349

1,535,128 4/1925 Milner 296/43
3,595,125 7/1971 Jacobs 410/106
4,191,108 3/1980 Jones 410/113 X
4,316,688 2/1982 Roskelley 410/116 X
4,607,991 8/1986 Porter 410/110
4,685,646 8/1987 Harrison 248/499 X

Primary Examiner—Wallace R. Burke
Assistant Examiner—Freda S. Nunn
Attorney, Agent, or Firm—Zarley, McKee, Thomte,
Voorhees & Sease

[57] CLAIM

The ornamental design for a tie down anchor for pickup trucks, as shown.

DESCRIPTION

FIG. 1 is a perspective view of a tie down anchor for pickup trucks showing our new design;
FIG. 2 is a front elevational view thereof;
FIG. 3 is a rear elevational view thereof;
FIG. 4 is a top plan view thereof;
FIG. 5 is a bottom plan view thereof;
FIG. 6 is an end elevational view thereof.

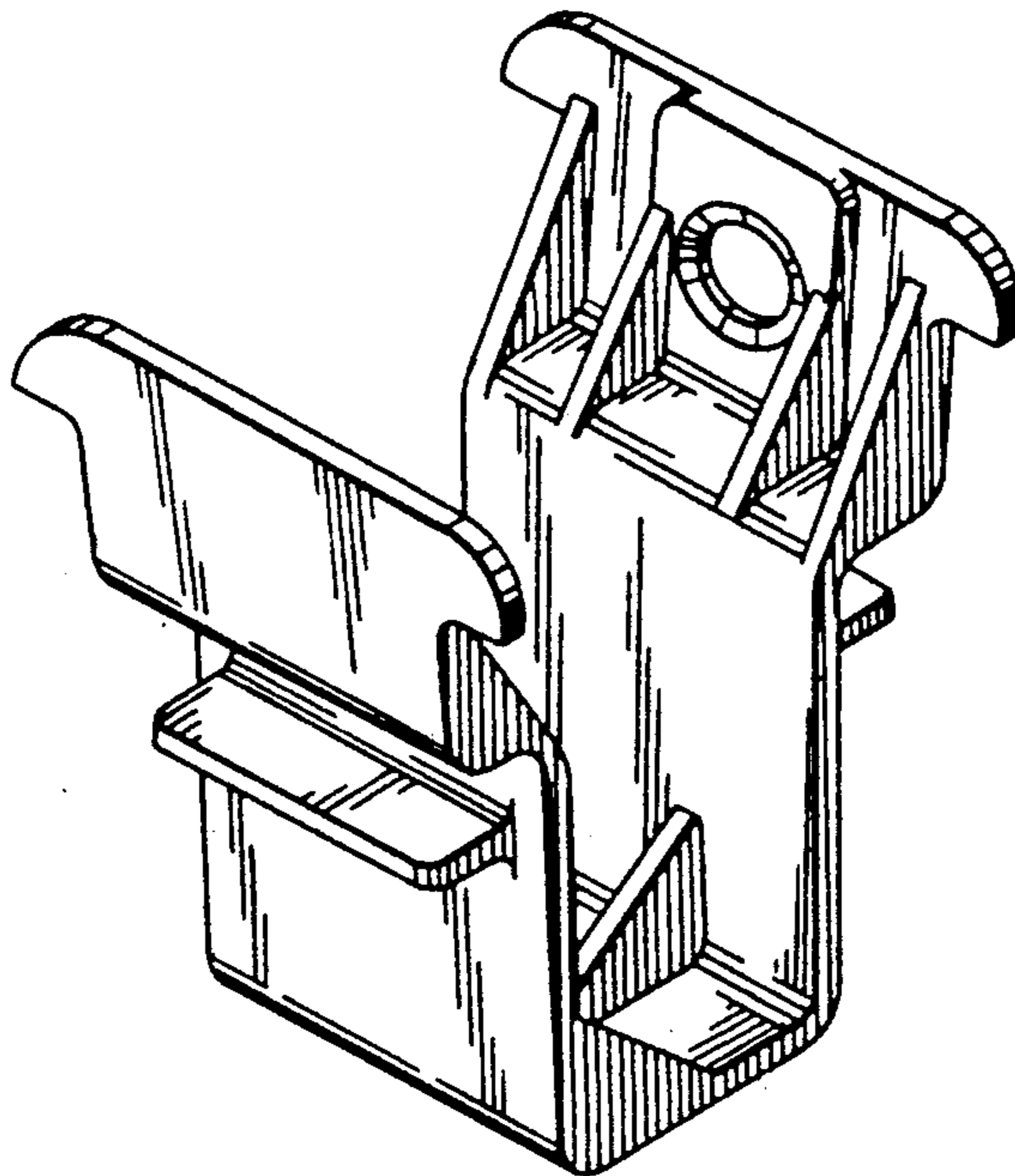

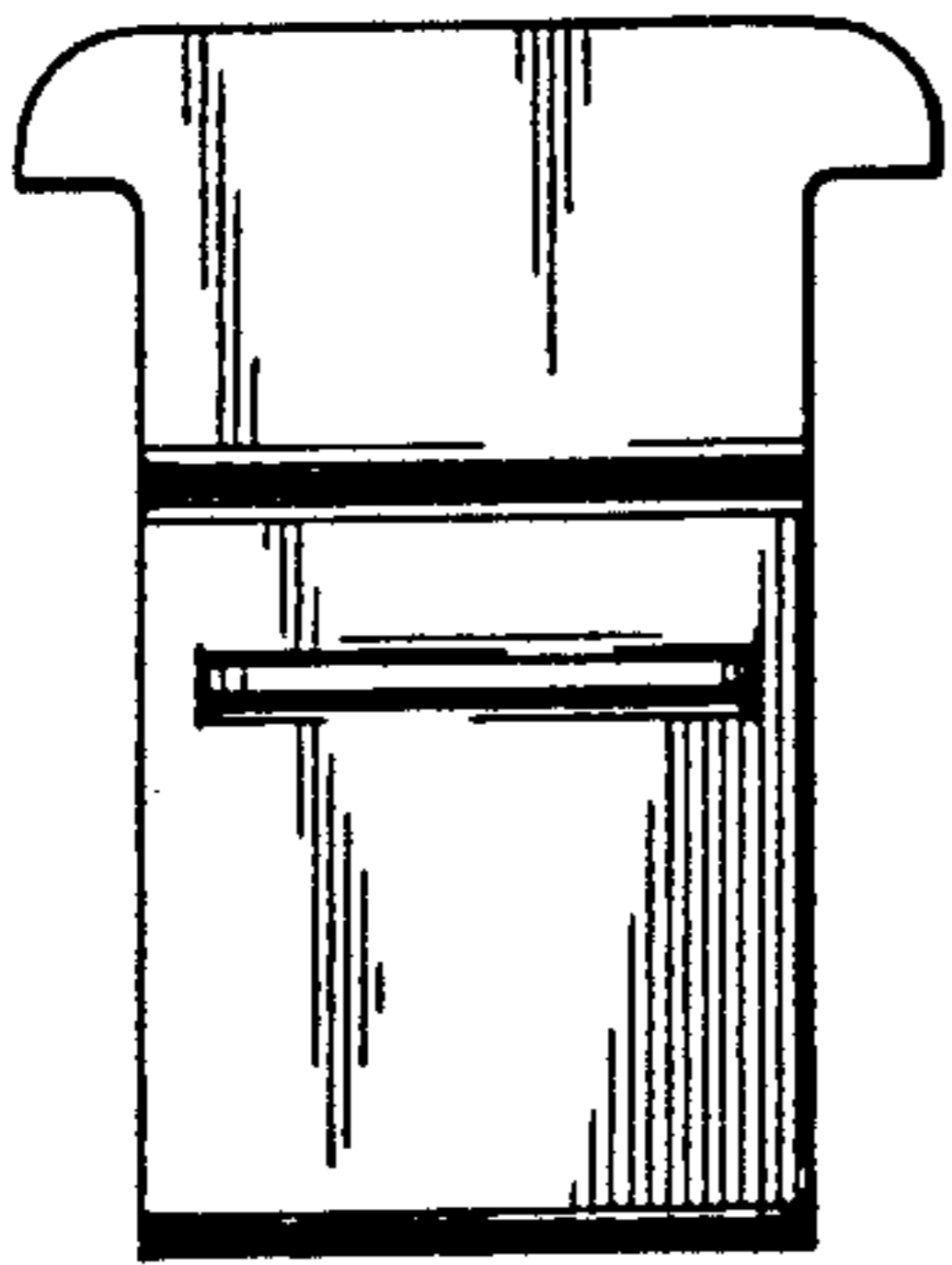

FIG. 2

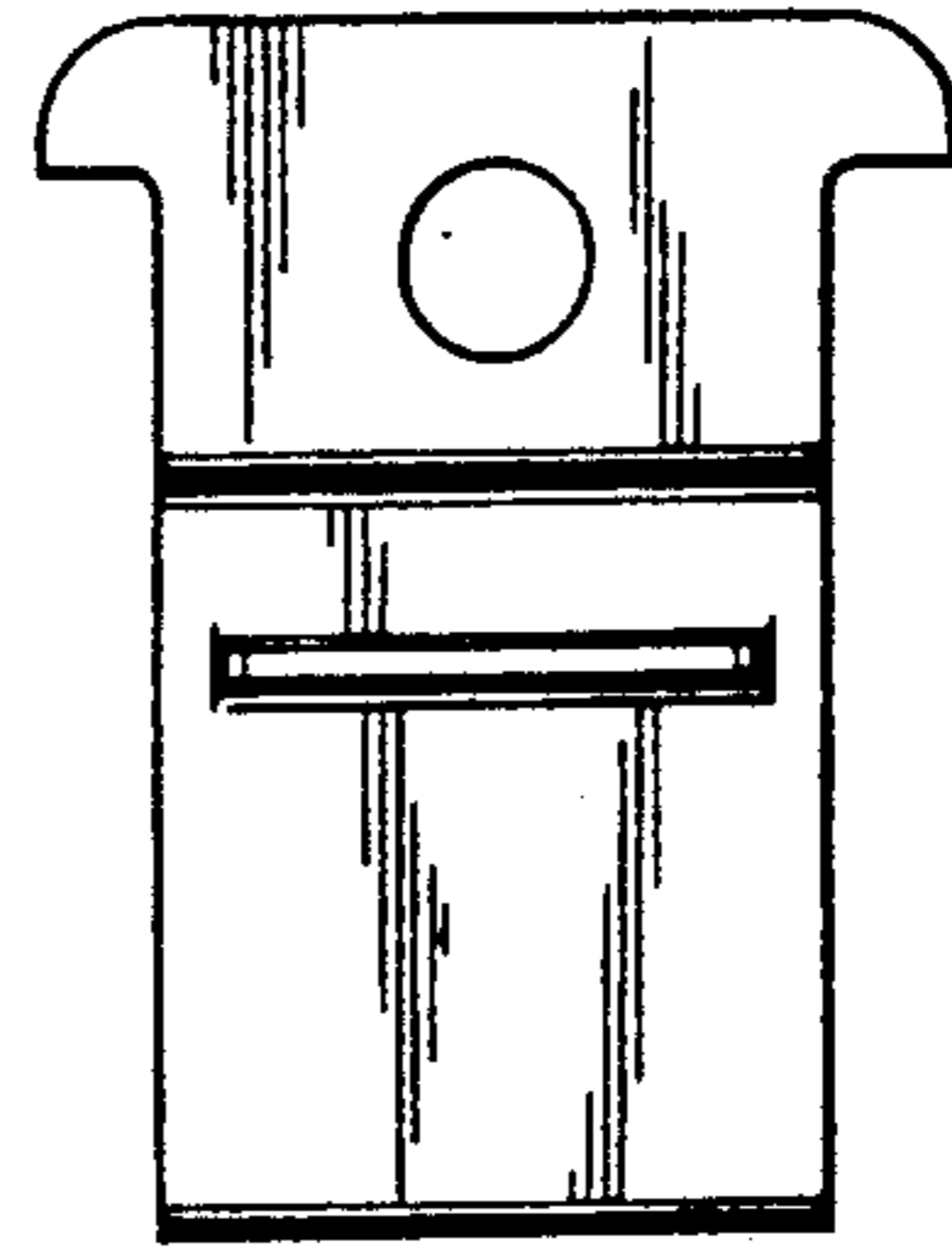

FIG. 3

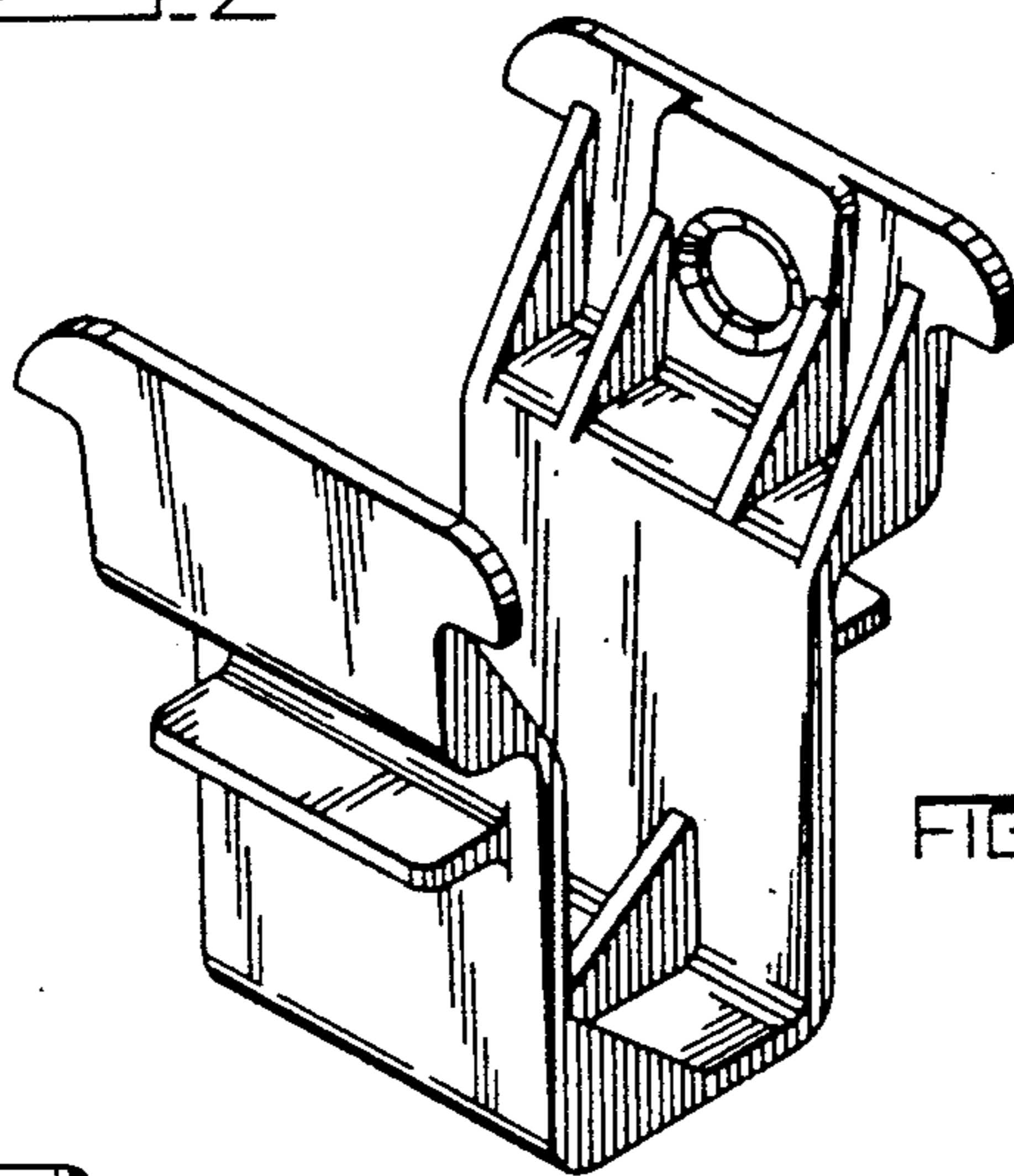

FIG. 1

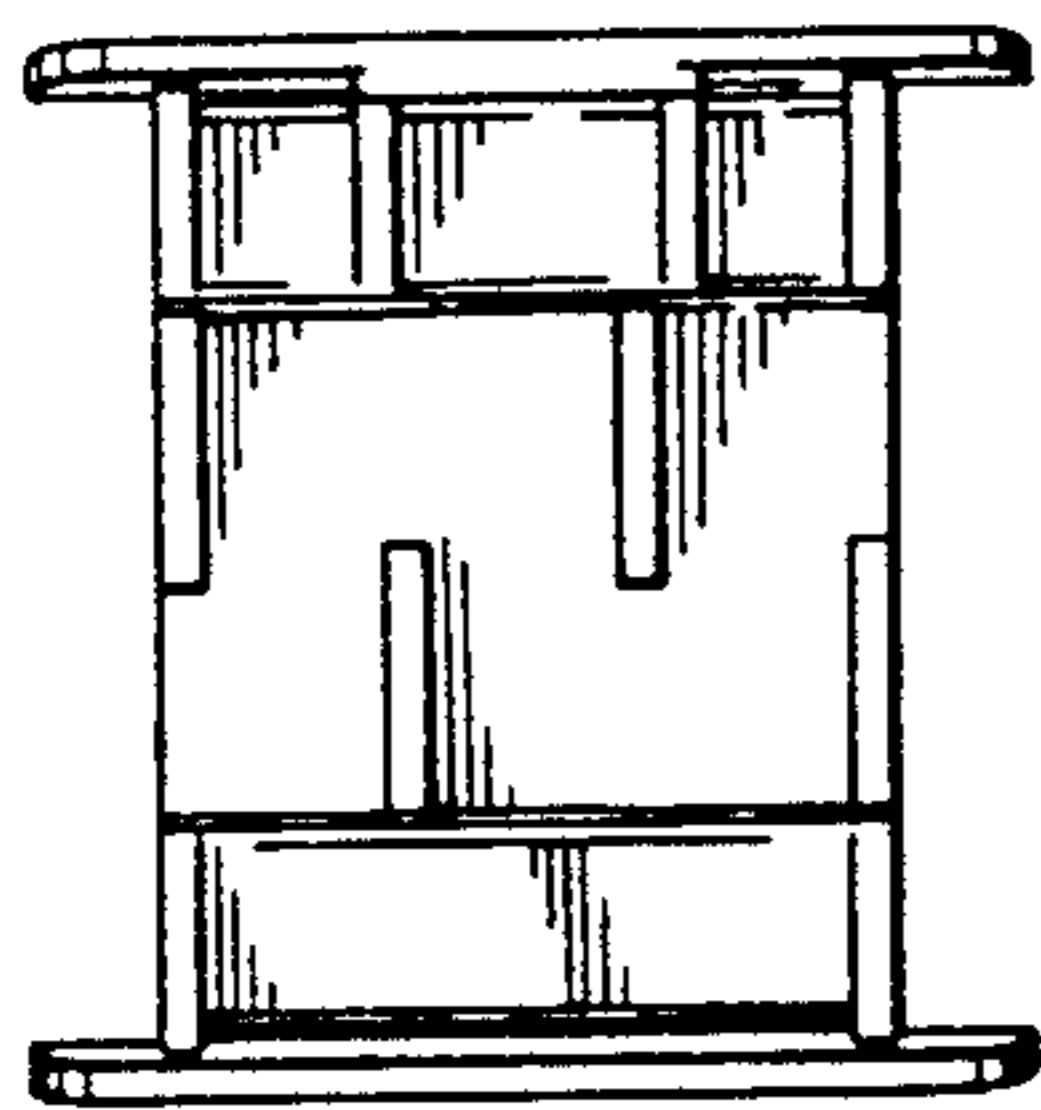

FIG. 4

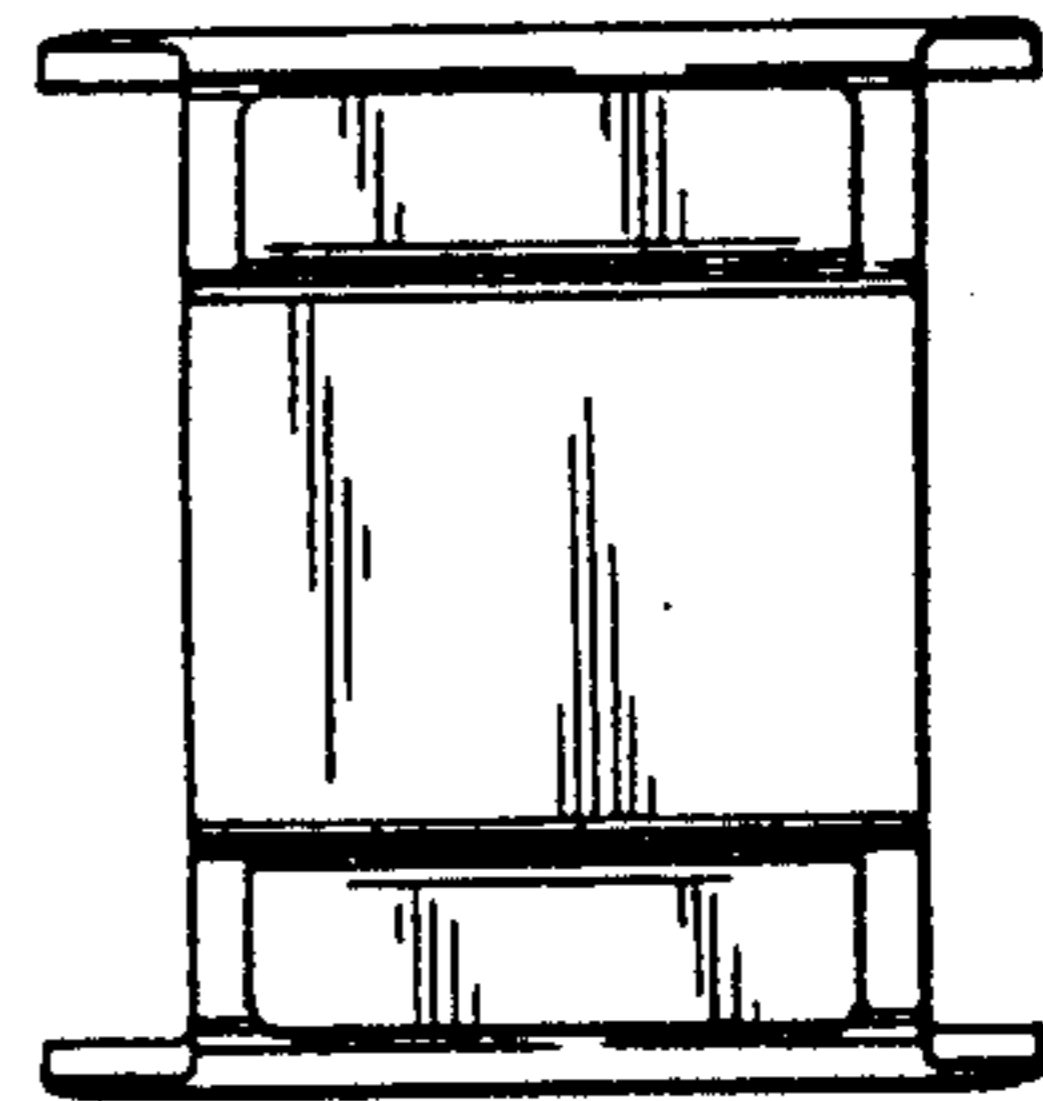

FIG. 5

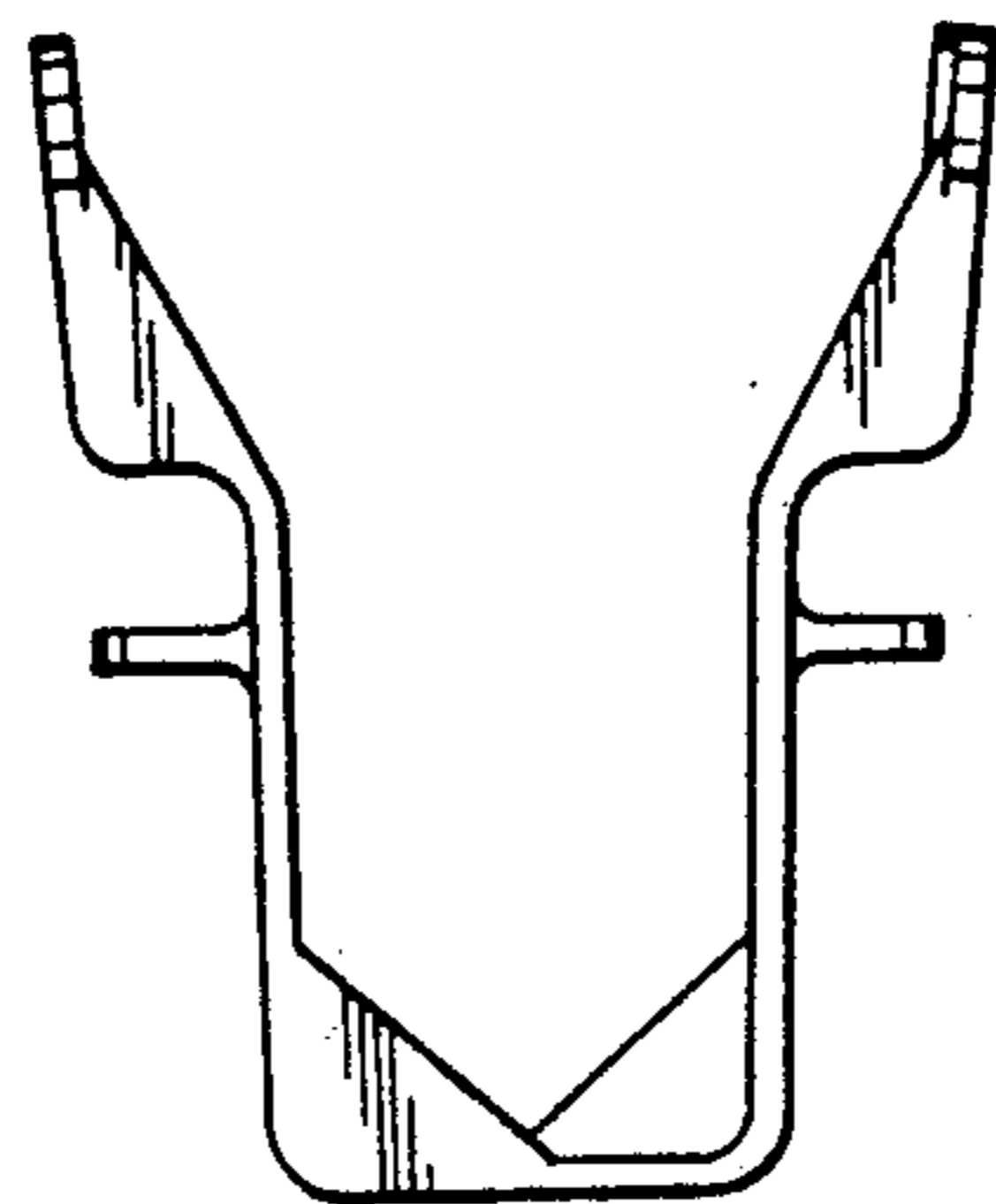

FIG. 6