

[54] **BRAKE PEDAL DEPRESSOR TOOL**

[76] **Inventor: William E. Hillock, Jr., 7653 Avon Pkwy., Danville, Ind. 46122**

[**] **Term: 14 Years**

[21] **Appl. No.: 267,513**

[22] **Filed: Nov. 4, 1988**

[52] **U.S. Cl. D8/71**

[58] **Field of Search D8/71; 74/532; 254/DIG. 4, DIG. 5, 133 R**

[56] **References Cited**

U.S. PATENT DOCUMENTS

1,558,854	10/1925	Falconer .	
1,707,113	6/1927	Christ	74/532 X
1,813,426	7/1931	Russell, Jr. et al. .	
2,138,911	12/1938	Evans et al. .	
2,523,850	7/1950	Digman .	
2,662,728	5/1951	Hanes et al. .	
2,755,684	7/1956	Russell	74/532 X
2,787,918	4/1957	Dow	74/532
2,844,235	7/1958	O'Connor	74/532 X
2,861,468	11/1958	Dow	74/532 X
2,866,356	12/1958	Elam	74/532
3,209,614	10/1965	Prescott	74/532
3,225,623	12/1965	Hyman	74/532

3,226,997	1/1966	Malloy	74/532 X
3,315,532	4/1967	Carnesecca, Jr. et al.	74/532
3,316,777	5/1967	Sain	74/532
3,329,041	7/1967	Moss	74/532
3,722,266	3/1973	Dunham .	
3,749,212	7/1973	Black	74/532 X
3,845,847	11/1974	Camp	74/532 X
3,910,135	10/1975	Phillips	74/532
4,432,432	2/1984	Martin .	

Primary Examiner—Bruce W. Dunkins
Assistant Examiner—Monica Hannon
Attorney, Agent, or Firm—Woodard, Emhardt, Naughton, Moriarty & McNett

[57] **CLAIM**

The ornamental design for a brake pedal depressor tool, as shown and described.

DESCRIPTION

FIG. 1 is a front elevational view of a brake pedal depressor tool showing my new design; FIG. 2 is a top plan view thereof; FIG. 3 is a bottom plan view thereof; FIG. 4 is a rear elevational view thereof; FIG. 5 is a left elevational view thereof; FIG. 6 is a right elevational view thereof; and FIG. 7 is a second embodiment of FIG. 1 with the lever handle in an extended position.

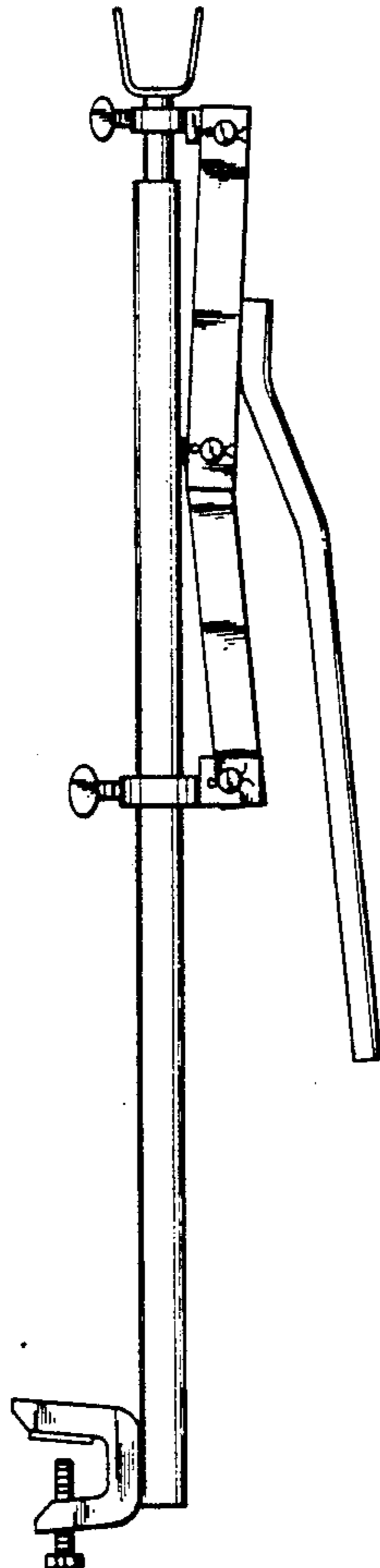

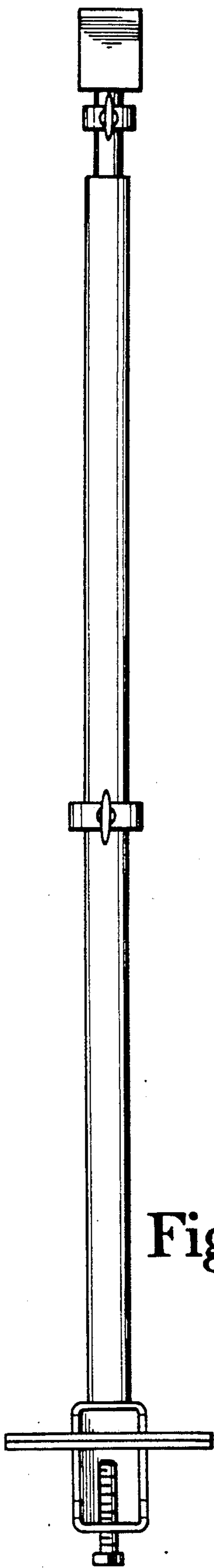

Fig.3

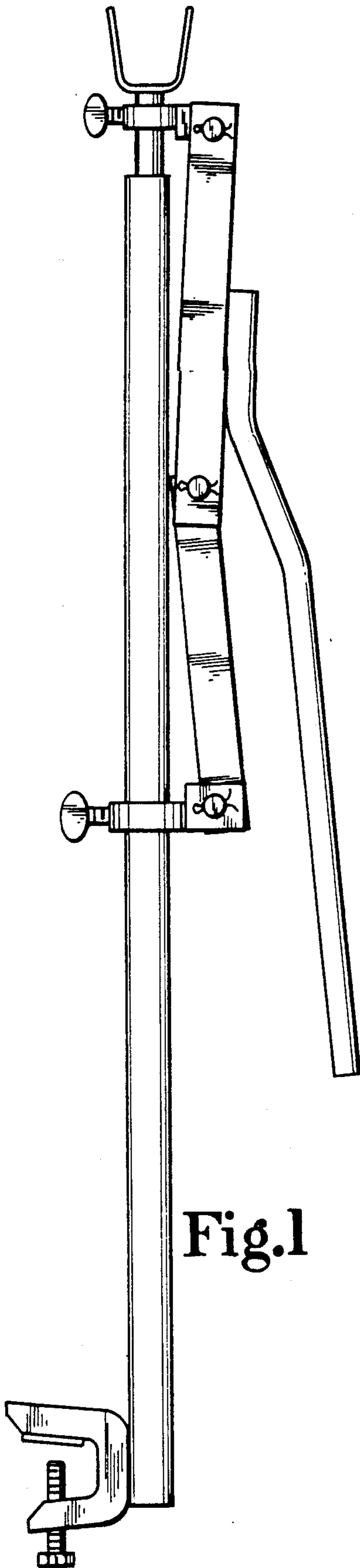

Fig.1

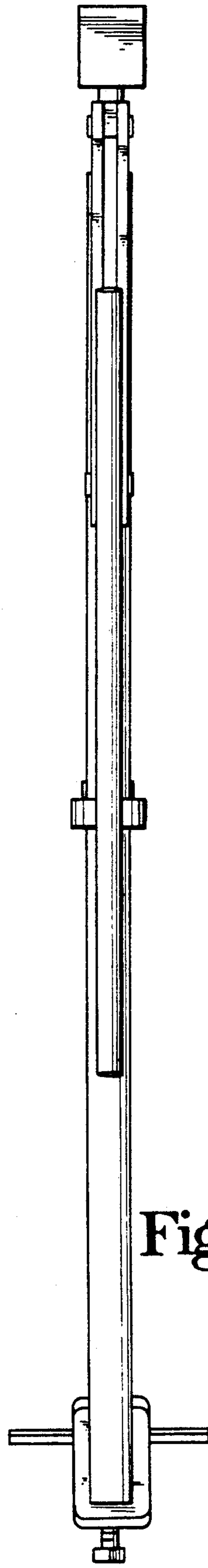

Fig.2

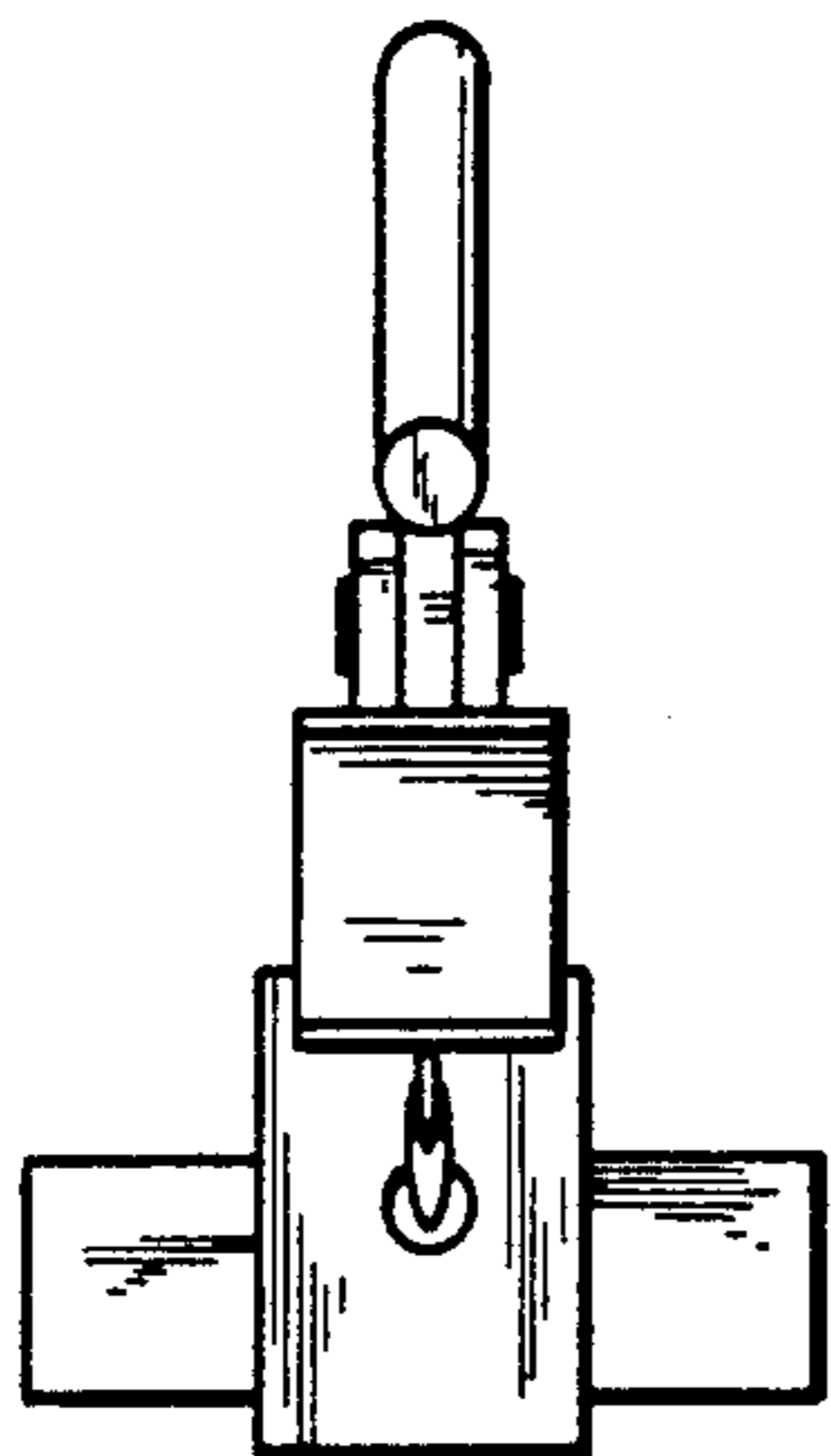

Fig. 5

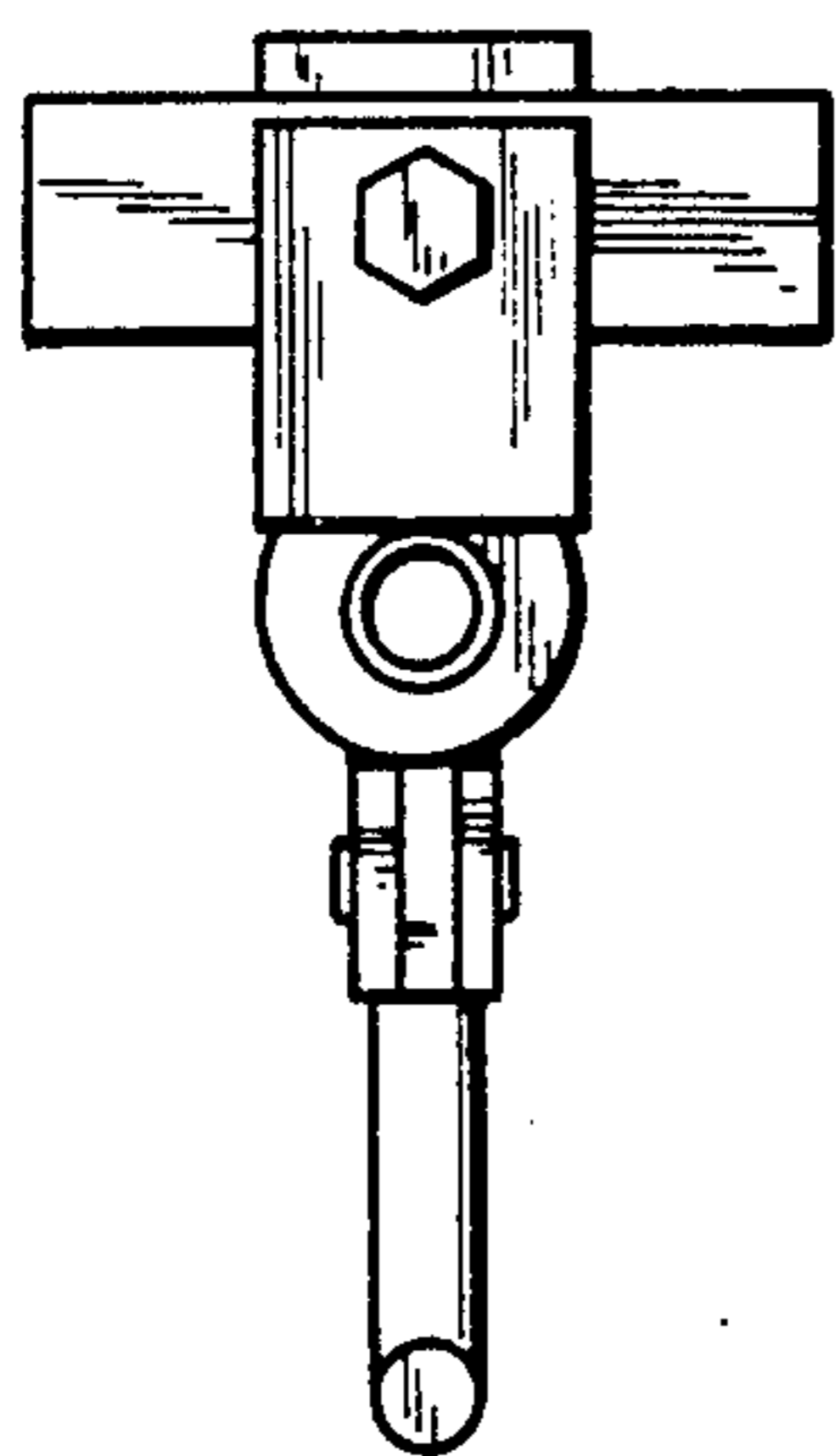

Fig. 6

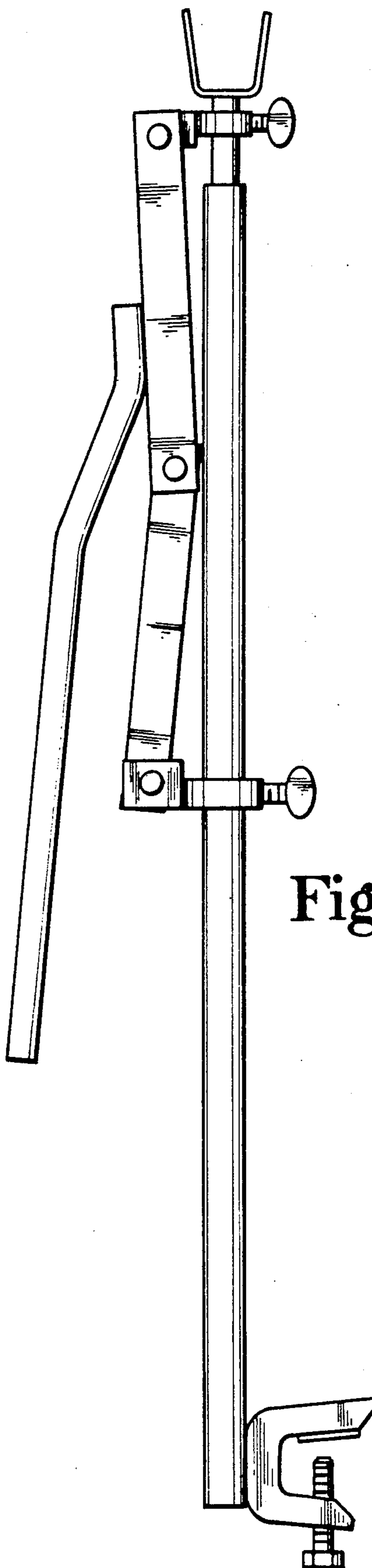

Fig. 4

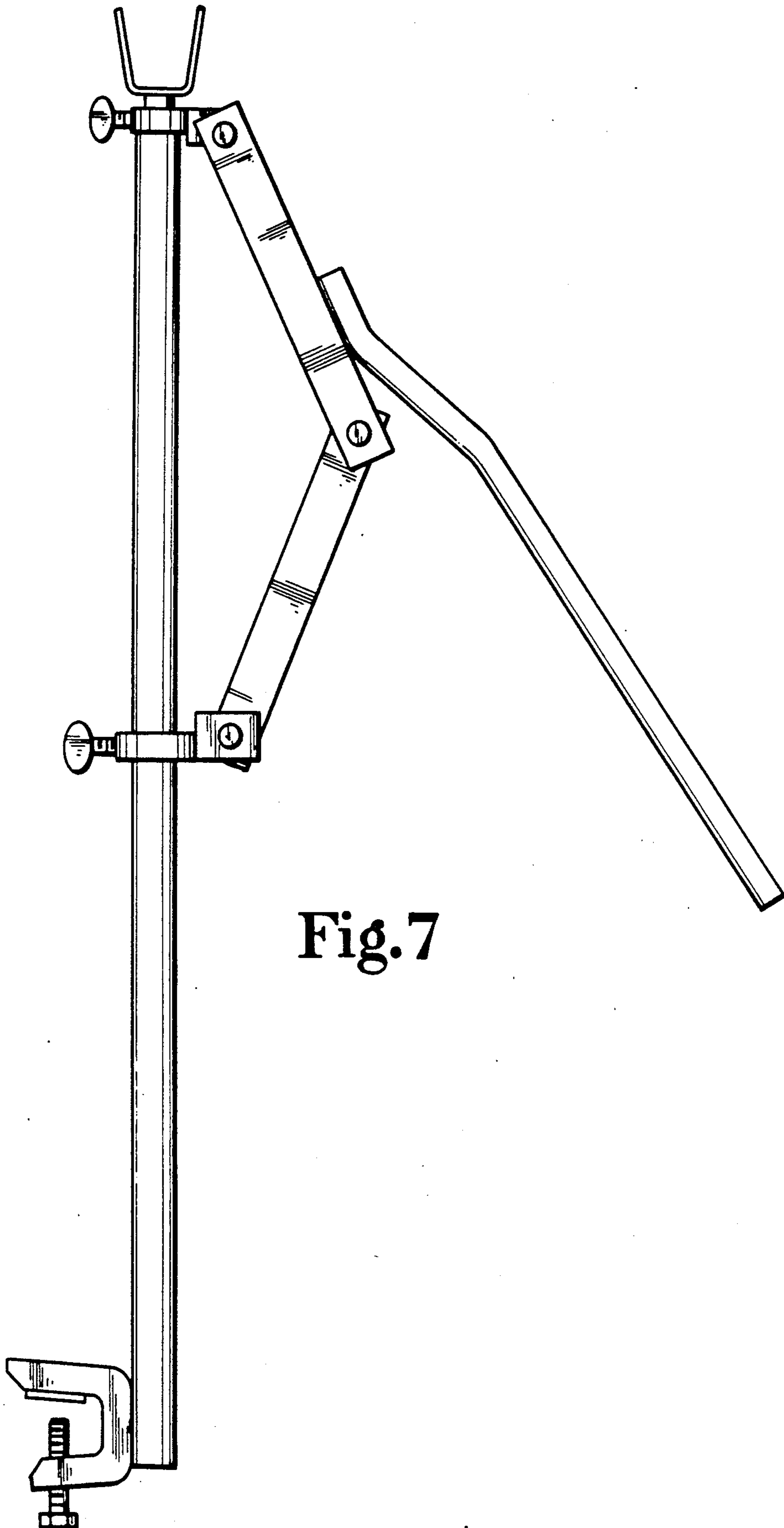

Fig. 7