

# United States Patent [19]

Yamamoto

[11] Patent Number: **Des. 319,510**

[45] Date of Patent: **\*\* Aug. 27, 1991**

[54] REAR COMBINATION LAMP FOR CAR

[75] Inventor: **Hiroshi Yamamoto**, Kanagawa, Japan

[73] Assignee: **Mazda Motor Corporation**, Hiroshima, Japan

[\*\*] Term: **14 Years**

[21] Appl. No.: **188,790**

[22] Filed: **Apr. 28, 1988**

[52] U.S. Cl. .... **D26/35**

[58] Field of Search ..... **D26/28-36, D26/121, 122, 120; 362/61, 80, 80.1, 80.2, 82, 83, 83.2, 83.3, 326, 329, 335, 337, 339, 340, 362**

[56] **References Cited**

**U.S. PATENT DOCUMENTS**

D. 285,122 8/1986 Fujita ..... D26/35  
D. 293,134 12/1987 Mori ..... D26/35

D. 293,936 1/1988 Kawaoka ..... D26/28  
D. 302,320 7/1989 Toyota ..... D26/28  
4,532,578 7/1985 Gaden et al. .... 362/80 X

*Primary Examiner*—Susan J. Lucas  
*Attorney, Agent, or Firm*—Fleit, Jacobson, Cohn, Price, Holman & Stern

[57] **CLAIM**

The ornamental design for rear combination lamp for car, as shown and described.

**DESCRIPTION**

FIG. 1 is a front perspective view of a rear combination lamp for car embodying my new design; FIG. 2 is a front elevational view thereof; FIG. 3 is a right side view thereof; FIG. 4 is a left side view thereof; FIG. 5 is a rear elevational view thereof; FIG. 6 is a top plan view thereof; and FIG. 7 is a bottom plan view thereof.

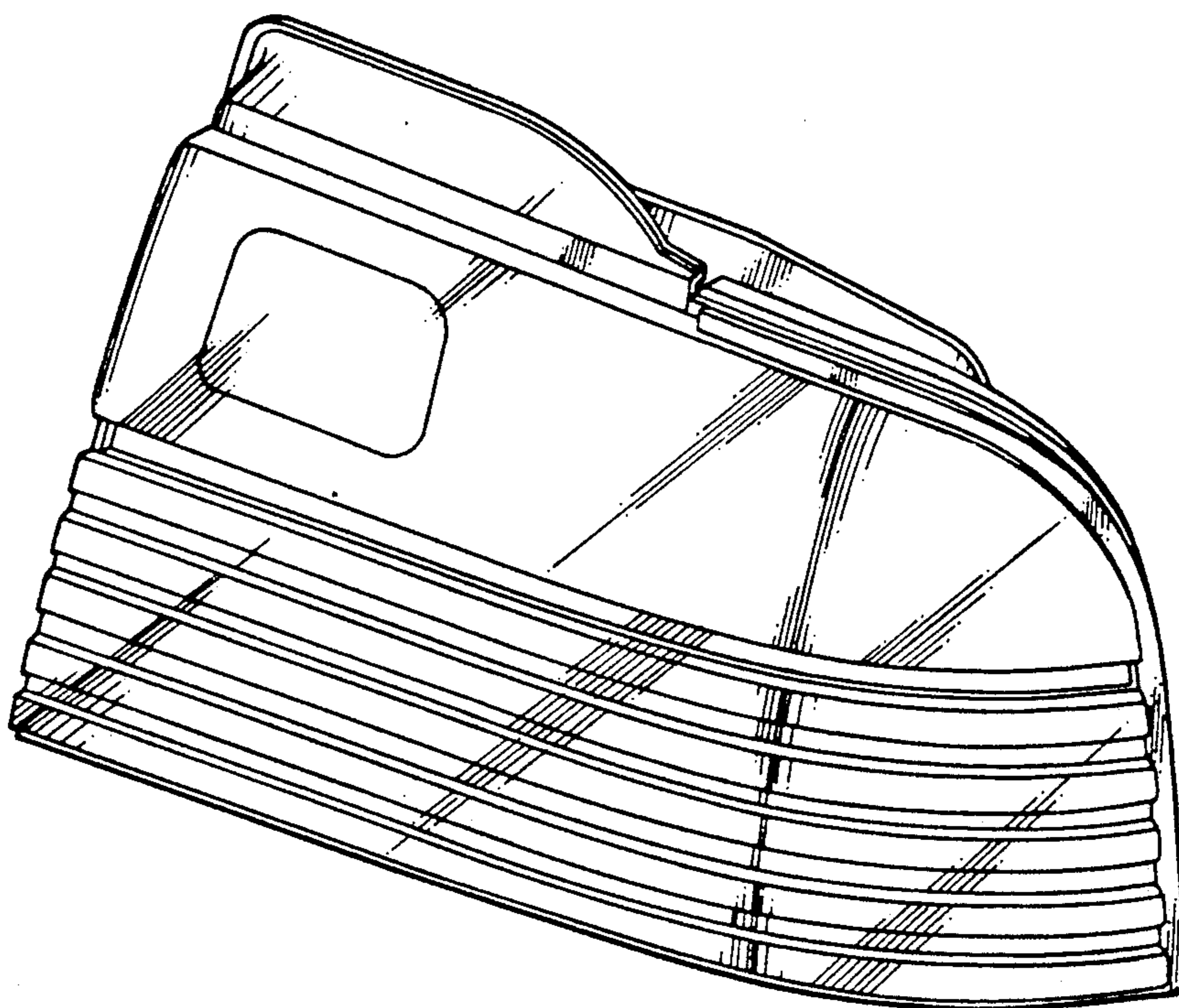

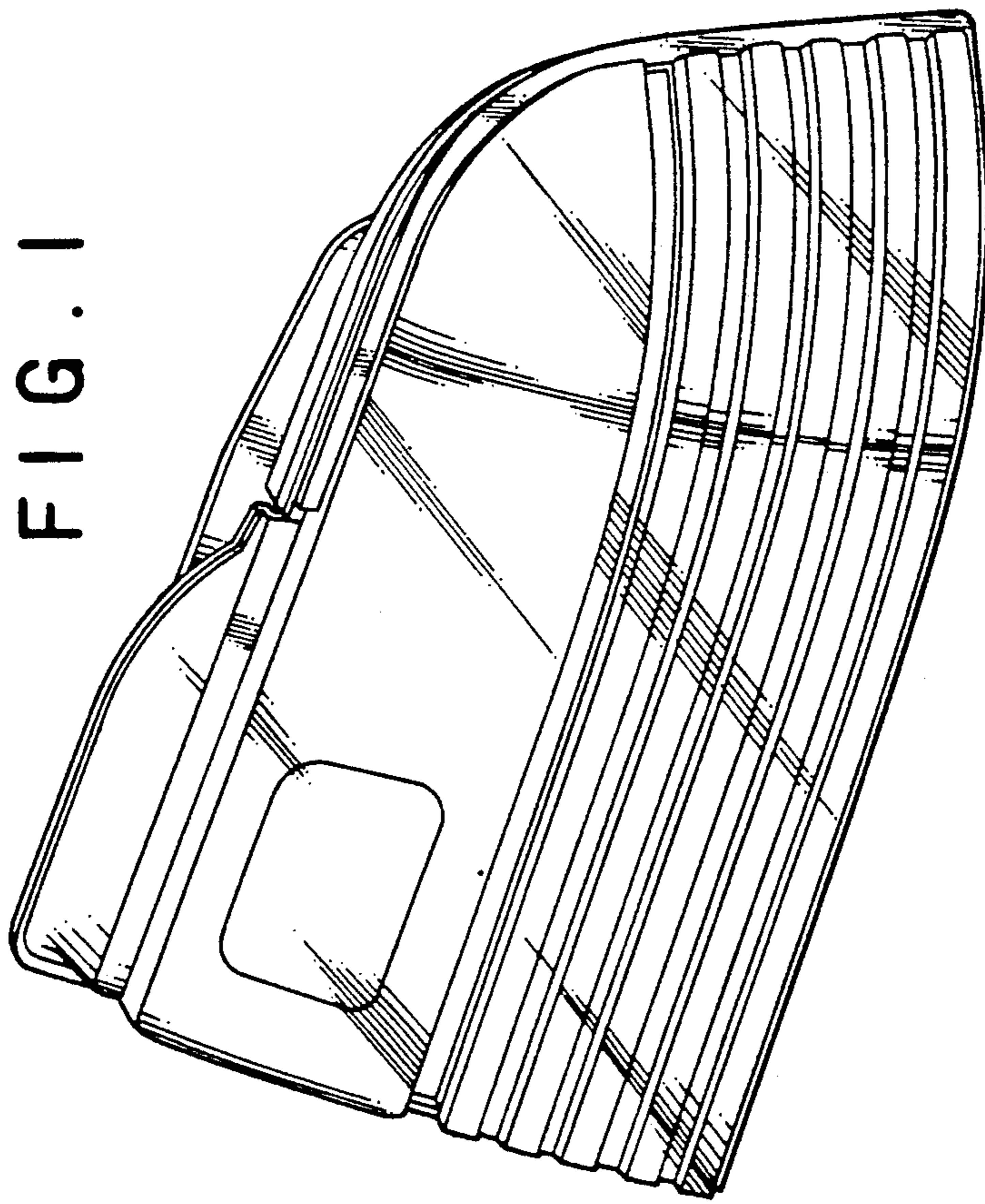

FIG. 1

FIG. 3

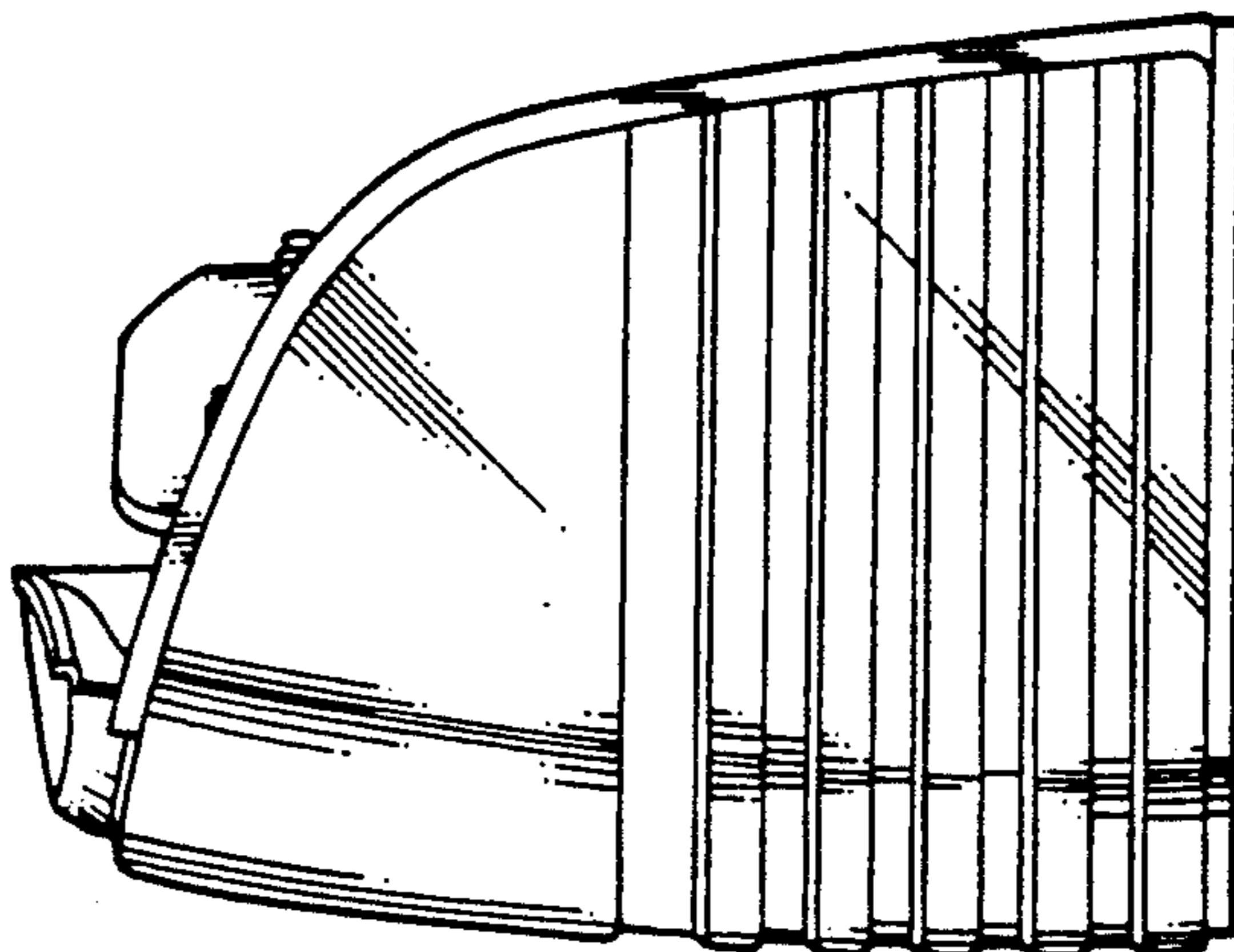

FIG. 2

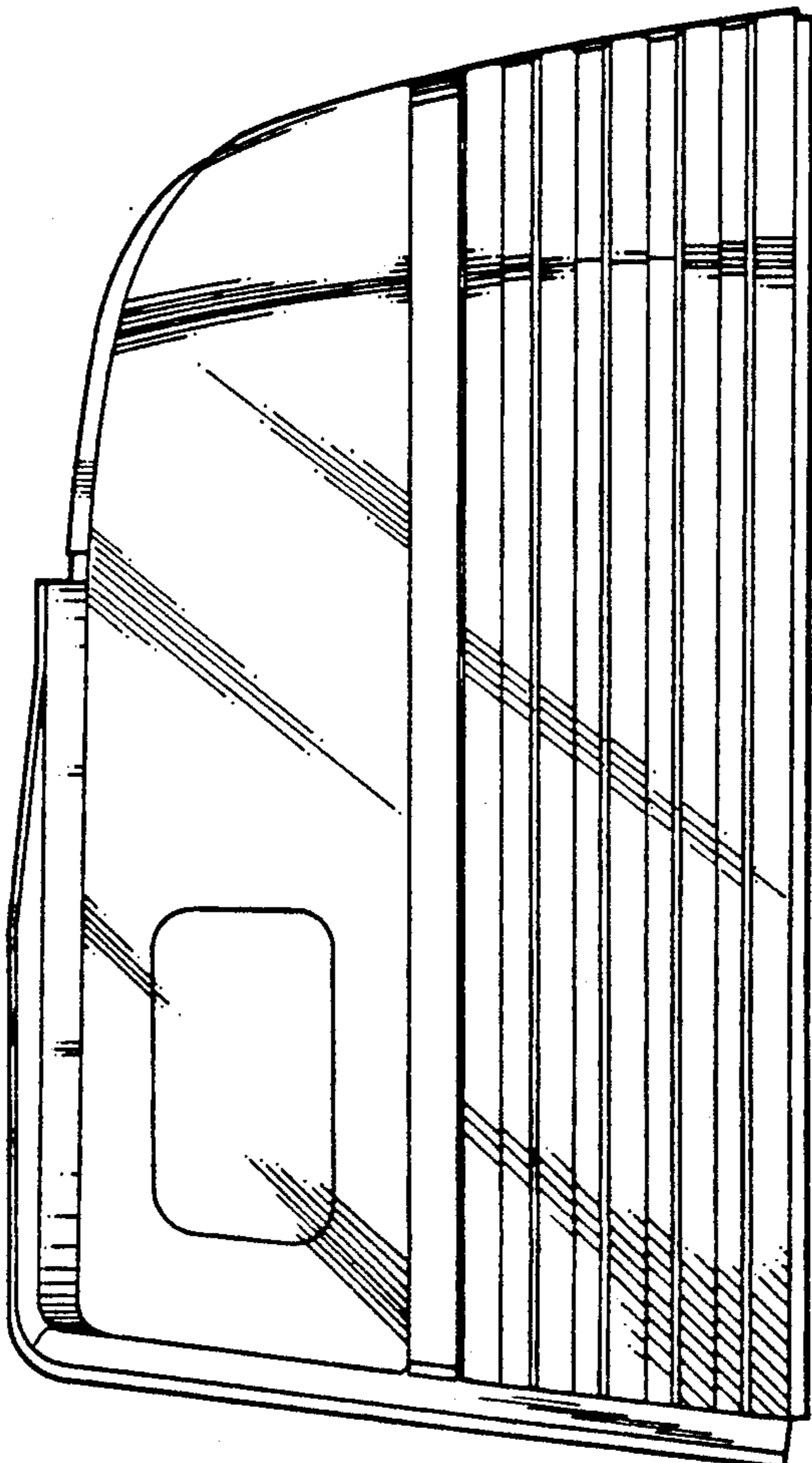

FIG. 5

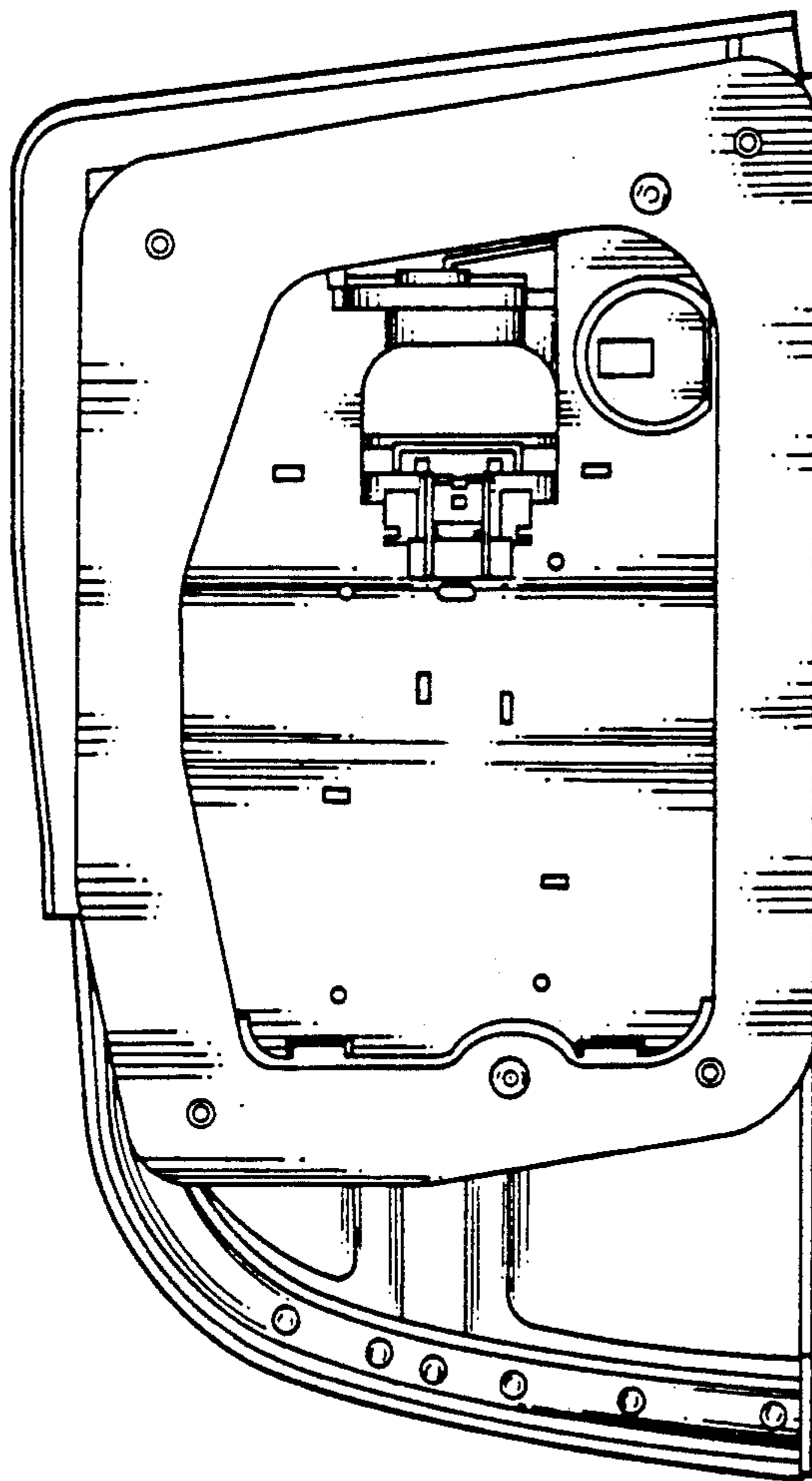

FIG. 4

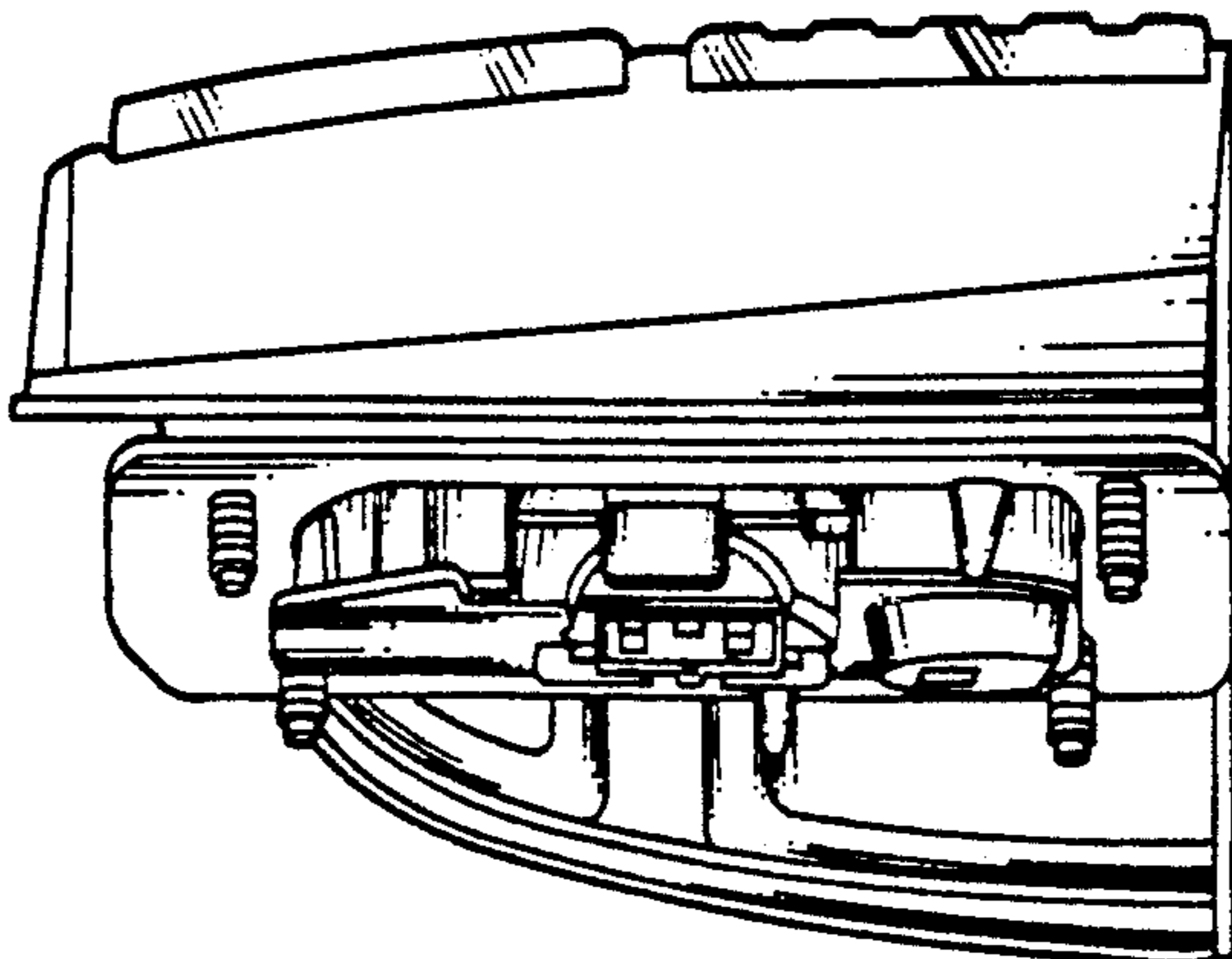



FIG. 6

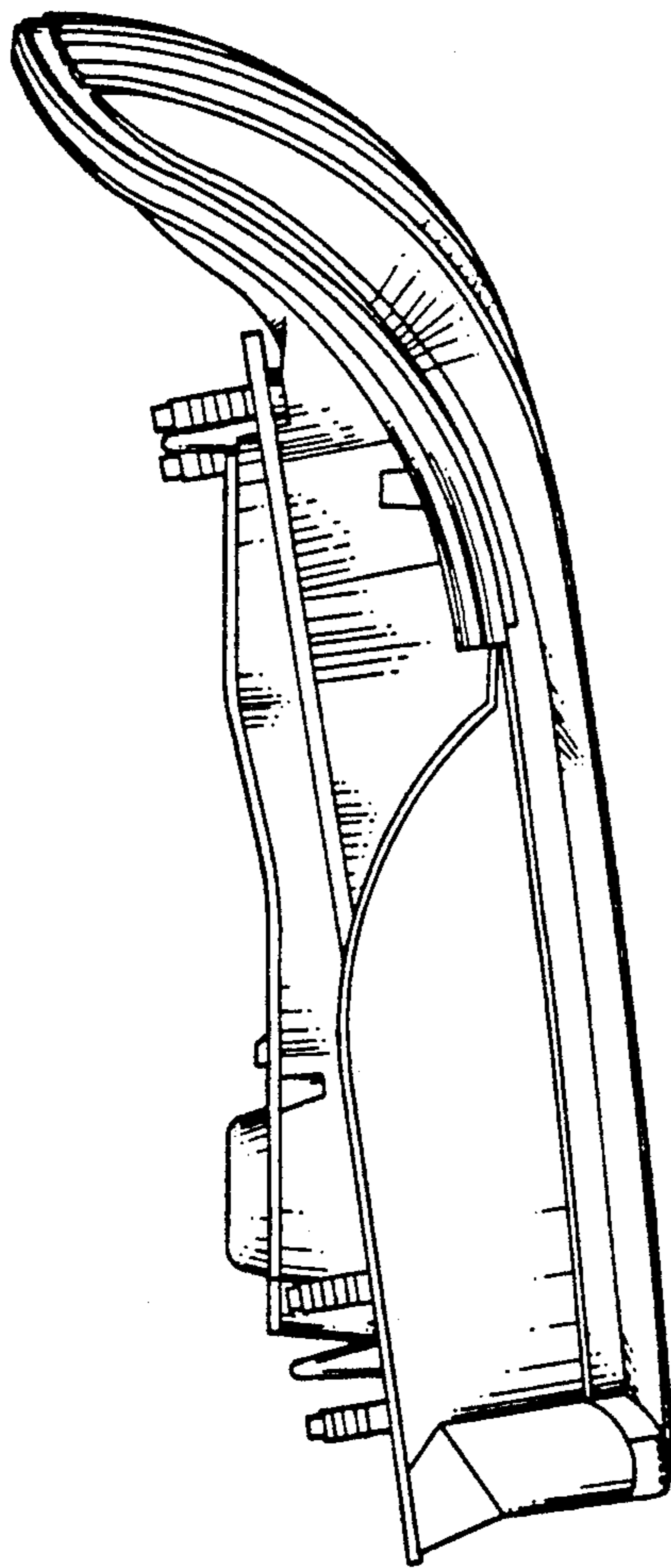

FIG. 7

