

[54] PICK-UP UNIT FOR ELECTRONIC GUITARS

OTHER PUBLICATIONS

[76] Inventor: C. Leo Fender, 1510 Dana Pl., Fullerton, Calif. 92635

Sweet's 1969, Fastening File, Shakeproof Catalog, p. 18.

[**] Term: 14 Years

Primary Examiner—Bernard Ansher
Assistant Examiner—Adir Aronovich
Attorney, Agent, or Firm—Spensley Horn Jubas & Lubitz

[21] Appl. No.: 194,007

[57] CLAIM

[22] Filed: May 13, 1988

The ornamental design for a pick-up unit for electronic guitar, as shown and nd described.

[52] U.S. Cl. D17/20

[58] Field of Search D17/14, 15, 18, 19, D17/20, 21; 84/723, 724, 725-728, 729-733

DESCRIPTION

[56] References Cited

U.S. PATENT DOCUMENTS

D. 287,602	1/1987	Smith et al.	D17/21
3,541,219	11/1970	Abair	84/727
4,133,243	1/1979	DiMarzio	84/727
4,220,069	9/1980	Fender	84/726
4,364,295	12/1982	Stich	84/726
4,535,668	8/1985	Schaller	84/727

FIG. 1 is a perspective view of a pick-up unit for electronic guitars showing my new design;
FIG. 2 is a top plan view thereof;
FIG. 3 is a side elevational view thereof;
FIG. 4 is a front elevational view thereof;
FIG. 5 is a plan view of the underside thereof; and
FIG. 6 is a perspective view thereof.

The broken line showing of an electronic guitar is for illustrative purposes only and forms no part of the claimed design.

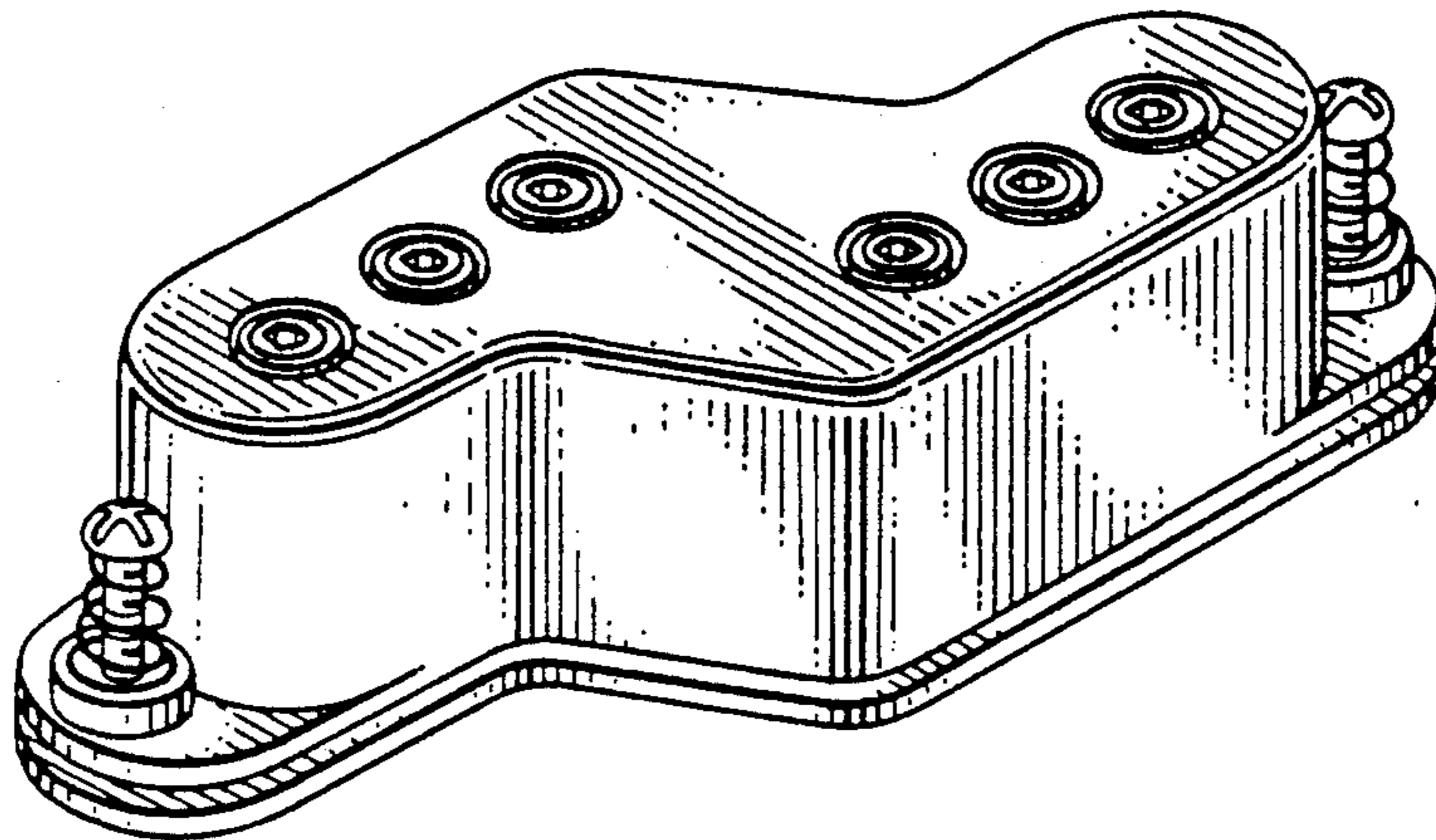

Fig. 1

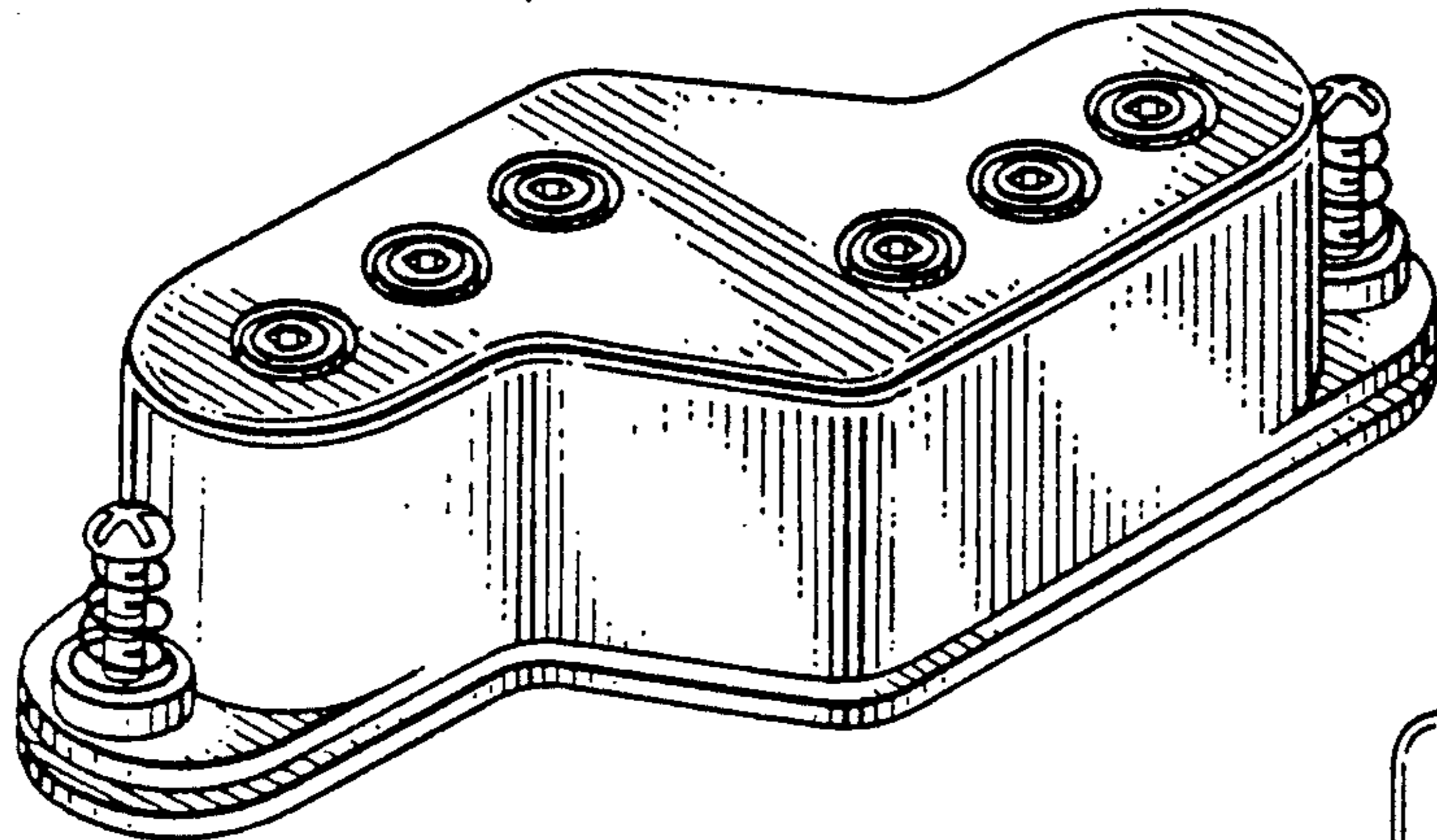

Fig. 3

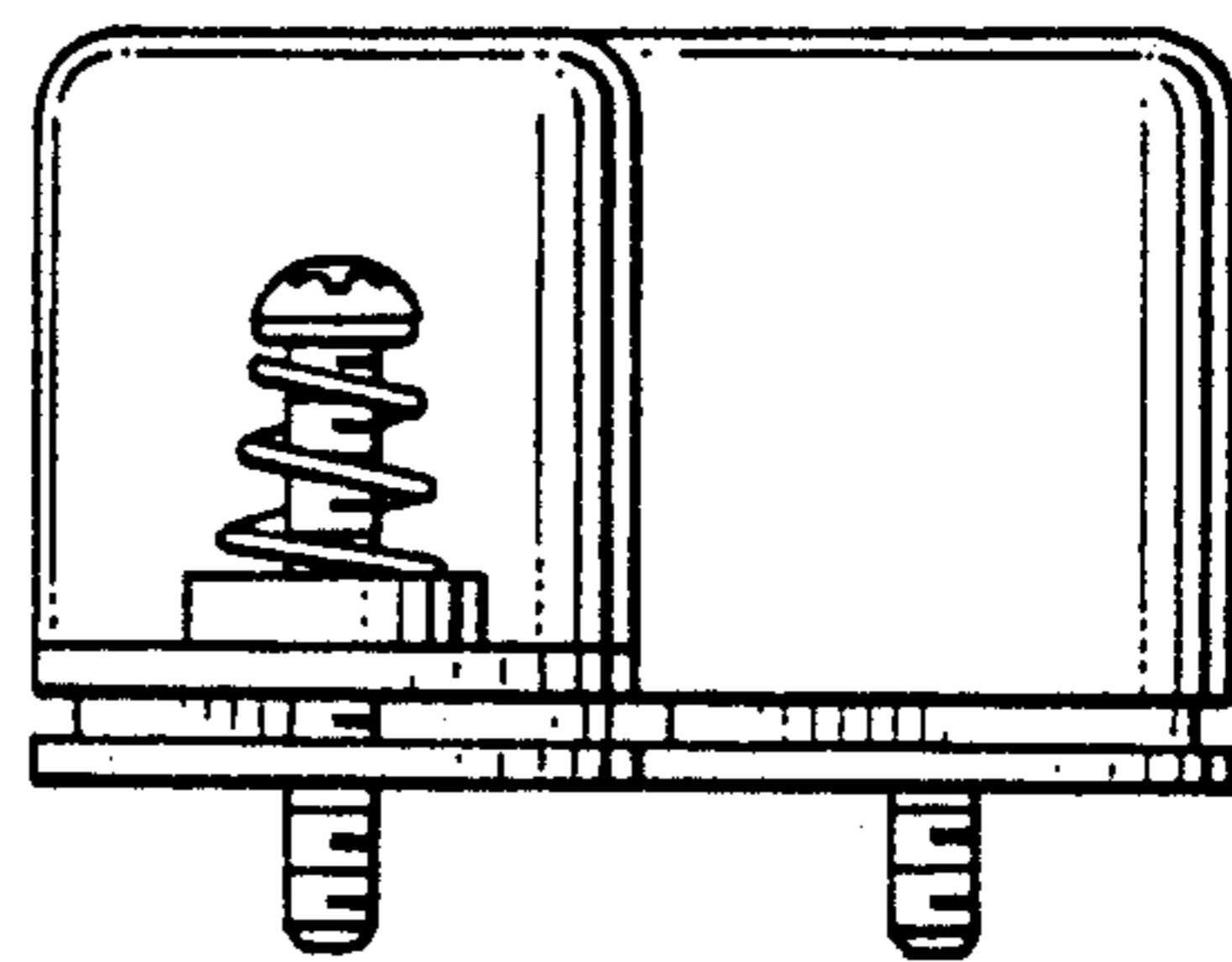

Fig. 2

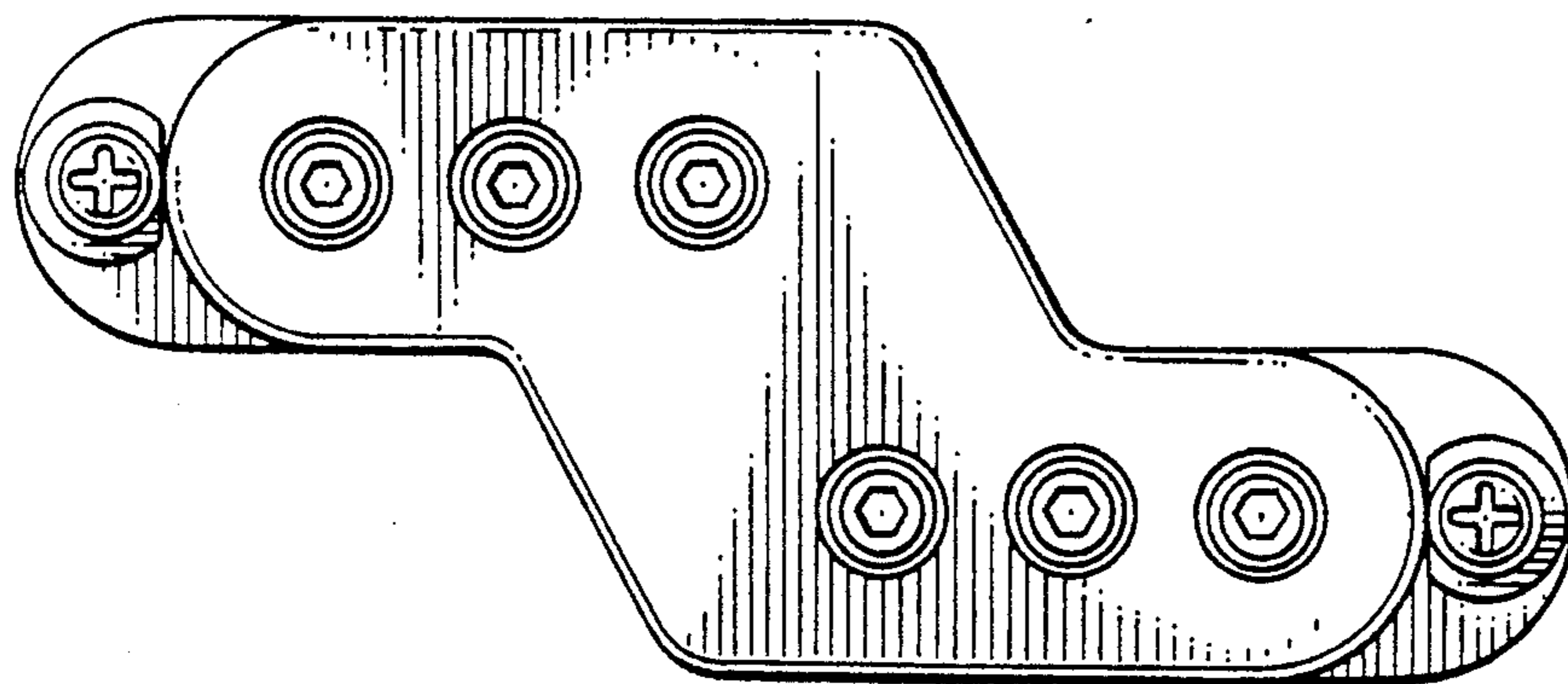

Fig. 4

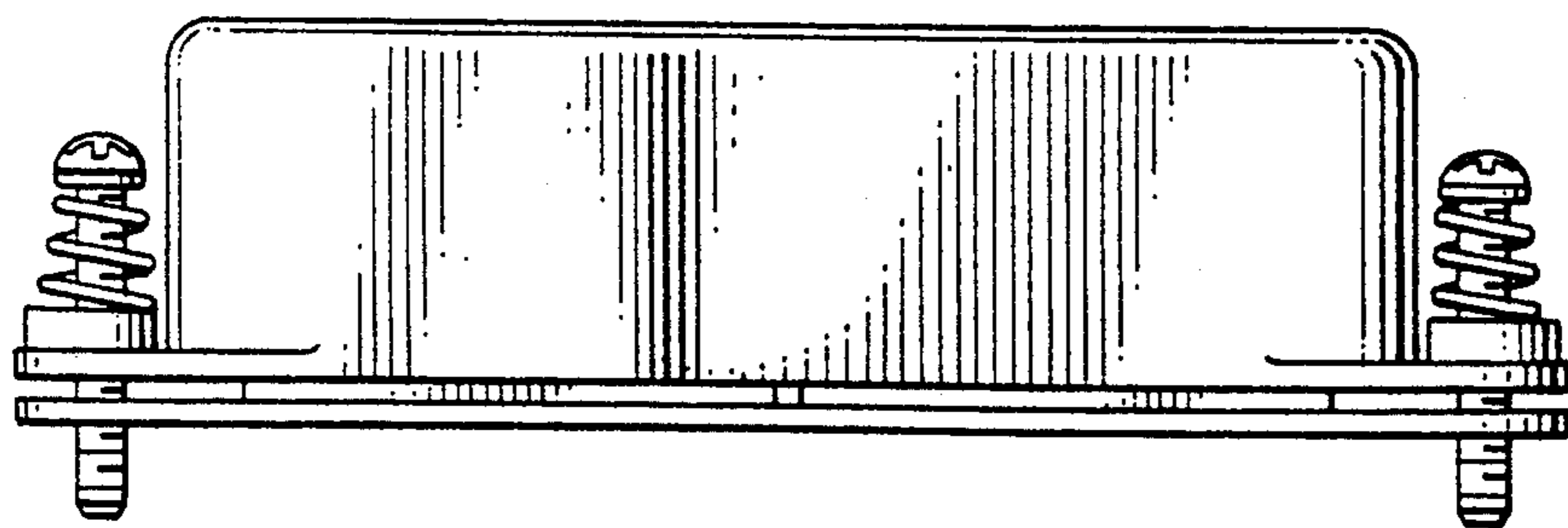

Fig. 5

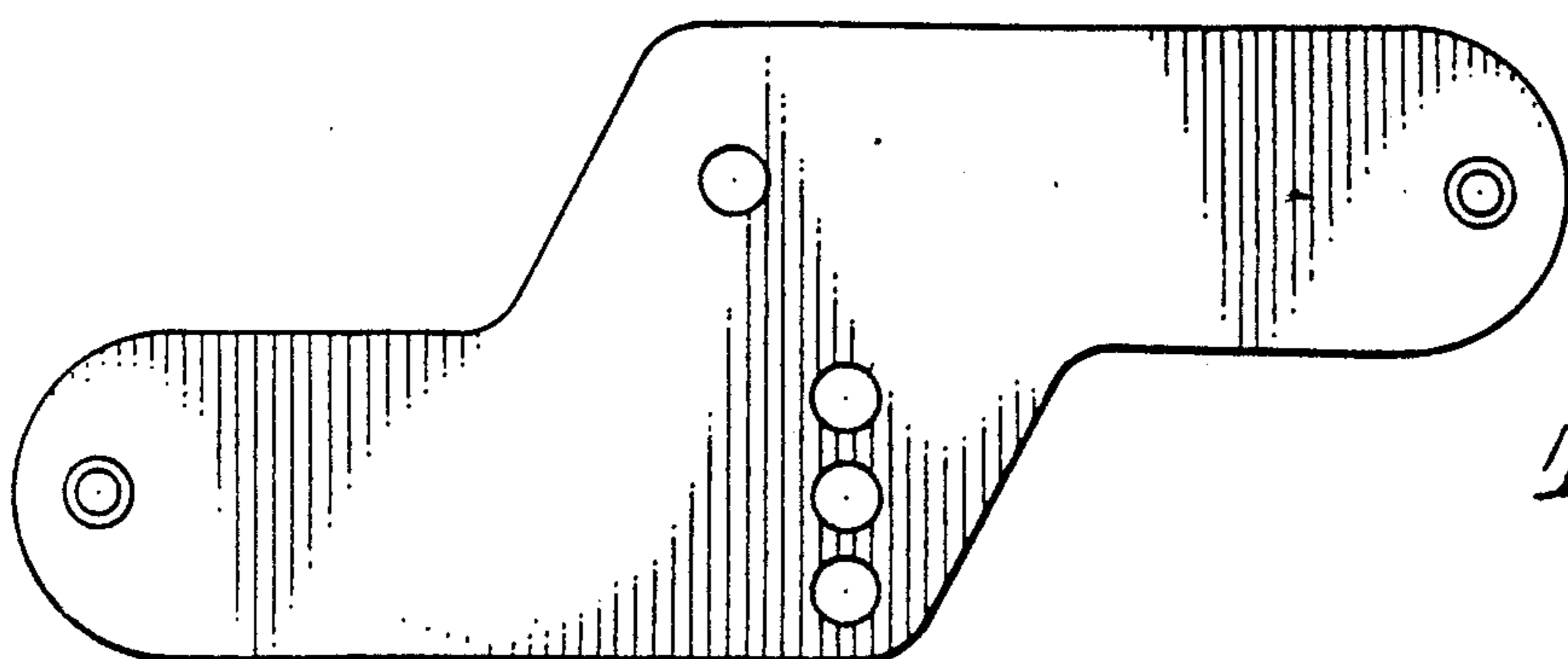

FIG. 6

