

[54] TRUCK

[75] Inventors: Hiromu Wada; Yukio Hirano; Naoyuki Akashi; Tohru Takagi, all of Fujisawa, Japan

[73] Assignee: Isuzu Motors Limited, Tokyo, Japan

[**] Term: 14 Years

[21] Appl. No.: 324,350

[22] Filed: Mar. 6, 1989

[30] Foreign Application Priority Data

Sep. 26, 1988 [JP] Japan 63-37410
[52] U.S. Cl. D12/96; D12/98
[58] Field of Search D12/96, 98, 156; 296/183, 185, 100

[56] References Cited

U.S. PATENT DOCUMENTS

D. 281,487 11/1985 Chapman D12/156
D. 294,242 2/1988 O'Neill D12/156
D. 313,379 1/1991 Machida et al. D12/98

OTHER PUBLICATIONS

Road & Track, 2/78, p. 112, Truck in Box 5, lower center of page.

Motor Trend, 1/88, p. 18, Range Rover, top of page.

Primary Examiner—James M. Gandy
Attorney, Agent, or Firm—Bradford E. Kile

[57] CLAIM

The ornamental design for a truck, as shown and described.

DESCRIPTION

FIG. 1 is a top, front and right side perspective view of a truck showing our new design;
FIG. 2 is a top, rear and right side perspective view thereof;
FIG. 3 is a front elevation view thereof;
FIG. 4 is a rear elevation view thereof;
FIG. 5 is a top plan view thereof;
FIG. 6 is a bottom plan view thereof;
FIG. 7 is a right side elevation view thereof; and
FIG. 8 is a left side elevation view thereof.

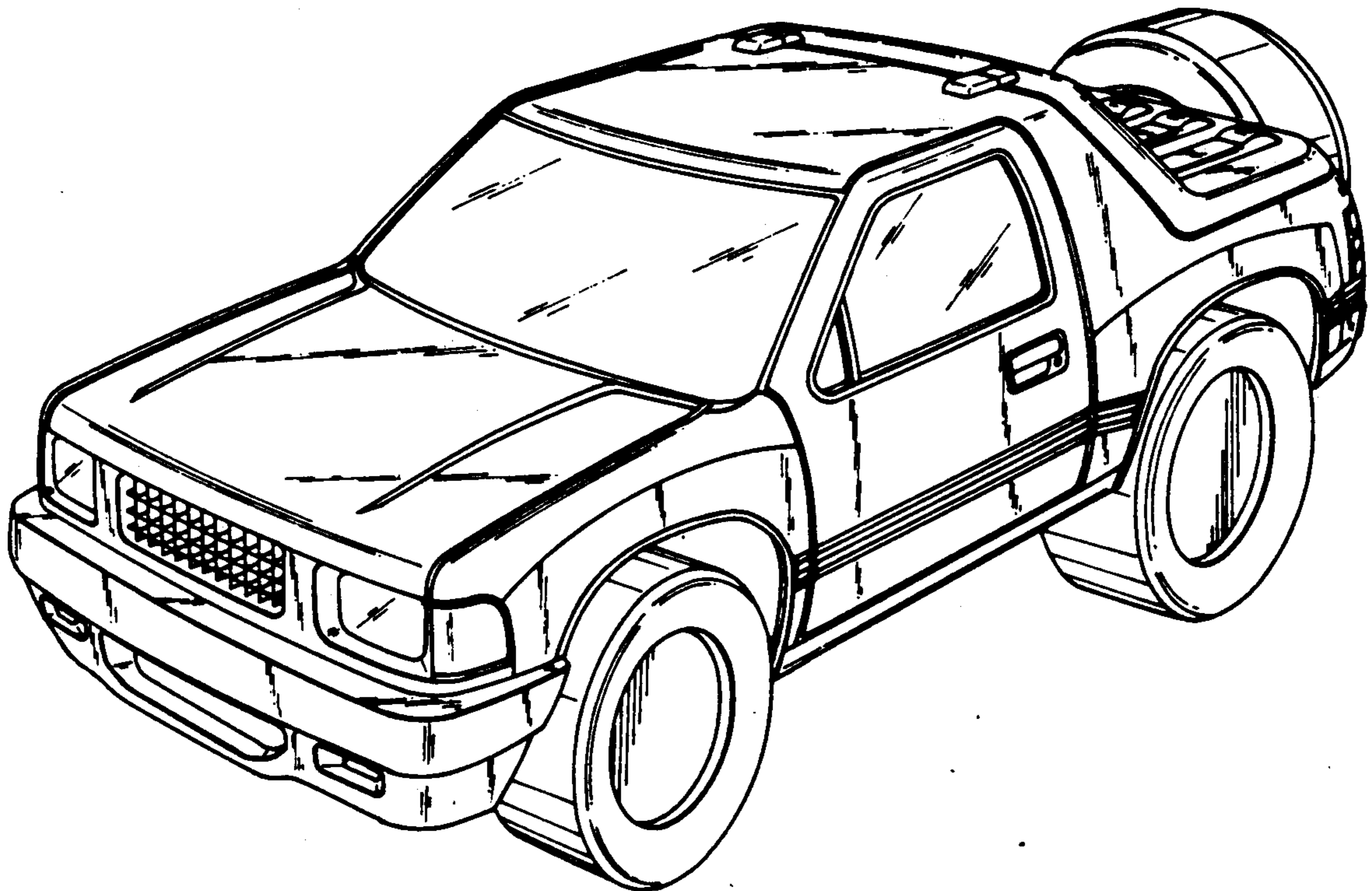

FIG. 1

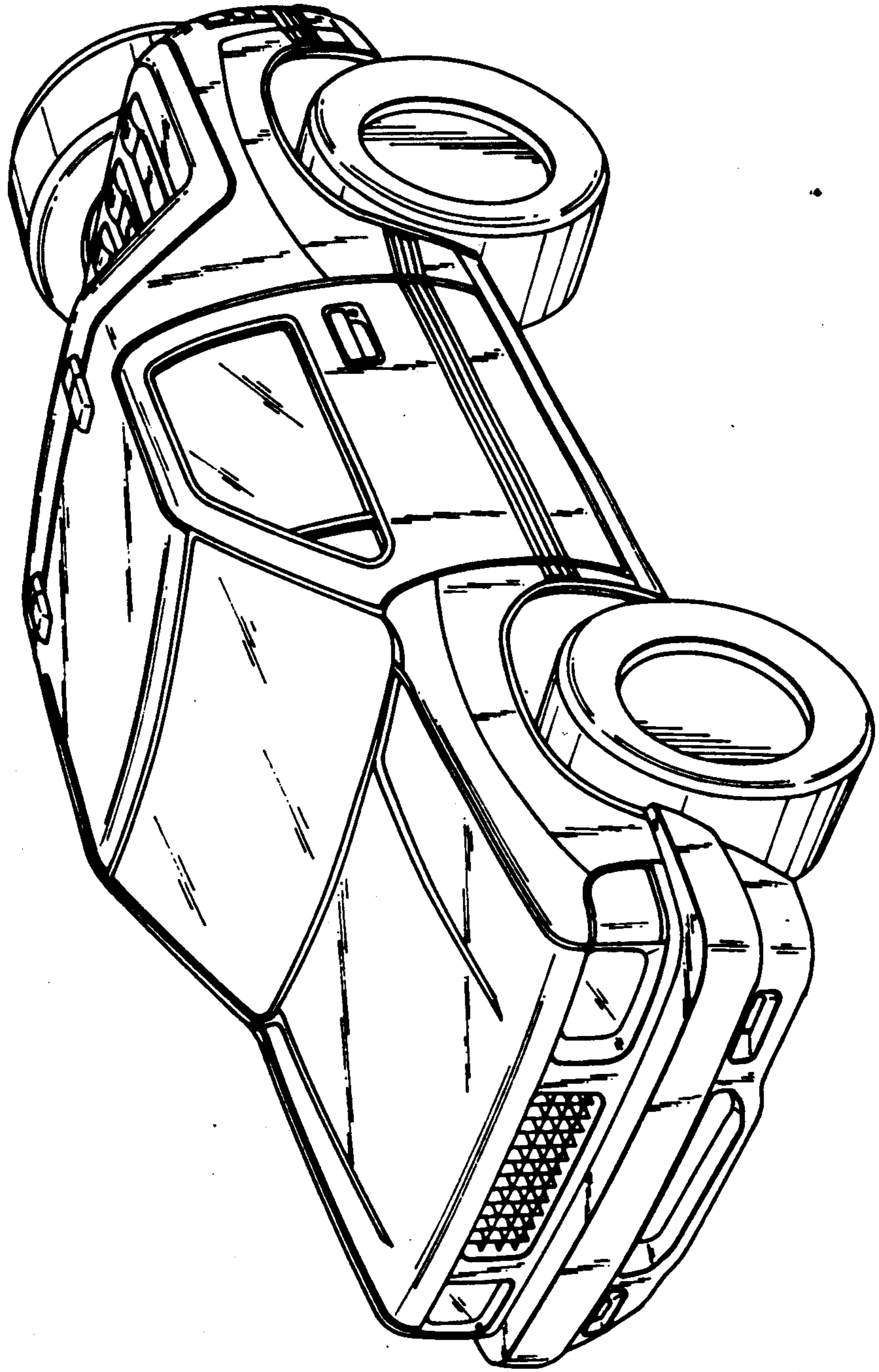

FIG. 2

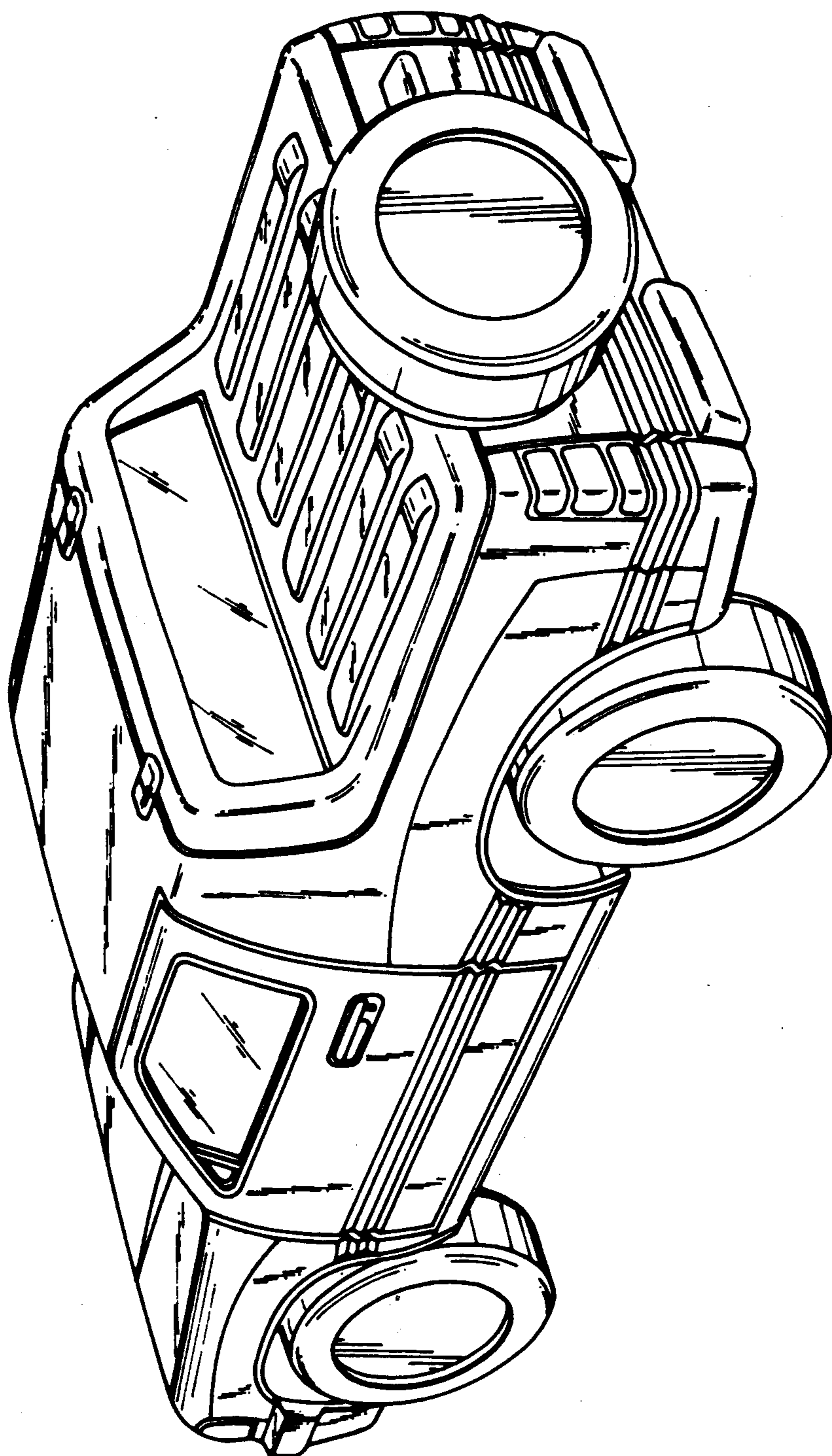

FIG. 3

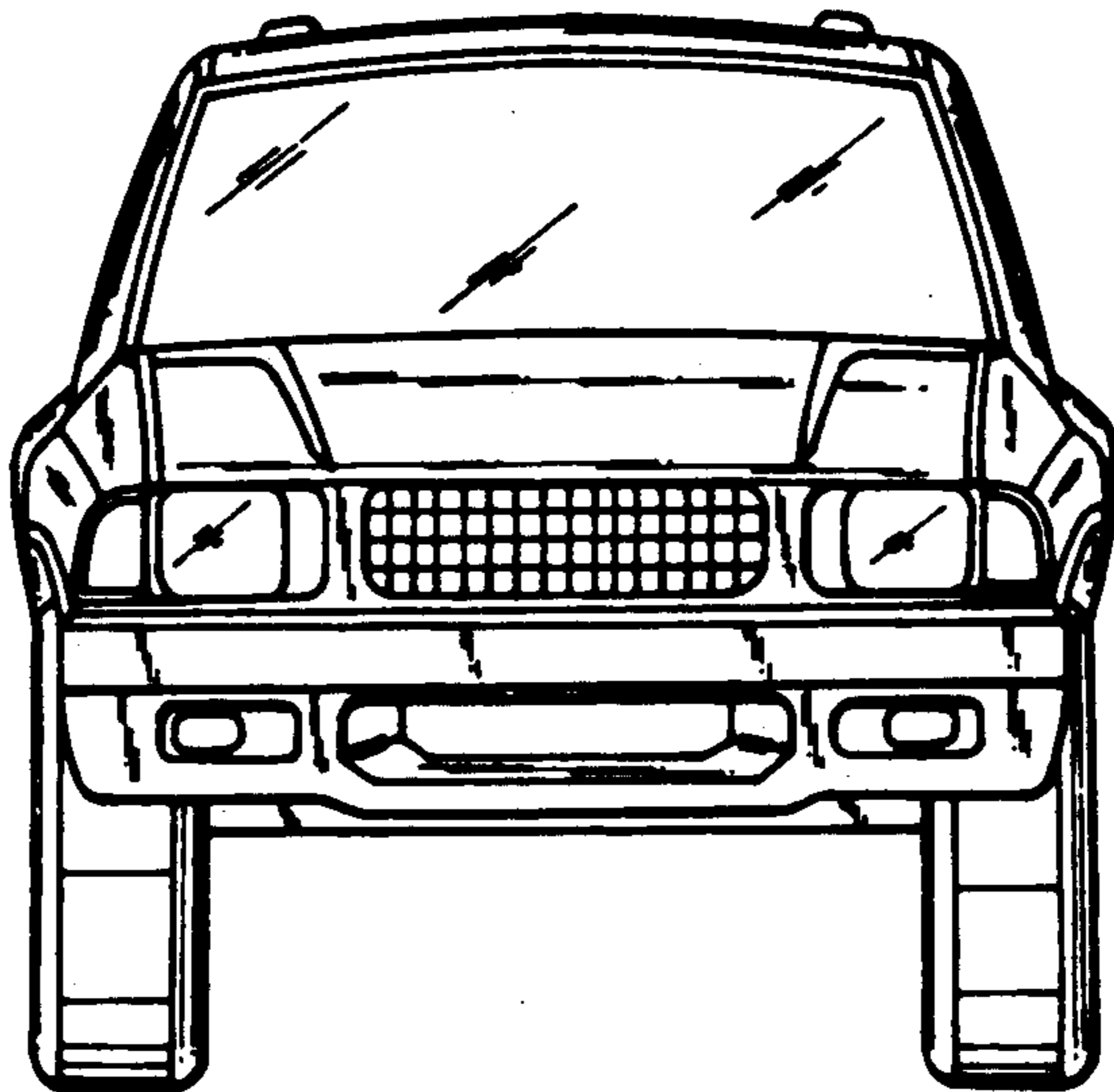

FIG. 4

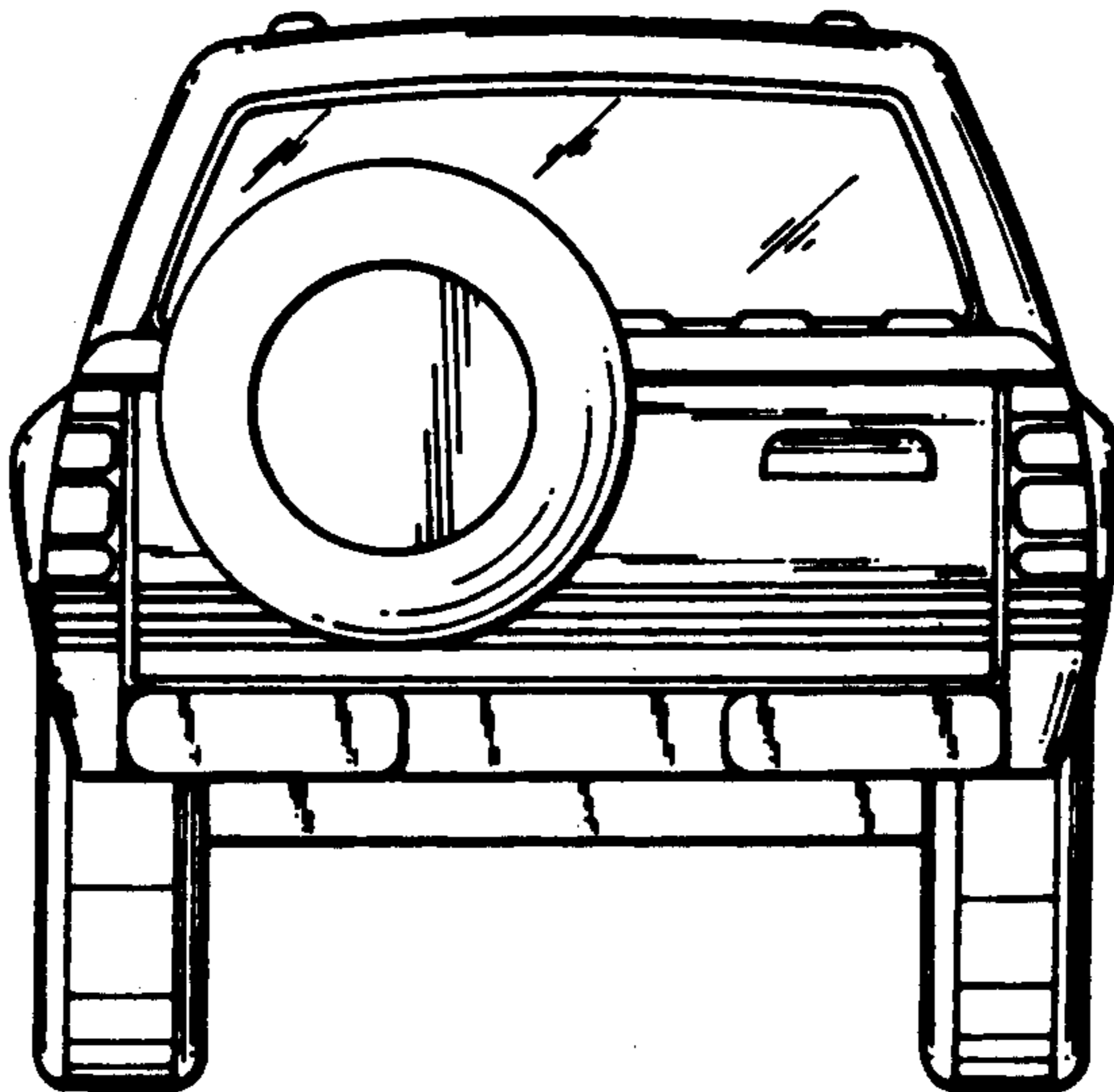

FIG. 5

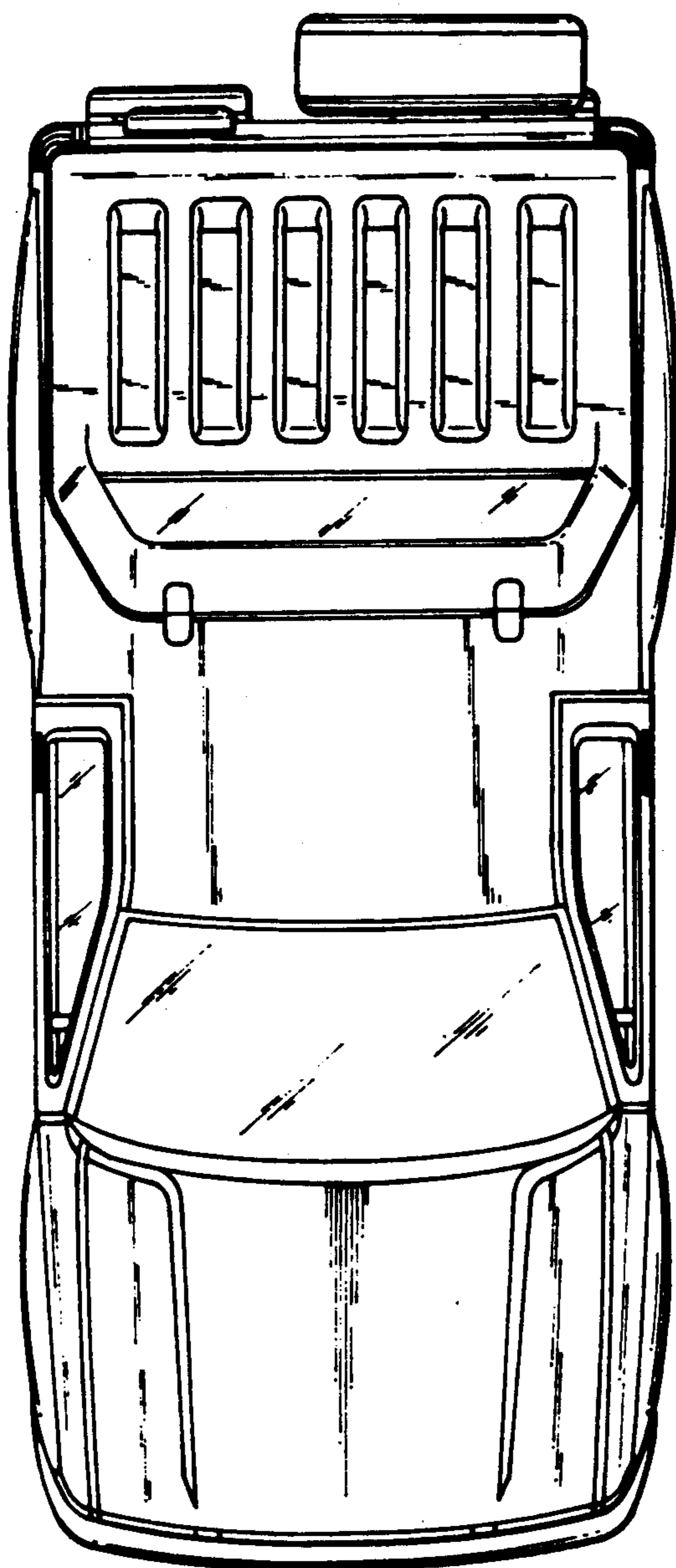

FIG. 6

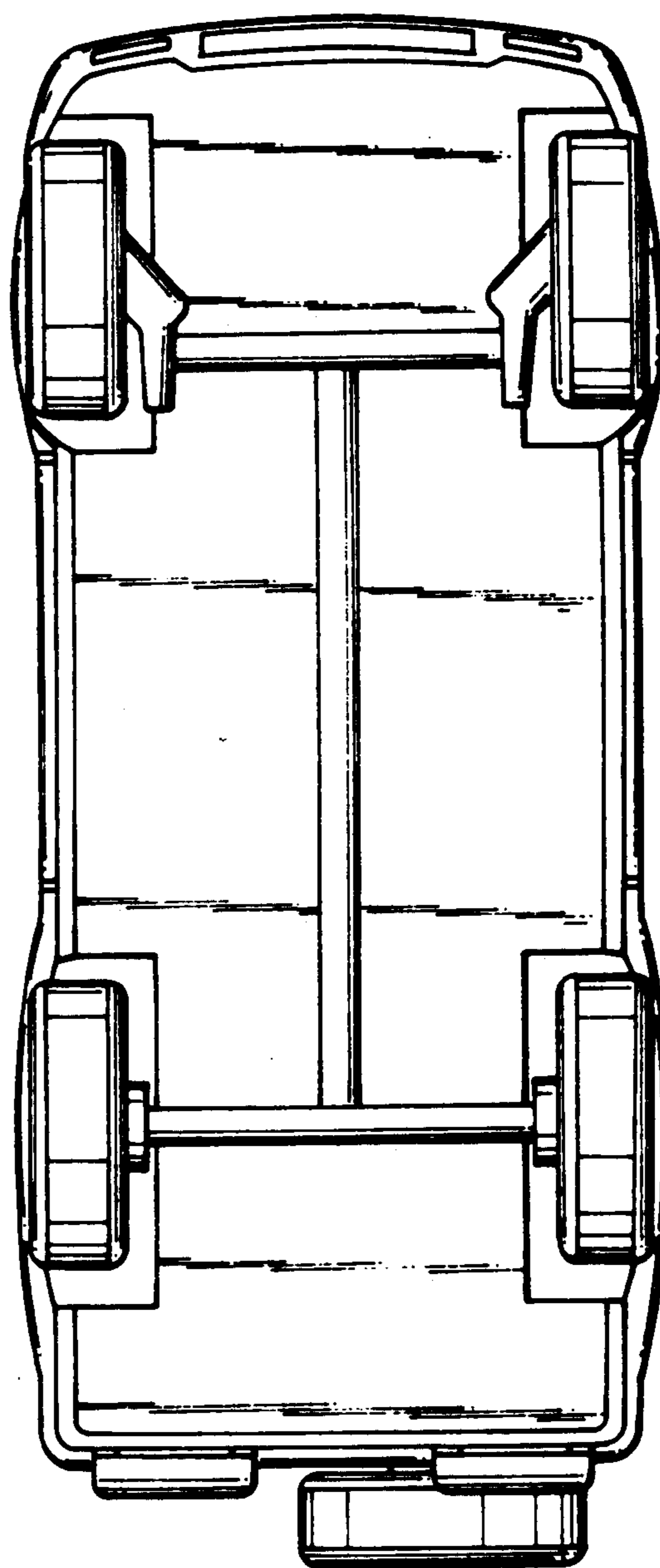

FIG. 7

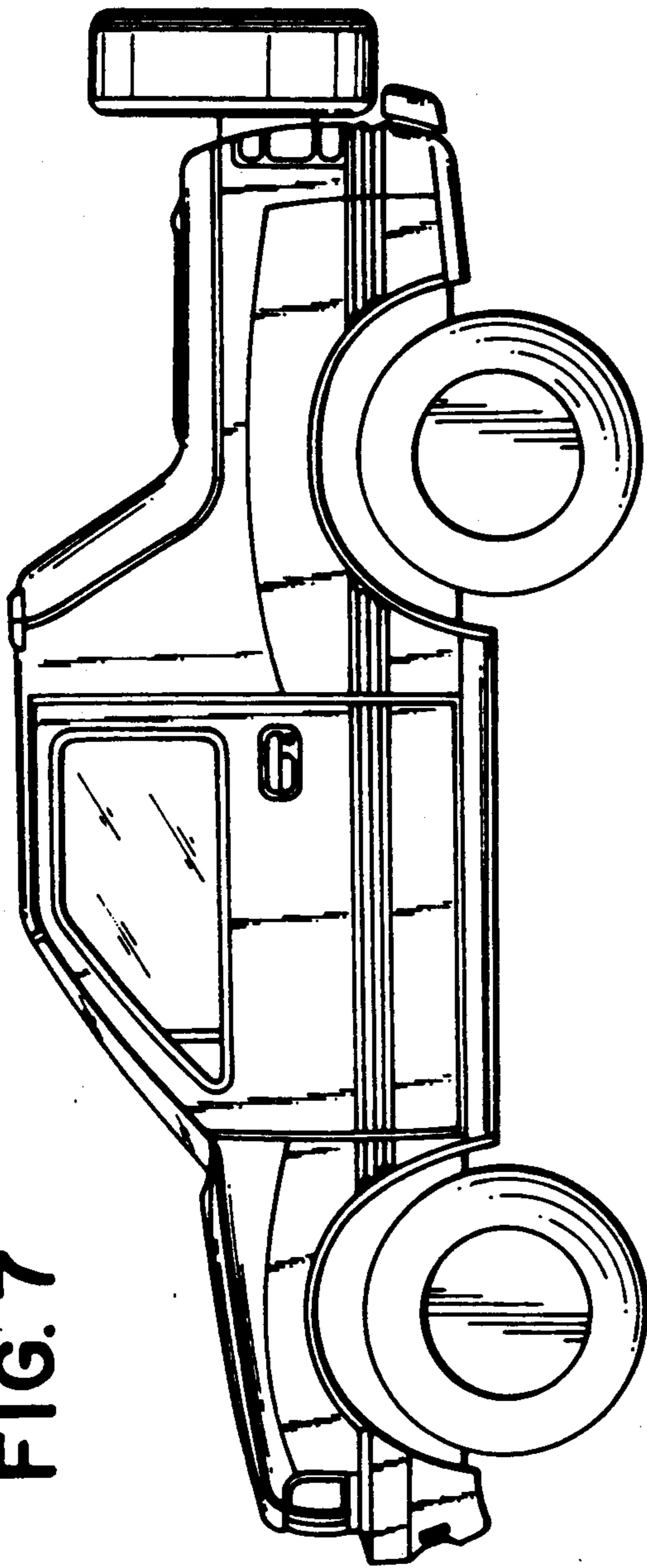

FIG. 8

