

[54] **GOLF SHOE CLEANING UNIT FOR ATTACHMENT TO A GOLF CAR**

[76] **Inventor: James J. Parchment, 5561 W. River, Banning, Calif. 92220**

[**] **Term: 14 Years**

[21] **Appl. No.: 307,979**

[22] **Filed: Feb. 9, 1989**

[52] **U.S. Cl. D12/16**

[58] **Field of Search D12/16, 203; 280/DIG. 6, 158, 164.2; 15/34, 105, 106, 160, 161**

[56] **References Cited**

U.S. PATENT DOCUMENTS

98,750	1/1870	Duly	280/164.2
1,212,111	1/1917	Roos	280/164.2
1,389,201	8/1921	Linville et al.	280/164.2
1,693,305	11/1928	Macdonald	280/164.2
2,692,144	10/1954	Wofford	280/164.2
2,818,594	1/1958	Dawkins	280/164.2
2,979,340	4/1961	Morrissey	280/164.2
3,028,617	4/1962	Racina	15/160
3,740,072	6/1973	Veith	280/164.2
3,747,150	7/1973	Kozub	15/105
4,425,677	1/1984	Cox	15/161
4,571,767	2/1986	Dangler	15/161
4,673,082	6/1987	Hemme	280/DIG. 6

FOREIGN PATENT DOCUMENTS

0524955	5/1956	Canada	280/164.2
2721605	11/1978	Fed. Rep. of Germany ...	280/164.2
0315158	7/1929	United Kingdom	280/164.2

Primary Examiner—James M. Gandy
Assistant Examiner—Melody N. Brown
Attorney, Agent, or Firm—Kelly, Bauersfeld & Lowry

[57] **CLAIM**

The ornamental design for a golf shoe cleaning unit for attachment to a golf car, as shown.

DESCRIPTION

FIG. 1 is a perspective view of a golf shoe cleaning unit for attachment to a golf car showing my new design, it being understood that the broken lines are for illustrative purposes only and form no part of the claimed design;

FIG. 2 is an enlarged perspective view thereof;

FIG. 3 is an enlarged perspective view thereof in open condition;

FIG. 4 is an enlarged front elevational view thereof;

FIG. 5 is an enlarged left side elevational view thereof, the right side elevational view being a mirror image thereof;

FIG. 6 is an enlarged rear elevational view thereof.

FIG. 7 is an enlarged top plan view thereof; and

FIG. 8 is an enlarged bottom plan view thereof.

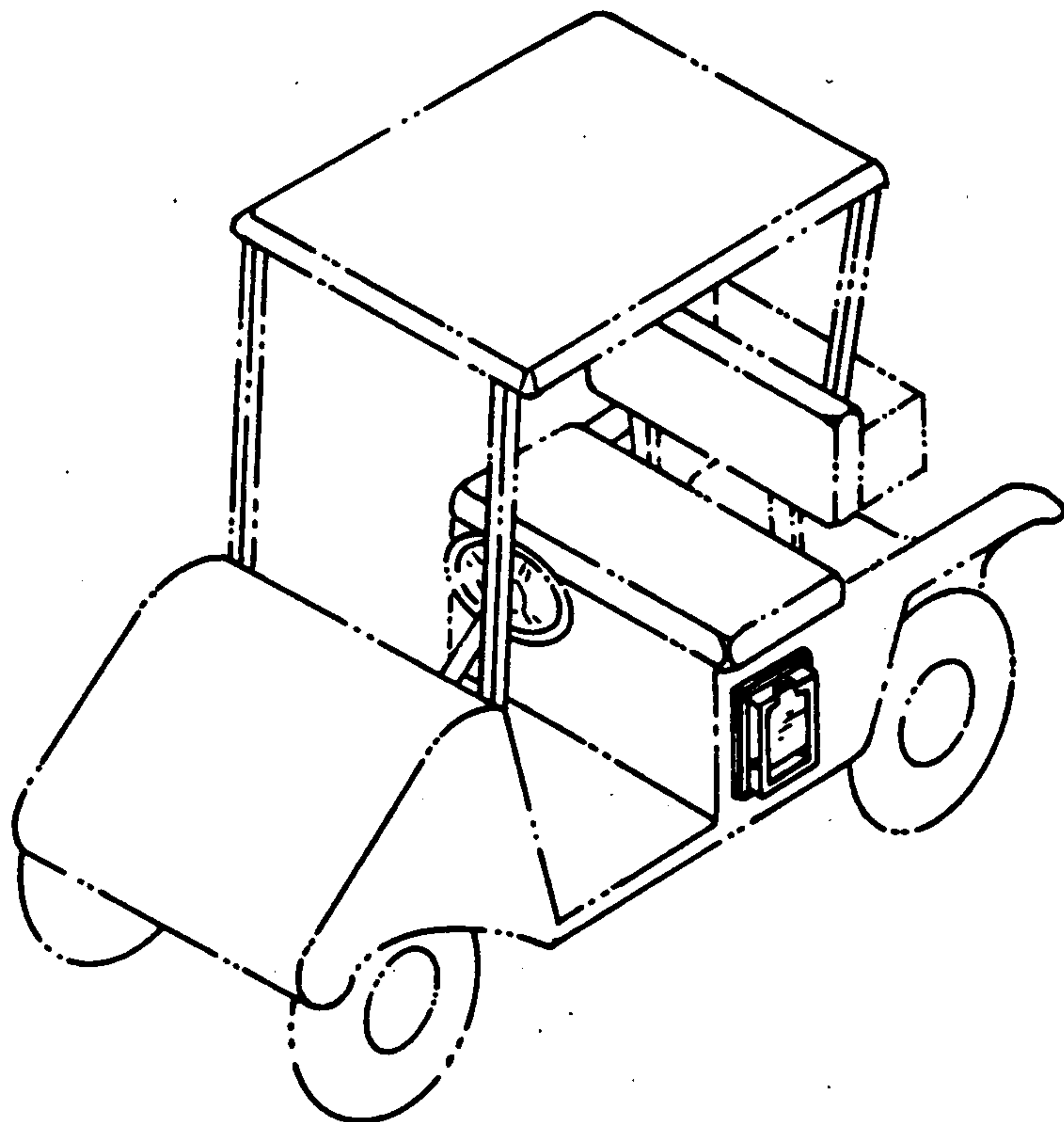

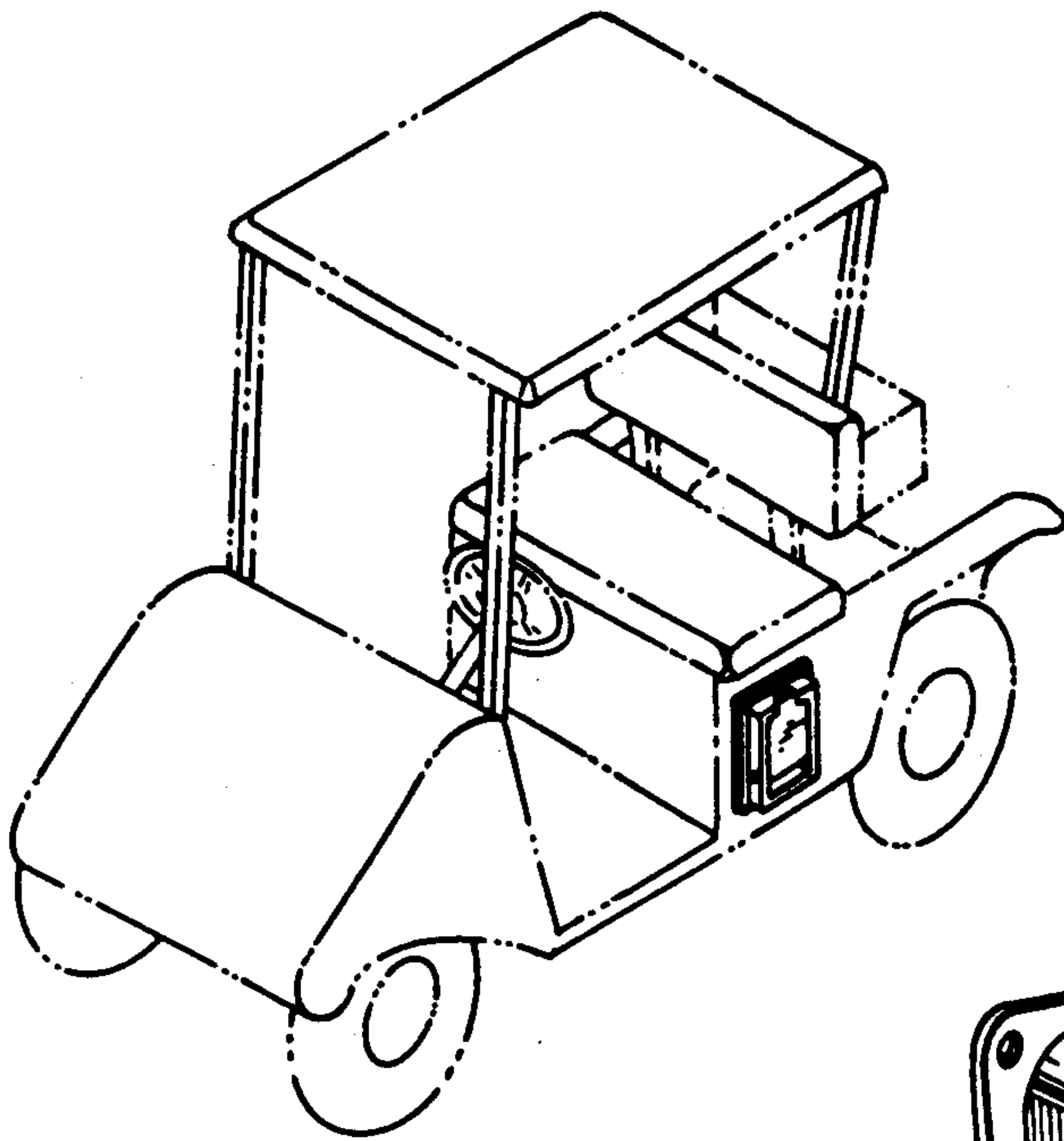

FIG. 1

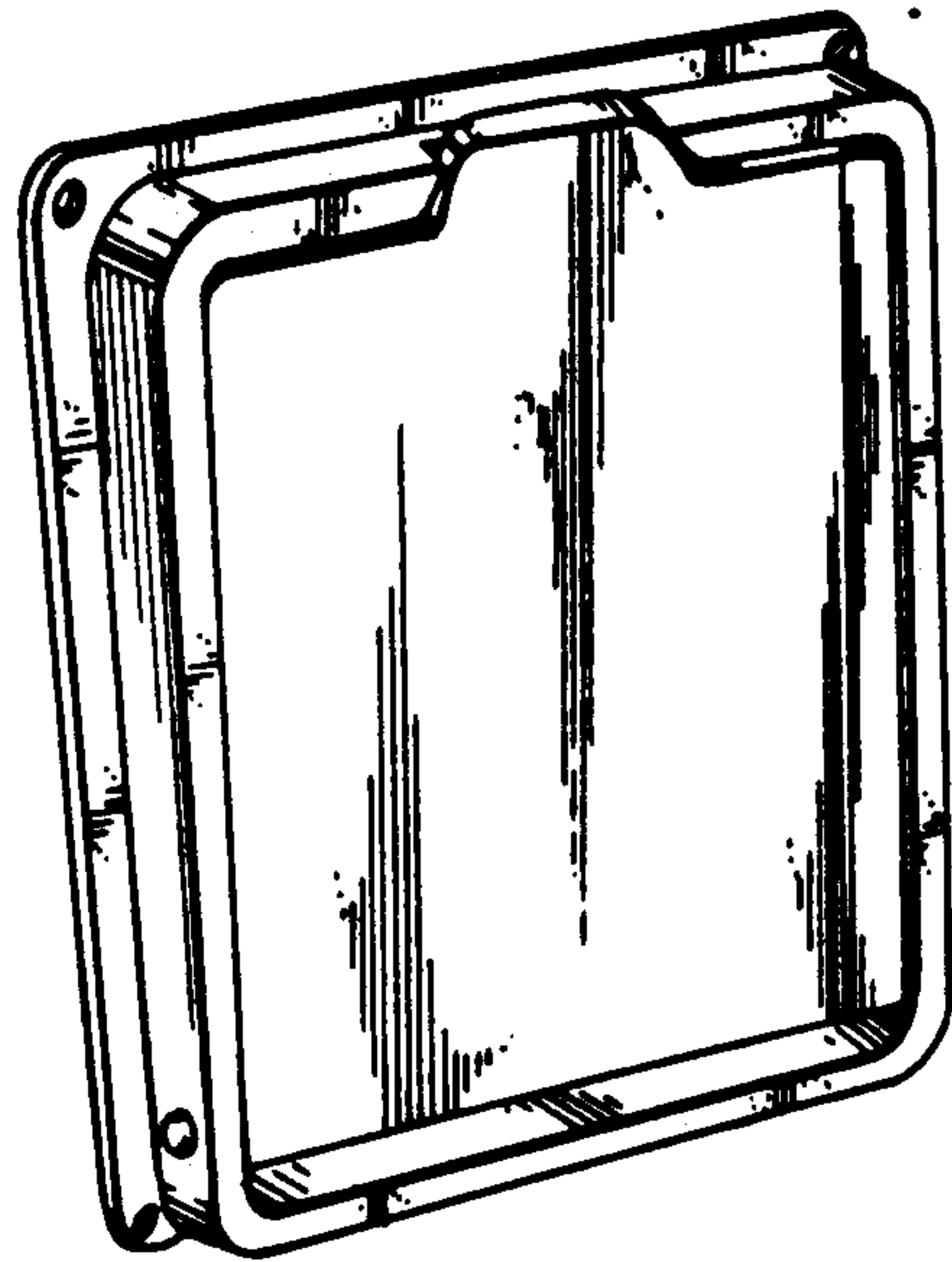

FIG. 2

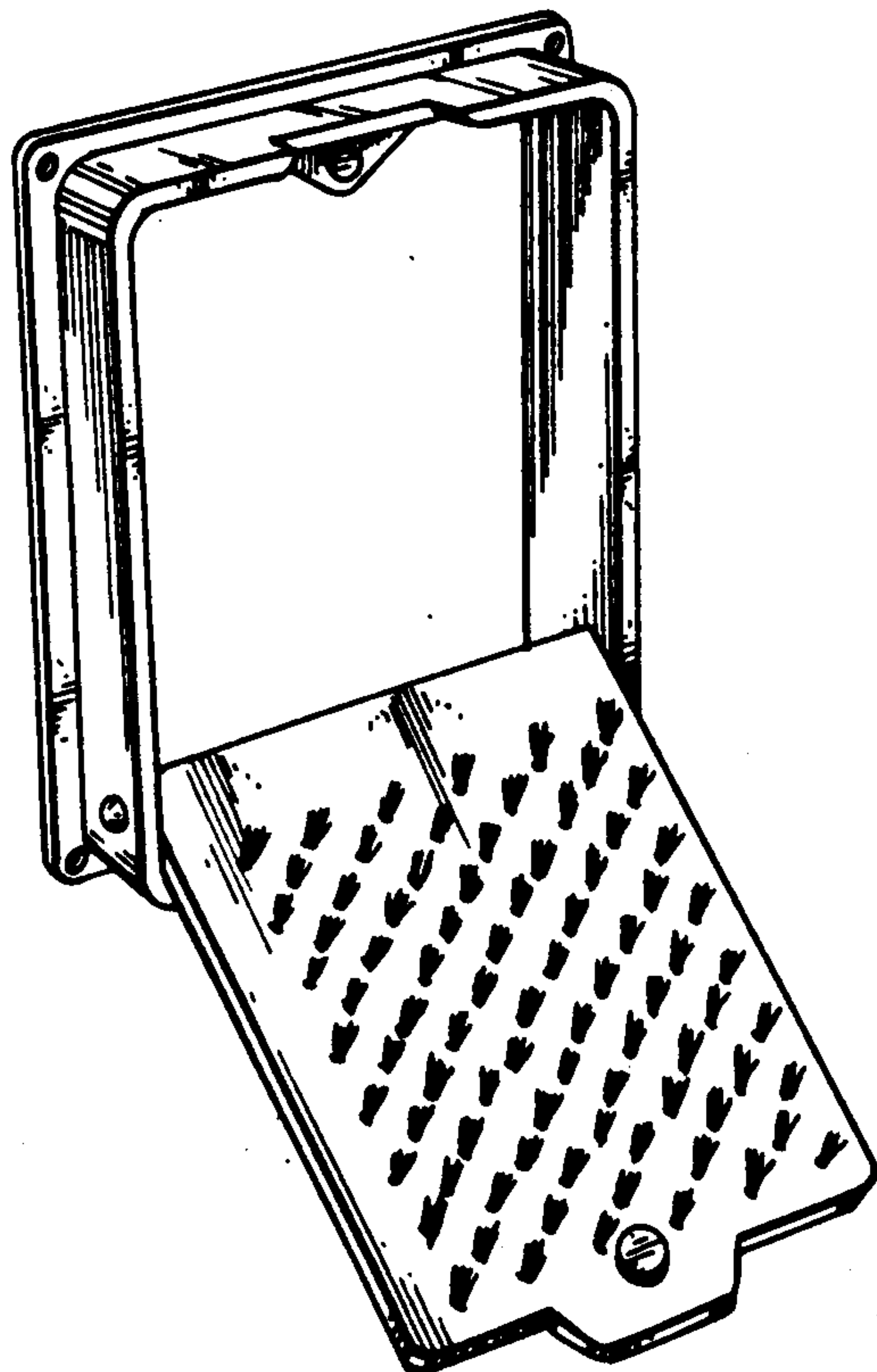

FIG. 3

FIG. 4

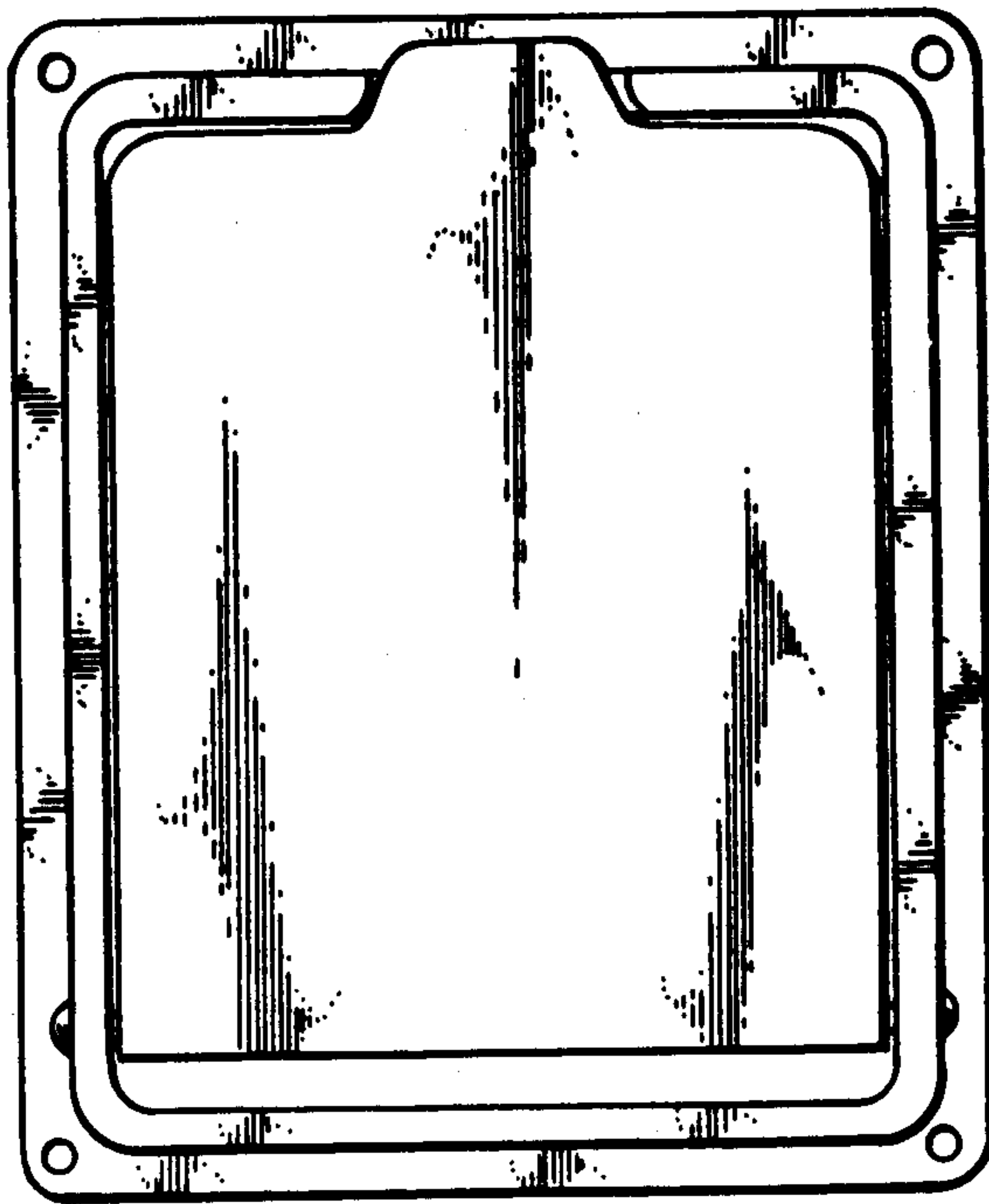

FIG. 5



FIG. 6

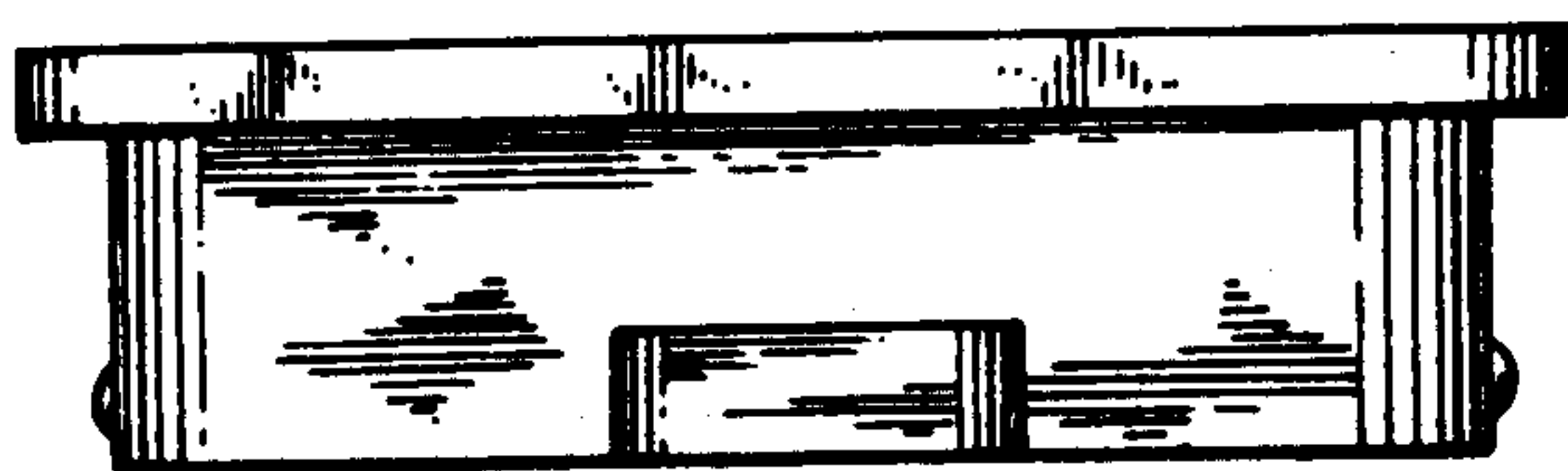
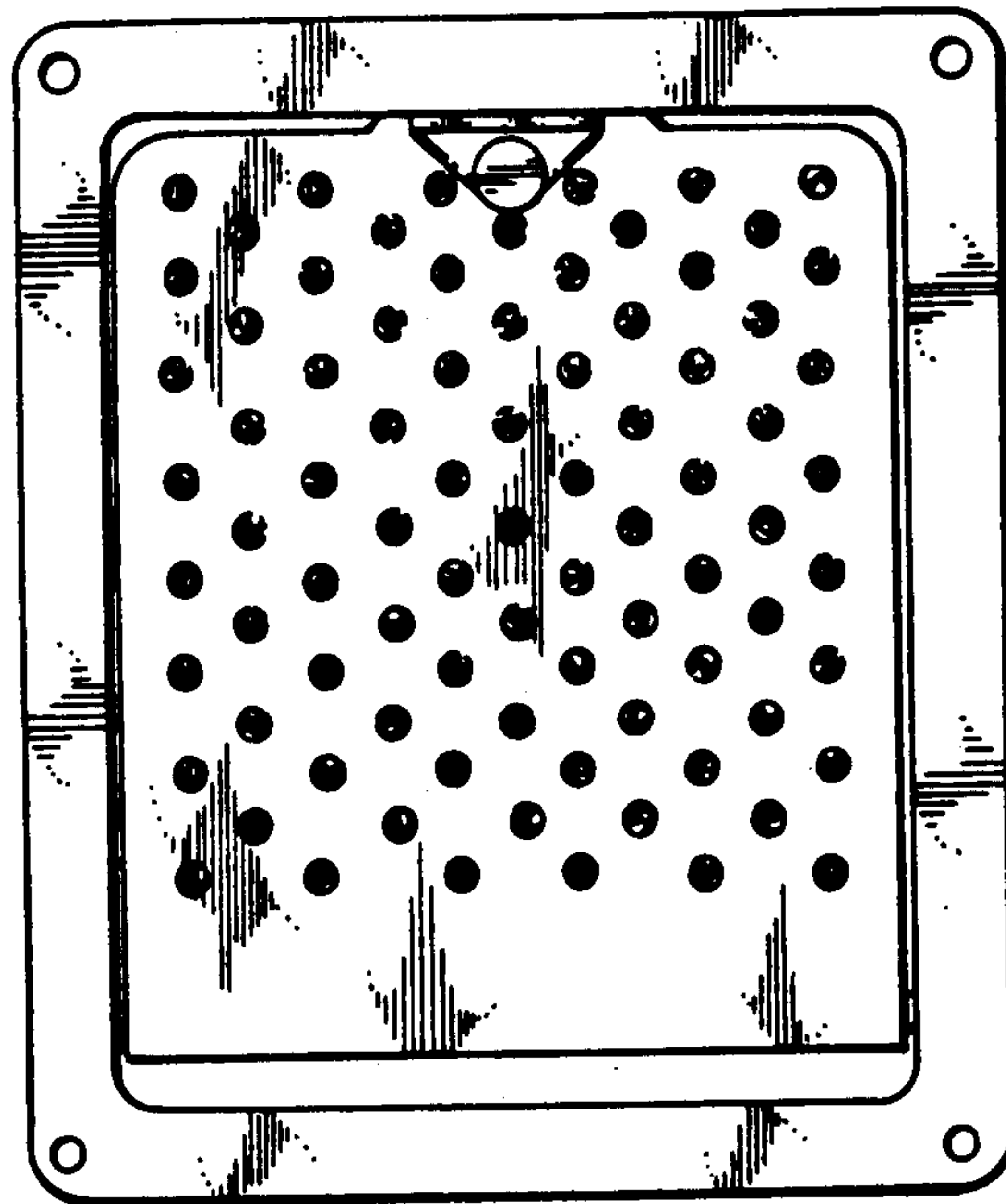

FIG. 7

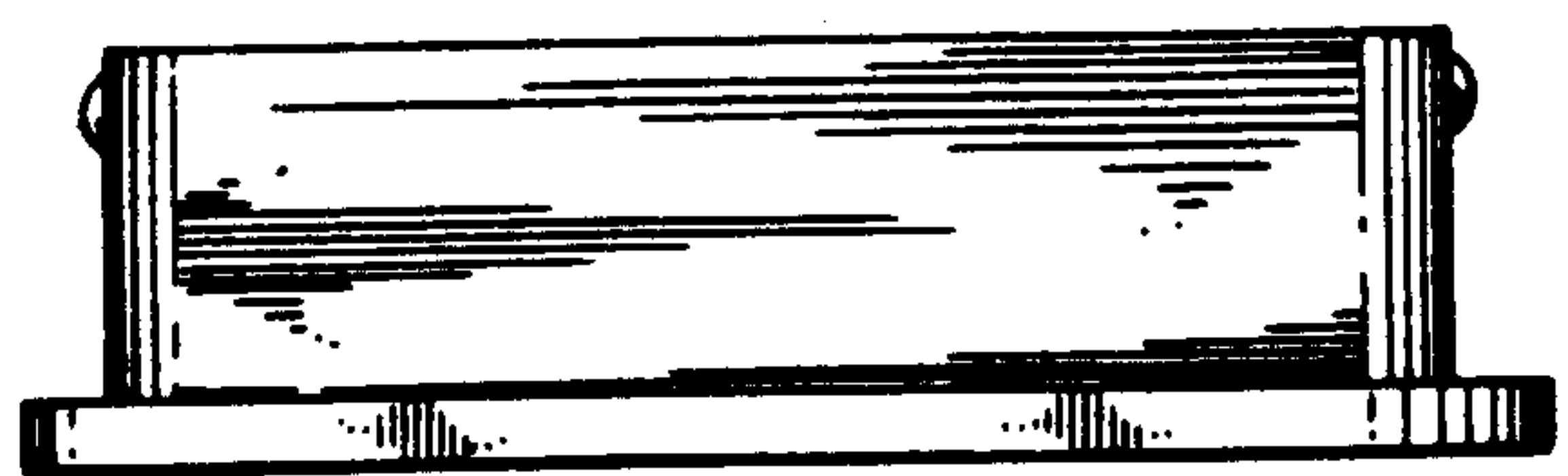

FIG. 8