

[54] LAMP BASE

[75] Inventors: Leslie A. Meck, Blandon; Peter Pettersson, Bernville, both of Pa.

[73] Assignee: Baldwin Hardware Corporation, Reading, Pa.

[**] Term: 14 Years

[21] Appl. No.: 387,312

[22] Filed: Jul. 31, 1989

[52] U.S. Cl. D26/142; D26/109

[58] Field of Search D26/93, 102-112, D26/142, 149, 151; 362/410-414

[56] References Cited

U.S. PATENT DOCUMENTS

D. 82,693 12/1930 Peters D26/109

OTHER PUBLICATIONS

Dunning Industries Lamp Catalog, 1973, p. 48, "Steins" Table Lamp Base.

Interiors, 10-173, p. 132, Mutual-Sunset Table Lamp.

Primary Examiner—Susan J. Lucas
Attorney, Agent, or Firm—Myron B. Kapustij; Edgar A. Zarins; Malcolm L. Sutherland

[57] CLAIM

The ornamental design for a lamp base, as shown and described.

DESCRIPTION

FIG. 1 is a perspective view of a lamp base showing our new design;

FIG. 2 is a top plan view thereof on an enlarged scale; FIG. 3 is a front elevational view thereof on an enlarged scale, the rear being identical;

FIG. 4 is a side elevational view thereof on an enlarged scale, the opposite side being identical.

The broken line representation of a lamp shade and lamp poles are for illustrative purposes only.

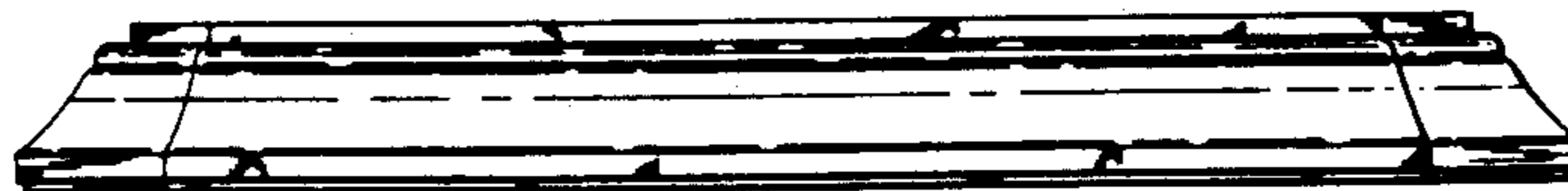
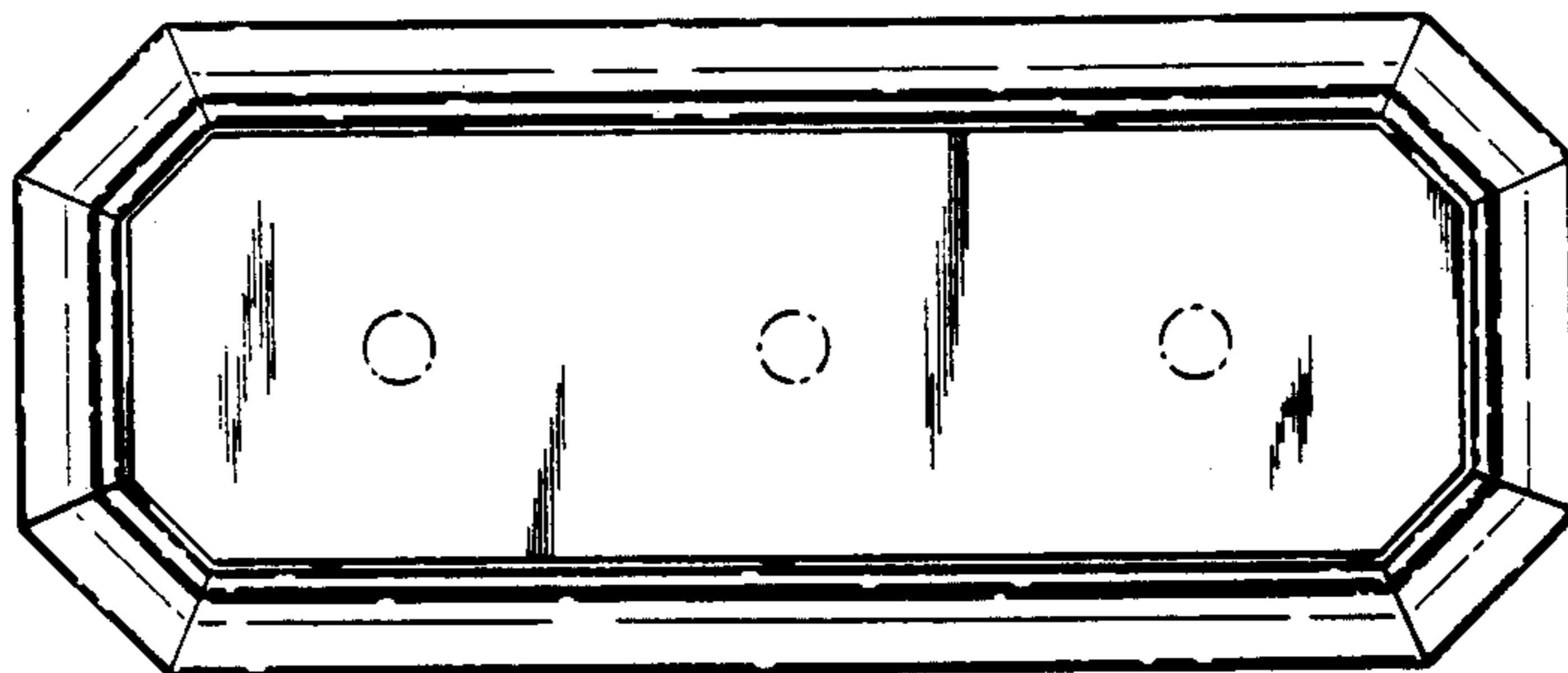
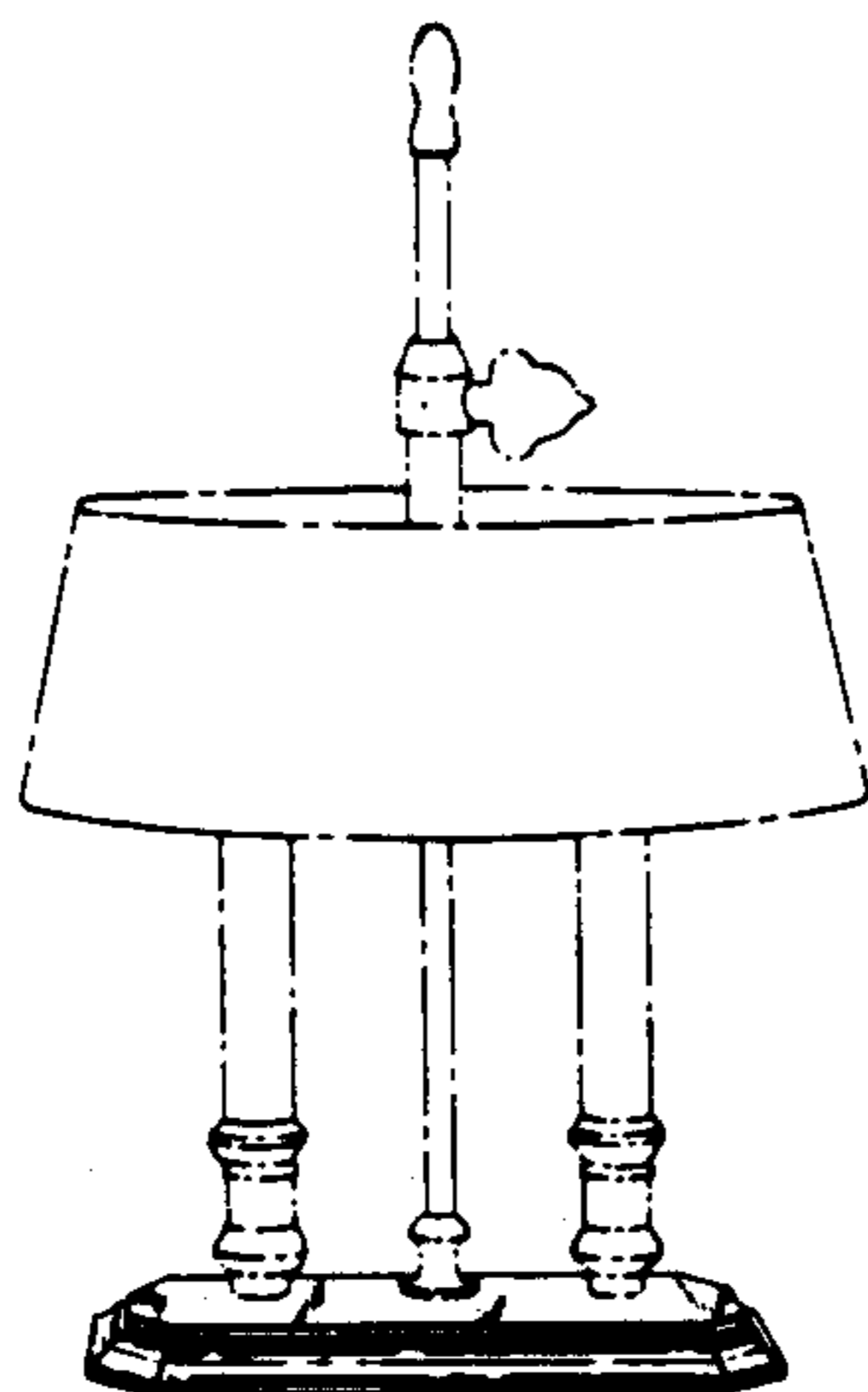

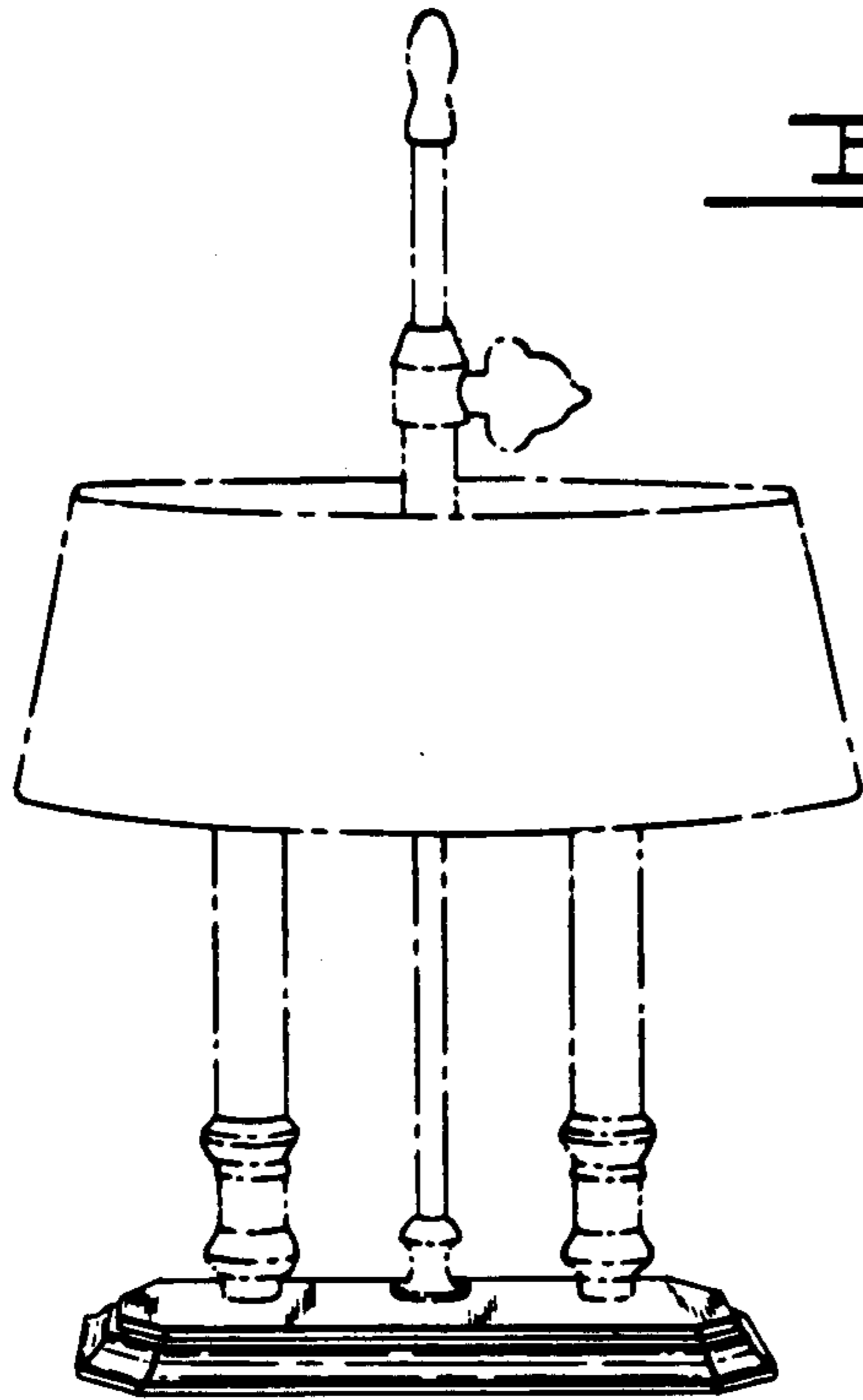

FIG. 1.

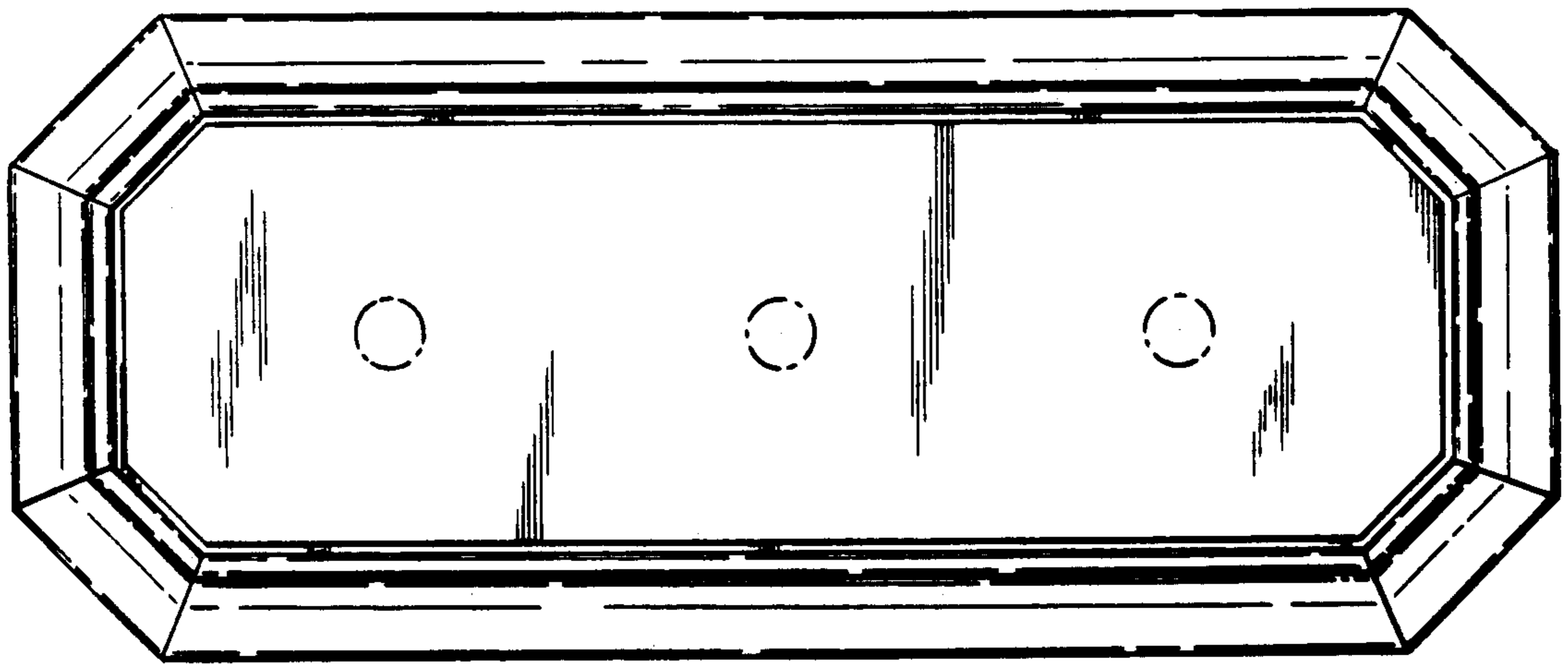

FIG. 2.

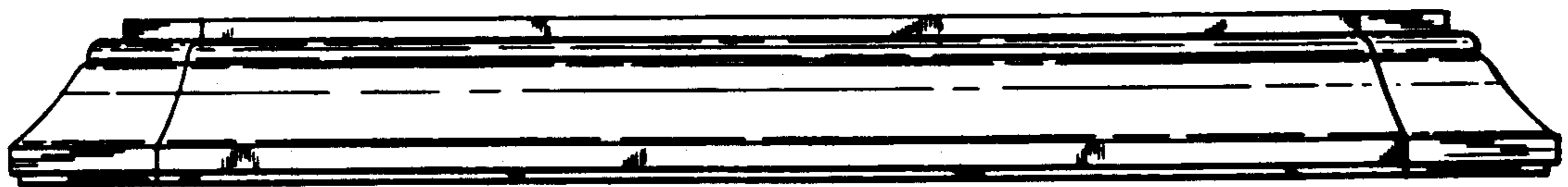

FIG. 3.

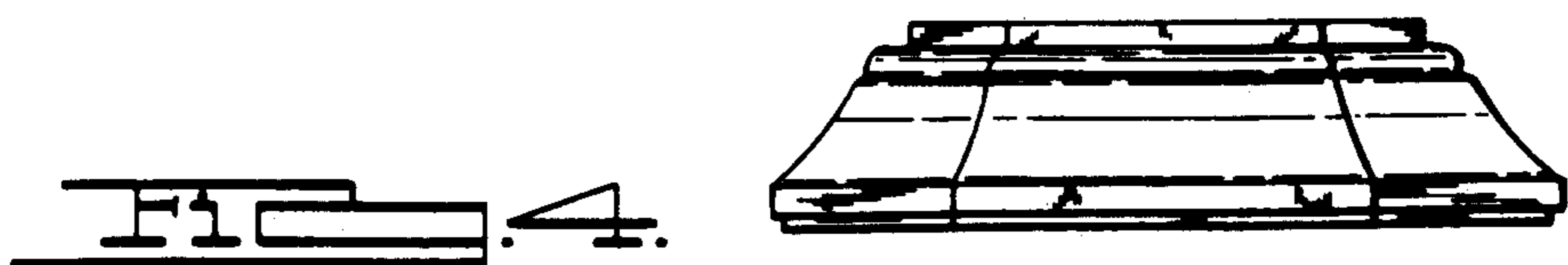

FIG. 4.